

*Ron McAllen*

S229-7037-3

**IBM** Maintenance  
Handbook

**IBM 3270 Information  
Display System**

**IBM 3271 Control Unit**

**IBM 3272 Control Unit**

**IBM 3275 Display Station**

**IBM 3277 Display Station**

**IBM 3284 Printer**

**IBM 3286 Printer**

**IBM 3288 Line Printer**



S229-7037-3



## **Maintenance Handbook**

**IBM 3270 Information  
Display System**

**IBM 3271 Control Unit**

**IBM 3272 Control Unit**

**IBM 3275 Display Station**

**IBM 3277 Display Station**

**IBM 3284 Printer**

**IBM 3286 Printer**

**IBM 3288 Line Printer**

## Preface

This handbook brings together reference and unique maintenance information that is pertinent to the maintenance of the 3270 Information Display System. For the purposes of this handbook, the IBM 3270 Information Display System is considered to consist of only the following units:

- IBM 3271 Control Unit
- IBM 3272 Control Unit
- IBM 3275 Display Station
- IBM 3277 Display Station
- IBM 3284 Printer
- IBM 3286 Printer
- IBM 3288 Line Printer

This publication does not replace existing MLTGs, but does provide the following quick reference material:

- 3270 Card Caddy Lists
- 3270 Symptom Fix Lists
- 3270 Block Diagrams
- 3270 Gate Card Layouts
- 3270 Card Substitution Lists
- 3270 Service Aids

This handbook contains eight sections and two appendixes. Each section has its own contents table.

### Fourth Edition (May 1978)

This is a major revision of, and obsoletes, S229-7037-2, with changes in all sections. Sections 6 and 7 have been considerably changed. Information in this publication is subject to change. Any such change will be reported in subsequent revisions or Technical Newsletters.

A form is provided at the back of this publication for readers' comments. If the form has been removed, comments may be addressed to IBM Corporation, Department R20, Neighborhood Road, Kingston, N.Y. 12401.

©Copyright International Business Machines Corporation 1975, 1976, 1977, 1978

## Contents

Section 1.	General Reference . . . . .	1
Section 2.	3271 Control Unit . . . . .	2
Section 3.	3272 Control Unit . . . . .	3
Section 4.	3275 Display Station . . . . .	4
Section 5.	3277 Display Station . . . . .	5
Section 6.	3284/3286 Printer . . . . .	6
Section 7.	3288 Line Printer . . . . .	7
Section 8.	Synchronous Data Link Control (SDLC) . . . . .	8
Appendix A.	3270 System Publications . . . . .	A
Appendix B.	3270 Tools and Test Equipment . . . . .	B
Index	. . . . .	X



## Section 1. General Reference

### Contents

1

<b>3270 Control Unit to Device Interface</b> . . . . .	1-3
<b>3270 Control Unit to Device Interface for RPQ AB4820</b> . . . . .	1-4
<b>Coaxial Cables and BNC Connectors</b> . . . . .	1-5
<b>Power Supply Ripple</b> . . . . .	1-5
<b>Logic Levels — 3270 VTL</b> . . . . .	1-6
<b>Missing Grounds</b> . . . . .	1-7
<b>Ground Loops</b> . . . . .	1-7
<b>3270 Recommended Card Caddy Lists</b> . . . . .	1-9
<b>Facilities Error Recognition System (FERS)</b> . . . . .	1-14
<b>3270 Service Aids</b> . . . . .	1-15
3270 Coax Cable Check . . . . .	1-15
AMP Tool . . . . .	1-17
Power Supply Mounting . . . . .	1-17
Card Swapping . . . . .	1-17
Logic Manual IR Pack and MLTG Storage . . . . .	1-17
3270 Card Holder Part Numbers . . . . .	1-17
Test Request Function for 3270s Using BTAM . . . . .	1-17
Individual LED Replacement . . . . .	1-20
CE General Logic Probe Use on 3270 . . . . .	1-20
<b>Control Unit Sequence Latches and Tables of Sequences</b> . . . . .	1-21
Sequence Latches . . . . .	1-21
Table of Sequences . . . . .	1-21
<b>Scoping Procedure to Determine Device Condition</b> . . . . .	1-25
<b>Display or Printer Status Word Detected on 3271 CU</b> . . . . .	1-26
<b>Display or Printer Status Word Detected on 3272 CU</b> . . . . .	1-27
<b>CU CW1 Detected on 3277 Device</b> . . . . .	1-27
3277 Connected to 3271 CU . . . . .	1-27
3277 Connected to 3272 CU . . . . .	1-28
<b>CU CW1 Detected on Printer 3284/3286/3288</b> . . . . .	1-28
3284/3286 Connected to 3271 CU . . . . .	1-28
3284/3286 Connected to 3272 CU . . . . .	1-29
Visual Verification of Correct AID Encoding . . . . .	1-31
Status Word and CU CW1 Scoping Points on Unique 3270 Box . . . . .	1-31
CU Data Words . . . . .	1-33
CU Control Words . . . . .	1-33
Message Buffer Bit Assignment . . . . .	1-35
Character Code Assignments . . . . .	1-36
<b>3270 Commands</b> . . . . .	1-43
<b>3270 Commands, AIDs, CCs, Orders, Addressing, and Status and Sense</b> . . . . .	1-44
<b>Indicators and Controls</b> . . . . .	1-67
<b>Sequences and Responses</b> . . . . .	1-70
<b>IR Functional Unit Code Guide</b> . . . . .	1-87
3271/3272/3275/3277/3284/3286 . . . . .	1-87
3275 Model III Display Unit . . . . .	1-97
3288 Model II . . . . .	1-100

## Figures

Figure 1-1.	Power Supply Ripple . . . . .	1-6
Figure 1-2.	3270 System Grounding . . . . .	1-8
Figure 1-3.	Basic Card Caddy List (2 parts) . . . . .	1-9
Figure 1-4.	Feature and RPQ Card Caddy List (3 parts) . . . . .	1-11
Figure 1-5.	Waveforms of Various Cable Conditions . . . . .	1-16
Figure 1-6.	Attribute Character Bit Definition . . . . .	1-24
Figure 1-7.	Status Word Waveform . . . . .	1-29
Figure 1-8.	Display Status Word . . . . .	1-29
Figure 1-9.	Printer Status Word . . . . .	1-29
Figure 1-10.	Status/Control Word (3272) . . . . .	1-30
Figure 1-11.	Status/Control Word (3271) . . . . .	1-30
Figure 1-12.	Status Word Waveform . . . . .	1-30
Figure 1-13.	CU CW1 Detected on 3284/3286/3288 . . . . .	1-30
Figure 1-14.	CU CW1 Detected on 3277 . . . . .	1-30
Figure 1-15.	CU Data Word Formats . . . . .	1-33
Figure 1-16.	CU Control Word Formats . . . . .	1-33
Figure 1-17.	Device Buffer Transfer (Data Words) to CU . . . . .	1-35
Figure 1-18.	Status Word Sent by Device . . . . .	1-36
Figure 1-19.	United States I/O Interface Code – EBCDIC . . . . .	1-37
Figure 1-20.	United States I/O Interface Code – ASCII . . . . .	1-38
Figure 1-21.	Variant of EBCDIC for Text Print Feature . . . . .	1-39
Figure 1-22.	3288 Text Print Feature Restricted Character Set (Copy Command) . . . . .	1-39
Figure 1-23.	Data Analysis – APL Feature Character Interchange Codes (2 parts) . . . . .	1-40
Figure 1-24.	Assignments for Internal 6-Bit Structured Data . . . . .	1-42
Figure 1-25.	Local and Remote Command Codes . . . . .	1-43
Figure 1-26.	Attention ID (AID) Configurations . . . . .	1-45
Figure 1-27.	Write Control Character (WCC) . . . . .	1-46
Figure 1-28.	Copy Control Character (CCC) . . . . .	1-47
Figure 1-29.	Sense Bit Description . . . . .	1-48
Figure 1-30.	Buffer Control Orders and Order Codes . . . . .	1-49
Figure 1-31.	3272 and Device Addressing – 16 or Fewer Devices per 3272 . . . . .	1-50
Figure 1-32.	3272 and Device Addressing – 17 or More Devices per 3272 . . . . .	1-50
Figure 1-33.	Status Byte Bit Assignments . . . . .	1-51
Figure 1-34.	Initial Status and Sense Conditions – Local . . . . .	1-52
Figure 1-35.	Ending Status and Sense Conditions – Local (2 parts) . . . . .	1-53
Figure 1-36.	Asynchronous Status and Sense Conditions – Local (3 parts) . . . . .	1-55
Figure 1-37.	Remote Control Unit and Device Addressing (3 parts) . . . . .	1-58
Figure 1-38.	Remote Status and Sense Byte Definitions (2 parts) . . . . .	1-61
Figure 1-39.	Remote Error Status and Sense Responses (4 parts) . . . . .	1-62
Figure 1-40.	Remote Status and Sense Conditions . . . . .	1-66
Figure 1-41.	Indicators and Controls . . . . .	1-68
Figure 1-42.	General Poll and Specific Poll, Sequence/Response Diagram (2 parts) . . . . .	1-70
Figure 1-43.	3270 CU Message Response to Polling or Read Modified Command (2 parts) . . . . .	1-72
Figure 1-44.	Selection Addressing, Sequence/Response Diagram (2 parts) . . . . .	1-74
Figure 1-45.	Write-Type and Control-Type Commands, Sequence/Response Diagram (2 parts) . . . . .	1-76
Figure 1-46.	Read-Type Command, Sequence/Response Diagram (2 parts) . . . . .	1-78
Figure 1-47.	3275-Initiated Transmission, Sequence/Response Diagram – Dial Feature (2 parts) . . . . .	1-80
Figure 1-48.	TCU-Initiated Transmission, Sequence/Response Diagram – Dial Feature (2 parts) . . . . .	1-82
Figure 1-49.	Example of Maintained Connection, Sequence/Response Diagram – Dial Feature (2 parts) . . . . .	1-84
Figure 1-50.	Status Message Transmission with Dial Feature, Sequence/Response Diagram . . . . .	1-86

## Section 1. General Reference

1

### 3270 CONTROL UNIT TO DEVICE INTERFACE

The 3270 Control Unit to device interface is a single wire type RG62AU coax, characteristic impedance 93 ohms, with serial-by-bit data transferred in either direction, but only one direction at a time. The control unit operates as the primary station and the attached device as a secondary station. Each device, attached directly to the control unit, receives and sends data addressed to that device only.

The following conditions for the coaxial cable must be observed:

1. DC and frame ground must be isolated (coaxial cable shield in dc return).
2. Thirteen cable splices are maximum (with compatible coaxial cable connectors). The outside of the connection is to be insulated by shrink fit tubing or equivalent to prevent accidental short to earth ground.
3. The inner conductor and outer shield of coaxial cable can be shorted without circuit damage at the control unit or device (Fault Condition).
4. A maximum of 20 ma of current can flow in the center conductor of the coaxial cable (Non-short condition) with power off at one end. This current will not trigger the control unit receiver.
5. Device power-up and down sequences must not introduce noise on the coaxial cable center conductor that might be interpreted as data (regardless of validity).
6. Shield currents on the coaxial cable will not cause more than  $\pm 20$  ns pulse width modulation.

Bits on the coaxial cable center conductor appear as negative-going pulses. The center conductor of the coaxial cable, when measured at the control unit with reference to the outer conductor (shield), will be +7.4 nominal (+1.1 - 2.2) volts with no signal present and power on at each unit. For maximum coaxial cable length (2000 feet or 610 m) the signal from the control unit on the coaxial cable center conductor will appear at the device as follows:

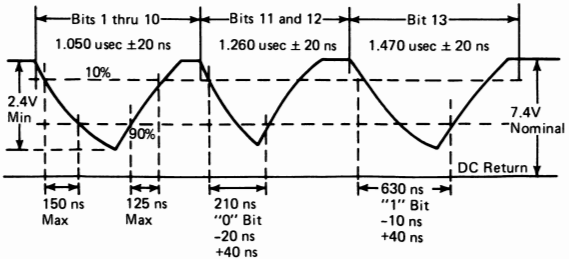

Bit timings from the device to the control unit will meet the same requirements as from control unit to device except for bit rate. The bit rate from the device will be 630 ns (min) to 1.050  $\mu\text{sec}$  (max) per bit. The minimum duration of the Up level, after crossing the 10% point going in the positive direction for a 1 or 0 bit until the start of the next consecutive bit, will be 30 ns.

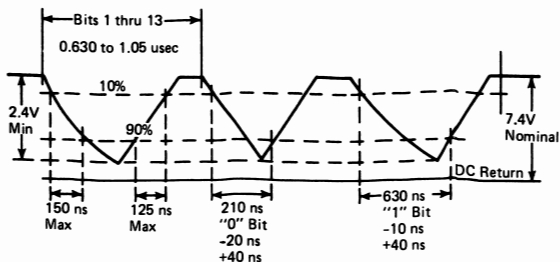

### 3270 CONTROL UNIT TO DEVICE INTERFACE FOR RPQ AB4820 (5000 FT OR 1 524 m)

Bits on the coaxial cable center conductor appear as negative-going pulses. The center conductor of the coaxial cable, when measured at the control unit with reference to the outer conductor (shield), will be 0 volts with no signal present and power on at each unit. The minimum cable length is 2000 feet (610 m). The maximum coaxial cable length is 5000 feet (1 524 m). The signal from the control unit on the coaxial cable center conductor will appear as follows at the device:

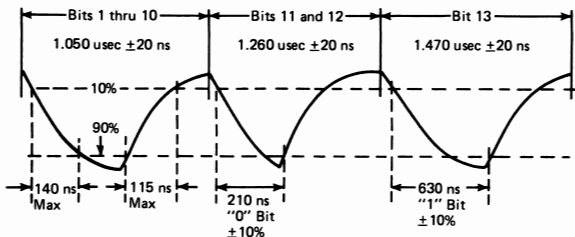

The pulse amplitude, as referenced to dc return (outer conductor of coaxial cable), will be as follows for a control unit or device:

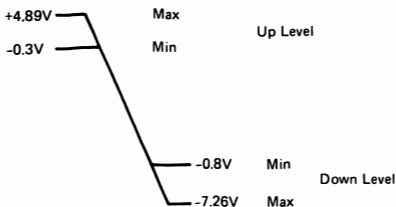

The minimum pulse amplitude at the receiving end is therefore 0.5V.

Bit timings from the device to the control unit will meet the same requirements as from control unit to device except for the bit rate. The bit rate from the device will be 630 ns minimum to 1.050 usec maximum per bit. The minimum duration of the "Up" level after crossing the 10% point going in the positive direction for a 1 or 0 bit until the start of the next consecutive bit will be 100 ns.

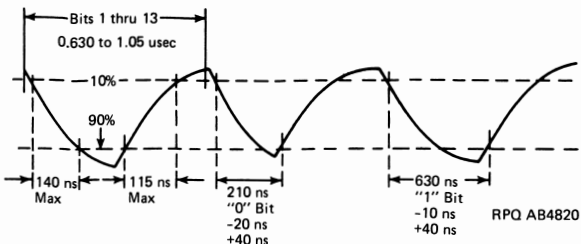

Up to 16 devices with greater than 2000-foot (610 m) capability may be attached to one control unit.

## COAXIAL CABLES AND BNC CONNECTORS

### Standard

- Coaxial cable (cable only) PN 323921 (RG 62 A/U)
- BNC (male) connector PN 5214874 (UG-260 B/U)
- BNC (female) adapter (extender) PN 5252643 (UG-914 U)
- Coax and BNCs (fitted) PN 2577672
- Kit of qty 2 BNC (male) connector B/M 1836418

### Underground

- Coaxial cable (cable only) PN 5252750
- BNC (male) connector PN 5252758
- BNC (female) adapter (extender) PN 5252764 (UG-492 A/U)
- Coax and BNCs (fitted) PN 1833108
- Kit of qty 2 BNC (male) connector B/M 1836419

## POWER SUPPLY RIPPLE

I/O errors, data checks, and various other problems which are intermittent and hard to define may be caused by excess ripple on the power supply voltages. Check all power supply capacitor screws for tightness. See Figure 1-1 for maximum ripple values.

<b>3271* and 3272</b> <b>DC Power Supply Voltage</b> +5V -12V +8V	<b>Maximum AC Ripple Voltage</b> 200 mv peak to peak 36 mv peak to peak 300 mv peak to peak
<b>3275*</b> <b>DC Power Supply Voltage</b> +5V -12V +8V +34V	<b>Maximum AC Ripple Voltage</b> 200 mv peak to peak 36 mv peak to peak 300 mv peak to peak 750 mv peak to peak
<b>3277</b> <b>DC Power Supply Voltage</b> +5V -12V +8V +34V	<b>Maximum AC Ripple Voltage</b> 200 mv peak to peak 10 mv peak to peak 300 mv peak to peak 750 mv peak to peak
<b>3284 and 3286</b> <b>DC Power Supply Voltage</b> +5V +24V -12V	<b>Maximum AC Ripple Voltage</b> 160 mv peak to peak 1V peak to peak 10 mv peak to peak
<b>3288</b> <b>DC Power Supply Voltage</b> +24V -12V +8.5V -5.0V +5.0V	<b>Maximum AC Ripple Voltage</b> 1V peak to peak 40 mv peak to peak 150 mv peak to peak 60 mv peak to peak 200 mv peak to peak

\*Ripple values shown are for Models 1 and 2. For Models 11 and 12 (SDLC), see Section 8.

**Figure 1-1. Power Supply Ripple**

## LOGIC LEVELS – 3270 VTL

The switching levels for the 3270 VTL logic are as follows:

Up (+) Level	+2.4 to +5.5V
Down (-) Level	0 to +0.4V
Floating Level	+1.0 to +2.0V

It is acceptable to "tie down" circuits to signal ground (D08). No signal should ever be "tied up" directly to a +5V pin (D03). There are specific "tie up" points shown in the FEALDS that allow signals to be tied up. Instead of using a "tie up" point, a 750- to 1000-ohm resistor can be attached in series with a D03 pin and the signal to be tied up. This will only tie up a floating level line. There is no way to tie up a line that is at a down level without damaging components.

## MISSING GROUNDS (Fig. 1-2)

### DANGER

A missing AC ground and leakage in the power supply of a unit will cause a shock hazard to exist.

## GROUND LOOPS (Fig. 1-2)

Ground loops can cause hard-to-define problems on a 3270 system. Some symptoms resulting from ground loops are:

1. Timeouts.
2. False status indications.
3. Hanging in transmit.
4. Data checks (with or without unit specify).
5. Equipment checks.
6. Intervention required.
7. Holding up request to send (3872).
8. Channel errors.
9. Hang conditions.
10. Control checks.
11. Extraneous device ends.

Signal ground and frame should be tied together only in the channel, external modem or modem cable. If these grounds are tied together at any other place, a ground loop condition can occur. The most common areas to find ground loops are in the keyboard (3277 ECA number 035 corrects this problem) and coaxial cable connections. Check for all ground loops while at the control unit by doing the following:

1. For control units (with the control unit not connected to a CPU or modem and all coaxial cables disconnected) the following resistance values should be measured between any D08 pin and frame ground.

Control Unit	Resistance
3271	Infinity (open circuit)
3272	Infinity (open circuit)
3275	7K to 10K ohms (minimum)

2. For devices, disconnect one coaxial cable at a time from the Control Unit and measure between the outer shield of the coaxial cable and frame ground of the control unit.

Device	Resistance
3277	7K to 10K ohms (min)
3284	Infinity (open circuit)
3286	Infinity (open circuit)
3288	Infinity (open circuit)

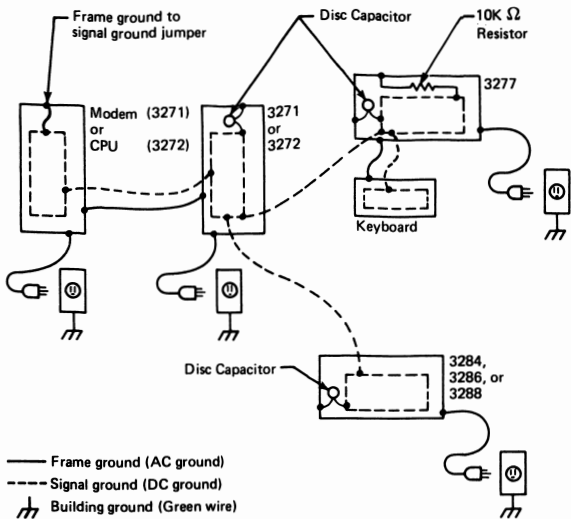

Figure 1-2. 3270 System Grounding

## 3270 RECOMMENDED CARD CADDY LISTS

Figures 1-3 and 1-4 list recommended part numbers for 3270 card caddies. The first list (Figure 1-3) contains part numbers that are found in the basic (EBCDIC/Leased Line) 3271, 3272, 3275, 3277, 3286, and 3288; the second list (Figure 1-4) contains part numbers for features and RPOs. These lists will be updated when part numbers of higher level cards become available. A current set of Group 39 CEMs and a 3277 Troubleshooting Guide should also be in the card caddy.

Card Part No.	Machine Type						
	3271	3272	3275	3277	3284	3286	3288
1815438							X
2568924			X	X			
2624104							X
2624112							X
5800036					X	X	
5863910							X
5864327							X
5864333					X	X	
8238903							X
8521492					X	X	X
8521494					X	X	
8521716	X	X					
8521717			X				
8521725	X	X					
8521731					X	X	X
8521732			X				
8521862			X	X			
8521863			X	X			
8521864	X		X				
8521967	X		X				
8521985	X	X			X	X	X
8522012					X	X	
8522105			X				
8522124	X	X					
8522139	X	X					
8522147	X	X					
8522149		X					
8522831	X	X					
8522836			X	X			
8522839	X						
8522858	X	X					
8523634	X	X					
8523635	X	X					
8523645	X		X				
8523648			X	X			

Figure 1-3 (Part 1 of 2). Basic Card Caddy List

Card Part No.	Machine Type						
	3271	3272	3275	3277	3284	3286	3288
8523659	X	X					
8523664				X			
8524282			X	X			
8524289			X	X			
8524302			X	X			
8524319	X	X					
8524587	X	X					
8524594			X				
8524596					X	X	X
8524604			X	X			
8526044					X	X	
8526055					X	X	
8526057	X	X					
8526058			X				
8526062	X	X					
8526064		X					
8526065							X
8526675							X
8526956					X	X	
8526969					X	X	
8526970		X					
8526971		X					
8527297		X					
8527302				X			
8527304	X	X					
8527906		X					
8527916	X		X				
8527981	X		X				
8527995							X
8528256	X		X				
8528262			X	X			
8528269			X				

Figure 1-3 (Part 2 of 2). Basic Card Caddy List

Card Part No.	Machine Type							Description
	3271	3272	3275	3277	3284	3286	3288	
5862859			X					Line Adapter w/o Auto Answer
5863763			X					Line Adapter w/o Auto Answer
5863955			X					Line Adapter with Auto Answer
5863960			X					3275-3 Bypass
5864334					X	X		Dual Case
8521499					X	X		ASCII A
8521500					X	X		ASCII B
8521501					X	X		Dual Case
8521505			X	X				Selector Pen
8521700					X	X		Dual Case
8521708			X	X				Dual Case
8521719			X					Dial All
8521824	X		X					1200 bps
8521846			X					Dial EBCDIC
8521968	X		X					Leased ASCII
8522131	X		X					4800/7200 bps
8522842			X					Dial EBCDIC
8522845	X							ASCII
8522846			X					Leased Line ASCII
8522849	X		X					Leased Line ASCII
8522853			X	X				2260 Compatibility
8522863			X					Dial ASCII
8522864			X					Dial EBCDIC
8522865			X					Dial ASCII
8522866			X					Dial ASCII
8522872			X	X				Tab to Colon
8523242				X				Signature Retrieval
8523257			X	X				Card Reader
8523625			X	X				2260 Compatibility
8523639			X	X				Tab to Colon
8523643					X	X		VFIC
8523646	X		X					Leased ASCII
8523653				X				5000 Ft RPQ
8523654					X	X		5000 Ft RPQ

Figure 1-4 (Part 1 of 3). Feature and RPQ Card Caddy List

Card Part No.	Machine Type							Description
	3271	3272	3275	3277	3284	3286	3288	
8523657			X					Print Key
8524284	X							Military Spec
8524285			X					Dial All
8524286			X					Dial EBCDIC
8524287			X					Dial ASCII
8524292				X				ASCII A
8524293				X				ASCII B
8524301				X				Dual Case
8524305				X				ASCII A
8524306				X				ASCII B
8524314			X	X				Dual Case
8524318	X	X						5000 Ft RPO
8524321	X	X						5000 Ft RPO
8524324			X					Dedicated Printer
8524586			X					Dial All
8524602			X					Print Key
8526000	X							3275-3
8526004	X							3275-3
8526046			X	X				2260 New Line
8526603				X				Signature Retrieval
8526604				X				Signature Retrieval
8526678			X					Dedicated Printer
8526681			X	X				7460-4 Card Reader
8526685	X		X					SDLC
8526691					X	X		APL
8526696	X	X						APL
8526960					X	X		APL
8526961					X	X		APL
8526965			X					3275-3
8526968				X				2956-8 Card Reader
8527026			X					3275 (9600 bps)
8527294	X	X						Lightning Protection
8527298			X					3275-3
8527300					X	X		APL
8527308				X				Double Zero/ Triple Zero
8527311	X		X					SDLC
8527897	X		X					SDLC (EBCDIC)

Figure 1-4 (Part 2 of 3). Feature and RPO Card Caddy List

Card Part No.	Machine Type							Description
	3271	3272	3275	3277	3284	3286	3288	
8527899	X		X					SDLC (ASCII)
8527903	X	X						APL
8527908	X	X						SDLC
8527909	X		X					SDLC
8527911	X		X					SDLC
8527914	X		X					SDLC
8527977	X		X					Leased ASCII
8527978			X					3275-3
8527979				X				APL
8527980	X		X					SDLC
8527982			X					
8527983	X	X						APL
8527986			X					9600-bps RPQ
8527989	X		X					SDLC
8528255							X	VFIC
8528257	X		X					Leased ASCII
8528258			X					3275-3
8528261	X							Military Spec
8528267	X	X						APL

Figure 1-4 (Part 3 of 3). Feature and RPQ Card Caddy List

## FACILITIES ERROR RECOGNITION SYSTEM (FERS)

The IBM 3270 Information Display System user can display error information on the entire local or remote teleprocessing network from any 3270 display station in that network using 3270 FERS (FACILITY ERROR RECOGNITION SYSTEM).

The current version of FERS requires a DOS, OS, or VS operating system which will execute CICS (OS V2.3 - DOS Standard V1.2) supporting 3270 under BTAM. FERS traps the sense and status data from the TEP of CICS and records the data on a disk record. The user, SE, CE, or PSR can obtain an overview of the entire error activity on his TP network. He may then assess the efficiency of his TP network and use the resulting sense and status data for problem determination.

The program may be installed by either the customer's programmer or the PSR and is estimated to require two hours to install, which includes preparation and machine run time. The Service Aid is distributed on a DTR tape with a description manual. The tape is in source code with utility control cards to update an existing partitioned library.

### Highlights

- FERS is a self-teaching program so no formal training is required to use it effectively.
- To begin operation, clear the screen of a 3270 display unit, type FERS, and depress ENTER.
- The user can select from the first FERS screen the following display options:
  - Terminal — detail on a specific terminal error.
  - Control Unit — error count by terminal on a specific control unit.
  - Line — error count by control unit on a specific TP line.
  - All Lines — a recap of all TP lines on the system.
  - Describe — describe functions to aid the new user to operate FERS effectively.
  - FERS Info — optional data describing each terminal.
- Specific errors may be expanded to display the following:
  - Channel Status Word
  - 3270 status and sense
  - Response field and DEC flags
  - ECB completion code
  - BTAM OP code
  - Data length and residual byte count
  - Channel command
  - TP, OP code, time of day, and date
- The status and sense data is displayed in a hexadecimal form. Additional data (display screens) can be selected to provide a definition of the hex error data to eliminate the need for a reference manual at the terminal.
- All errors are time-stamped as they are recorded by FERS allowing correlation of type and frequency to be used in PROBLEM DETERMINATION.
- To aid in system coordination between the host and remote sites, the optional FERS INFO file is provided to display the location, name and type of all devices in the system, phone numbers and/or responsible personnel as needed.
- The first screen of the FERS display provides the symbolic address and polling address of the terminal being used.

### Ordering Information

FERS is available from Mechanicsburg and should be ordered using the following form numbers:

DOS — 1600 BPI 9 Trk, 229-7030

OS — 1600 BPI 9 Trk, 229-7029

Service Aid Description and Operations Manual, G229-7031

## 3270 SERVICE AIDS

### 3270 Coax Cable Check

The only cables supported for 3270 use are:

- RG62A/U — (indoors)
- RG62A/U special — (outdoor, underground)
- 2260 cable converted

The following procedure can be used for checking coax cables for 3270 via the use of the 2790 Line Tester. (The Bi Polar test is to be used).

1. Disconnect the coax cable being checked at both ends and leave unterminated.
2. Set counter test switch to off position.
3. Set mode switch to Bi Polar pulse.
4. Connect center conductor of coax to high side location on tester.
5. Connect shield to low side location on tester.
6. 453 scope settings should be as follows:
  - .5 usec time base
  - 1V per division
7. Probe center conductor at the 2790 tester end. Waveforms for various cable conditions (Figure 1-5) are as follows:
  - 1 — 1500 ft (457 m) of good coax cable.
  - 2 — Defective coax at beginning of 1500 ft (457 m).
  - 3 — Defective coax at end of 1500 ft (457 m).
  - 4 — Defective coax at approximately 1000 ft (305 m).

*Note 1:* Approximate cable length can be determined by 2.5 usec per 1000 ft (305 m) of cable.

*Note 2:* Pictures shown are approximately 200 ft (61 m) per division.

*Note 3:* Pictures 2, 3 & 4 are only samples of defective cables.

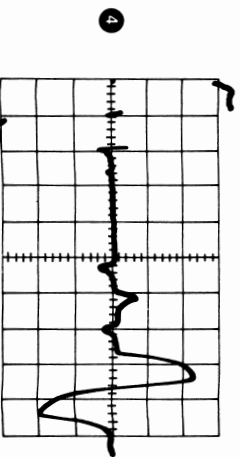
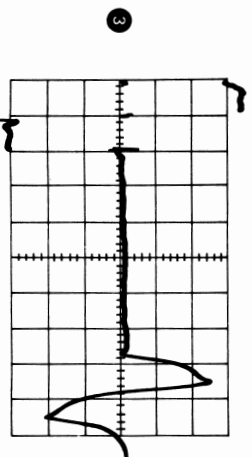
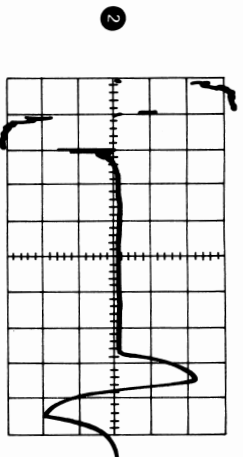
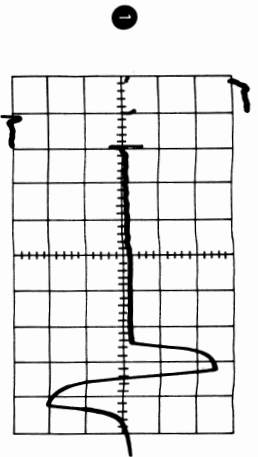

Figure 1-5. Waveforms of Various Cable Conditions

## AMP Tool

The AMP extraction tool, PN 452815, commonly used in repairing 029 and 059 machines, can be used successfully in removing AMP contacts found in the 3270 SIU (Switch Indicator Unit) and the power supply cables in the 3270 products. This tool may be ordered through the parts distribution center.

## Power Supply Mounting

### DANGER

When replacing the Low-Voltage Power Supply in the 3271, 3272, 3284, and 3286, tighten the two upper mounting screws in the machine frame. Failure to do this can result in injury if the power supply drops after removal of the front cover.

## Card Swapping

Power should be shut off when swapping cards in 3270 products.

Analysis of failure mechanisms in VTL cards returned from the field indicates a possible cause of failure was removing or inserting cards with power up.

Power should be shut off before replacing cards or any Field Replaceable Unit in 3270 products (3271, 3272, 3275, 3277, 3284, 3286, 3288, or 5275).

## Logic Manual IR Pack and MLTG Storage

### CAUTION

Corporate Safety Standards prohibits storage of combustible material inside machines unless there is an approved storage compartment provided. Due to physical limitations on the 3270 products, there are no storage compartments provided. Therefore, IR packs, logics, and manuals must be stored elsewhere.

If there are no logic carts at the customer location and it is necessary to provide a cart for 3270 manual storage, it is recommended that a mini logic cart PN 453644 be ordered. Wheels for this cart are not included and must be ordered under BM 1749000. This cart will hold 16 B size logic binders. Other carts that may be available in the branch office are the small system cart PN 453699, microfiche viewer carts PN 453195, and the 1401 small system scope carts.

## 3270 Card Holder Part Numbers

Part Number	Description
819407	Holds four cards, three high one wide (3271, 3272 buffer card holders)
819408	Holds one card, three high four wide (3271, 3272, 3275, 3277, 3284, 3286, 3288)
818002	Holds two cards, three high two wide (3271, 3272 device adapter card)
819295	Holds one card, two high four wide (3277)
2568970	Holds one card, three high two wide, and two cards, three high one wide (3284, 3286, 3288)
813761	Holds one card, three high two wide (9600 bps RPQ)

## Test Request Function For 3270s Using BTAM

The test request key function enables a CE to quickly check out a 3275 or 3277. They also provide an excellent means for operator familiarization.

It is recommended that the Request for Test (RFT) be installed in all 3270 installations. This is especially true for remote installations. There are a number of PTFs available to insure the successful installation of the RFT module. In addition the remote input message format has been changed.

Listed below are:

- A summary of all PTFs by system and release which contain all known RFT fixes.
- The release level of the format change.
- An example of the old and new format.

### OS BTAM

Release 21.0	apply all fixes in			
21.6	list beginning here	—————→	US02384	
21.7	apply all fixes from here	—————→	US02187 US03116 US03057 US01528 US03386 US03737 US04119 US04260 US04625 US05096 US04773	
21.8	apply all fixes from here	—————→	US05501 US05502 (Note: The US0550x PTFs can and should be applied to release 21.0, 21.6, and 21.7 systems, although the cover letter specifies only release 21.8).	US05503 US05508

Release 21.8 contains the RFT changes requiring a new format.

PTFs are forthcoming for all releases which will supersede the above PTFs and they will contain the fix for the 301 Abend problem and the new format change.

### OS/VS1 BTAM

Release 2.0	apply all fixes in list beginning here	—————→	UX00191 UX00302 UX00418
2.6	apply all fixes from here	—————→	UX00497 UX00569 UX00859
3.0	apply all fixes from here	—————→	UX01551 UX01543 UX01111 UX01426 UX01687 UX00812
3.1	apply all fixes from here	—————→	UX01064*

UX01064 contains the fix for 301 Abends and the new RFT format.

### OS/VS2 (SVM) BTAM

Release 1.0	apply all fixes in list beginning here	→	UY70008 UY70032 UY70035 UY70069
1.6	apply all fixes from here	→	UY70285 UY70286
1.7	apply all fixes from here	→	UY70557 UY70787 UY70927 UY70689*

UY700689 contains the fix for 301 Abends and the new RFT format change.

\*Not yet available.

### OS/VS2 (MVM) BTAM

Release 2.0	apply all of these PTFs	→	UZ00014 UZ00017 UZ00021*
-------------	-------------------------	---	--------------------------------

PTF UZ00021 and release 3.0 will contain the 301 Abend fix and the new RFT format change.

\*Not yet available.

### DOS BTAM

Release 27.1 37ON-469-02009  
(this PTF has the new RFT format)

### DOS/VS BTAM

Release 28 5745-00800  
Release 29 5745-01604  
Release 30 5745-02601

PTFs are forthcoming against Release 29, 30, and 31 to provide the new RFT format.

### RFT Format and Invoking Procedure:

REMOTE:

Old Format: XX YY N MMDD

Where: XX is a number specifying the desired test (23 through 28 for EBCDIC or 29 through 34 for ASCII).

YY is from 01-99 specifying the number of times the test shall be executed. (01 is recommended; the test will be sent to the printer only once regardless of the YY specification).

N is the number 4 (0 if system has the Dial feature).

MMDD is a sequence of four alphanumeric characters representing the hexadecimal addresses of the control unit and device. (This sequence is not required if your system has the Dial feature.)

Example: Run test 23, to control unit 2 device 3, Run test only once.

Type in 23014SSCC

↑↑↑↑ Shift key must be held.

New Format: The MMDD format is all that has changed. Using the example above

Type in 23014E2C3

↑ Shift key must be held.

Press the Test Request Key.

LOCAL: Position the cursor at position 0 on the unformatted screen. (Press the CLEAR key; then press the RESET key.)

Key in the RFT message in the format

XX YY N CUU

Where: XX is a number specifying the desired test (23 through 28 for EBCDIC or 29 through 34 for ASCII).

YY is any number from 01-99 specifying the number of times the test shall be executed. (01 is recommended.)

N is the number 3 – (specifies a 3 byte address follows).

CUU is the channel and unit address of the device (display or printer) to which the test is to be sent.

Note: Alphabetic characters must be entered in upper case.

Example: 230131E3

↑ Shift key must be held down.

Press the Test Request key.

The desired test should appear on the screen within a reasonable amount of time.

Note: Refer to "A Guide to Using the Test Request Feature" (GA27-2774-2) for details of additional testing. The new format will be included in the next update to this manual.

### Individual LED Replacement

PN 2391842 is now available for individual LED replacement for the Switch and Indicator Unit (SIU), 3271s and 3275s. If difficulty is experienced installing the leads through the guide on the 3275 LED card, they may be run over the card.

### CE General (Universal) Logic Probe Use On 3270

Logic Probe PN 453212

Instruction Manual SY27-0113

To use on 3270 products, proceed as follows:

1. Power leads (black & red)
  - a. Black lead 0 volts (or most negative voltage). Any D08 pin (ground).
  - b. Red lead 4 to 12 volts positive in relation to the black lead. Any D03 pin (+5 volts).
2. Test Probe Leads

Note: Signal and power leads are not common so it is necessary to use a signal ground lead.

- a. Signal probe – connect to signal source
  - b. Signal ground – any D08 pin
3. Technology Switch . . . . . Multi
  4. Latch Switch . . . . . None (unless used as babysitter)
  5. Gate Ref Switch . . . . . Not used

6. Level Indications
- a. Both lights on . . . . . Oscillating signal
  - b. Up light . . . . . 2.0 to 60.0 volts
  - c. Down light . . . . . 0.0 to 1.0 volts
  - d. No level . . . . . 1.0 to 2.0 volts

*Note:* Voltage greater than 60V (multi) or greater than 14V (MST 1, 2, or 4) will damage the probe.

## CONTROL UNIT SEQUENCE LATCHES AND TABLES OF SEQUENCES

### Sequence Latches

- Sequence 2 – Device Polling.
- a) Write Poll
  - b) Read Poll
  - c) Idle Poll

Sequence 3 – Sending data to a device, also backward tag flush.

Sequence 4 – Waiting for response from a device.  
e.g., Status, or Data in response to a Read Poll.

Sequence 5 – Receiving WCC or CCC.

Sequence 6 – Waiting for interface action.

Sequence 7 – Forward Tag flush also resetting modified data tags.

Sequence 8 – Reading or writing with interface.

### Table of Sequences

#### Write (Buffer Not Valid)

- Sequence 6 From selection
- Sequence 2 { Initial poll
- Sequence 4 { and response from the device
- Sequence 6 Wait for interface
- Sequence 5 Store WCC (Write Control Character)
- Sequence 2 Read poll (if data or reset modify data tags)
- Sequence 4 Receive 480 or 1920 characters
- Sequence 2 { Poll after fetch from buffer
- Sequence 4 { and wait for response from the device
- Sequence 7 Move data tags forward or reset
- Sequence 8 Receive data (Only if data is from local or remote interface)
- Sequence 6 No more data
- Sequence 2 Write poll (Signals device that control unit will transfer buffer to the device) } Only if the buffer has been modified.
- Sequence 3 Send 480 or 1920 bytes to the device }
- Sequence 2 { Ending poll
- Sequence 2 { Unlock keyboard and sound alarm or start print
- { send both control words
- Sequence 4 Response from the device
- Sequence 6 Wait for the interface

## Copy

- Sequence 6 From selection or succeeding command
- Sequence 2 { Initial poll (Only if not chained)
- Sequence 4 { and wait for response from the device
- Sequence 6 Wait for the interface
- Sequence 5 Store CCC (Copy Control Character) and get from address (device address to be copied)
- Sequence 2 { Initial poll (to from address)
- Sequence 4 { and wait for response from the device
- Sequence 2 Read poll (to from address)
- Sequence 4 Receive 480 or 1920 characters
- Sequence 2 { Poll after fetch of buffer (to from address)
- Sequence 4 { and wait for response from the device
- Sequence 5 Erase last 1440 bytes (Only if a copy 480 to 1920)
- Sequence 7 Move tags forward
- Sequence 2 Write poll
- Sequence 3 Send 480 or 1920 bytes
- Sequence 2 Poll (send CCC)
- Sequence 4 Wait for response from the device
- Sequence 6 Wait for the interface

## Read Buffer Or Read Modified

- Sequence 6 From initial selection or succeeding command
- Sequence 2 { Initial poll (only if not chained)
- Sequence 4 { and wait for response from the device
- Sequence 6 Wait for the interface
- Sequence 2 Read poll (if the buffer is not valid)
- Sequence 4 Receive 480 or 1920 characters
- Sequence 2 { Poll after fetch of the buffer
- Sequence 4 { and wait for response from the device
- Sequence 7 Move tags forward
- Sequence 8 Send data to the interface (channel or remote)
- Sequence 6 End of data or stop, wait for the interface

## Erase All Unprotected

- Sequence 6 From selection or succeeding command
- Sequence 2 { Initial poll (Only if not chained)
- Sequence 4 { and wait for response from the device
- Sequence 6 Wait for the interface
- Sequence 2 Poll, send erase all unprotected to device
- Sequence 4 Device should respond with Busy
- Sequence 6 { Poll and wait for a { Cycle sequences 6, 4 and 2
- Sequence 2 { not busy response { until a not busy response is received
- Sequence 4 {
- Sequence 6 Wait for the interface

(continued on next page)

## Select

- Sequence 6 From selection or succeeding command
- Sequence 2 { Initial poll (Only if not chained)
- Sequence 4 { and wait for response from the device
- Sequence 6 Wait for the interface
- Sequence 2 Read poll (if buffer is not valid)
- Sequence 4 Receive 480 or 1920 characters
- Sequence 2 { Poll after fetch of the buffer
- Sequence 4 { and wait for response from the device
- Sequence 7 Move tags forward
- Sequence 6 Wait for the interface

## Erase/Write

- Sequence 6 From selection or succeeding command
- Sequence 2 { Initial poll (Only if not chained)
- Sequence 4 { and wait for response from the device
- Sequence 6 Wait for the interface
- Sequence 5 Store WCC (Write Control Character) and erase the buffer
- Sequence 8 Receive data (Only if data follows)
- Sequence 6 No more data
- Sequence 2 Write poll (Signals device that control unit will transfer the buffer to the device)
- Sequence 3 Send 480 or 1920 bytes to the device
- Sequence 2 { Ending poll
- Sequence 2 { Unlock keyboard and sound alarm or start print;  
send both control words
- Sequence 4 Response from the device
- Sequence 6 Wait for the interface

## Attribute Characters, How to Enter and Display

To enter Attribute characters from the keyboard:

1. Jumper J2U02 (inhibit device check) to ground (D08).
2. Ground C2B08 while entering attributes.
3. If protected attributes have to be inserted, then all attributes have to be entered from the end of the display format to the beginning.
4. Remove all jumpers.

To display Attribute characters, jumper J2M13 or H2D07 to ground (D08).

(See Figure 1-6.)

Attribute character bit assignments are summarized as follows:

X	1	U/P	A/N	D/SPD	Reserved	MDT	
0	1	2	3	4	5	6	7
EBCDIC Bit	Field Description						
0	- Value determined by contents of bits 2–7. See Figure 1-25.						
1	- Must be a 1.						
2	- 0 = Unprotected 1 = Protected						
3	- 0 = Alphameric 1 = Numeric (causes automatic upshift of data entry keyboard)						
<i>Note:</i> Bits 2 and 3 equal to 11 causes an automatic skip. See text.							
4 & 5	- 00 = Display/not selector-pen detectable. 01 = Display/selector-pen detectable. 10 = Intensified display/selector-pen detectable. 11 = Nondisplay, nonprint, nondetectable.						
6	- Reserved. Must always be 0.						
7	- Modified Data Tag (MDT); identifies modified fields during Read Modified command operations.  0 = Field has not been modified. 1 = Field has been modified by the operator. Can also be set by program in data stream.						

*Note:* Bits 0 and 1 are not decoded when received by the 3270. When transferring characters to the CPU, bit 1 is a 1 and bit 0 is set (as shown in Figure 1-25) depending upon the character being transferred. All attribute characters are part of the defined character set. The default option (bits 2 through 7 all set to 0) results in an unprotected, alphameric, displayed, nondetectable field.

**Figure 1-6. Attribute Character Bit Definition**

## SCOPING PROCEDURE TO DETERMINE DEVICE CONDITION

This procedure is used when a device will not operate online, but no trouble can be found on the device. In this procedure, you do not have to take the system away from the customer to do the scoping. You will not interfere with the customer's use of the rest of the devices attached to the 3271 or 3272 in any way. Refer to Status Word and CU CW1 Scoping Points on Unique 3270 Box, in this section.

### 3271/3272 Poll Poll, and Display or Printer Status Detected at Device

1. 3277 poll poll
  - a. Sync plus on oscilloscope.
  - b. Use .2V/div. and 2  $\mu$ s/div. uncalibrated sweep rate to shrink the display down to fit the screen.
  - c. Probe G2J12.
    - (1) The first bit (bit 1) of CU CW1 is the 14th bit shown and bit 13 is the 26th (rightmost on the oscilloscope). This is because the actual CU CW1 is preceded by a dummy CU CW of all zeros (all bits off).
    - (2) To determine the status of the bits displayed (on/off), see Figure 1-14 (which shows the normal CU CW1 poll poll signal that will be seen) and Figure 1-16 for more information on the CU CW.
2. 3277 status word
  - a. Sync plus on oscilloscope.
  - b. Use 50 mV/div. and 1  $\mu$ s/div. uncalibrated sweep rate to shrink the display down to fit the screen.
  - c. Probe G2P12.
    - (1) The last bit on the right of the screen is bit 13. Count the bits from the right to the left to determine which bits are on or off. Refer to Figure 1-8 to see what the trace will look like, and to Figure 1-16 (display station status word) to determine what each bit is used to indicate.
    - (2) The busy bit will always be on.
    - (3) The trace for displays is inverted in relation to the trace for the printers.
3. 3284/3286 Mod. 1/2 poll poll
  - a. Sync minus on oscilloscope.
  - b. Use .2 mV/div. and 2  $\mu$ s/div. uncalibrated sweep rate, and shrink the display down to fit the screen.
  - c. Probe E2J13.
    - (1) The scope trace should look like Figure 1-13. The first bit (bit 1) of CU CW1 is the 14th bit shown, and bit 13 is the 26th (rightmost on the oscilloscope). This is because the actual CU CW1 is preceded by a dummy CU CW of all zeros (all bits off).
    - (2) To determine the status of the bits displayed (on/off), see Figure 1-13 (which shows the normal CU CW1 poll poll signal that will be seen) and Figure 1-16 for more information on the CU CW.
4. 3284/3286 Mod. 1/2 status word
  - a. Sync minus on oscilloscope.
  - b. Use .2V/div. and 1  $\mu$ s/div. uncalibrated sweep rate, and shrink the display down to fit the screen.
  - c. Probe C2D12.
    - (1) The last bit on the right of the screen is bit 13. Count the bits from the right to the left to determine which bits are on or off. Refer to Figure 1-9 to see what the trace will look like and to Figure 1-16 (printer status word) to determine what each bit is used to indicate.
    - (2) The busy bit and bit 1 will always be on, but you may not always see the busy bit on the oscilloscope.
    - (3) The trace for the printers is inverted in relation to the trace for the displays.

5. 3288 poll poll
  - a. Sync minus on oscilloscope.
  - b. Use .2V/div. and 2  $\mu$ s/div. uncalibrated sweep rate, and shrink the display down to fit the screen.
  - c. Probe G2J13.
    - (1) The scope trace should look like Figure 1-13. The first bit (bit 1) of CU CW1 is the 14th bit shown, and bit 13 is the 26th (rightmost on the oscilloscope.) This is because the actual CU CW1 is preceded by a dummy CU CW of all zeros (all bits off).
    - (2) To determine the status of the bits displayed (on/off), see Figure 1-13 which shows the normal CU CW1 poll poll signal that will be seen and Figure 1-16 for more information on the CU CW.
6. 3288 status word
  - a. Sync minus on oscilloscope.
  - b. Use .2V/div. and .5  $\mu$ s/div. uncalibrated sweep rate, and shrink the display down to fit the screen.
  - c. Probe F2M04.
    - (1) The last bit on the right of the screen is bit 13. Count the bits from the right to the left to determine which bits are on or off. Refer to Figure 1-9 to see what the trace will look like and to Figure 1-16 (printer status word) to determine what each bit is used to indicate.
    - (2) The busy bit and bit 1 will always be on, but you may not always see the busy bit on the oscilloscope.
    - (3) The trace for the printer is inverted in relation to the trace for the displays.

#### DISPLAY OR PRINTER STATUS WORD DETECTED ON 3271 CU (Figure 1-7 through 1-10)

*Note:* Connect one device at a time (other devices must be disconnected via coaxial cables or powered off).

1. If a previous detection was done for another device, proceed to step 6.
2. Power on the 3271 CU (SYNC SEARCH MUST LIGHT). If you use the SIU tool, plug it as per overlay "3271 - MPLXR CTRLS/10 REG & SR" and make following switch setup:

```
ON LINE/OFF LINE . . . . . OFF LINE
IND . . . . . UP POSITION
```

If you do not use the SIU, disconnect the cable to modem.

3. SYNC minus on oscilloscope.
4. Use 2 usec and 5V per division.
5. Probe on 3271 CU the line "-GTD DATA TO SR FROM DEVICE" PIN 01A-A1N2S11.
6. Connect to CU side the coaxial cable of device or printer (3284/3286) to be analyzed and power it on.
7. For waveshape shown on the oscilloscope, refer to Fig. 1-8 for the display or Fig. 1-9 for the printer.

*Note 1:* The first bit (on the left side of oscilloscope screen) is the "bit 1" of the status word and the last one (the rightmost one) is bit 13.

*Note 2:* To determine the status of bits (on/off), refer to Fig. 1-7. For repetition cycle of status word, refer to Fig. 1-10.

*Note 3:* Odd parity must be maintained for bits 1 through 12 only.

## DISPLAY OR PRINTER STATUS WORD DETECTED ON 3272 CU

*Note:* Connect one device at a time (other devices must be disconnected via coaxial cables or powered off).

1. If a previous detection was done for another device, proceed to step 7.
2. ENABLE/DISABLE switch on 3272 CU must be positioned to ENABLE (CPU must be powered on) or plug the SIU tools, and, with ENABLE/DISABLE switch on DISABLE, raise (on SIU) the OPER OUT switch.
3. Power on 3272 CU.
4. SYNC minus on oscilloscope.
5. Use 2 usec and 5V per division.
6. Probe on 3272 CU the line "GTD DATA TO SR FROM DEVICE" PIN 01A-A1N2S11.
7. Connect to CU side the coaxial cable of device or printer (3284/3286) to be analyzed and power it on.
8. For waveshape shown on the oscilloscope, refer to Fig. 1-8 for the display or Fig. 1-9 for the printer.

*Note 1:* The first bit (on the left side of oscilloscope screen) is bit 1 of the status word and the last one (the rightmost one) is bit 13.

*Note 2:* To determine the status of bits (on/off), refer to Fig. 1-7. For repetition cycle of status word, refer to Fig. 1-10.

*Note 3:* Odd parity must be maintained for bits 1 through 12 only.

## CU CW1 DETECTED ON 3277 DEVICE (Figures 1-11 through 1-14)

*Note:* Connect one display device at a time (repetition cycle of CU CW1 reduces while increasing the number of devices connected).

### 3277 Connected to 3271 CU

1. Power on the 3271 CU (SYNC SEARCH MUST LIGHT). If you use the SIU tool, plug it as per overlay "3271-P" LXR CTRLS/I/O REG & SP" and make the following switch setup:

ON LINE/OFF LINE . . . . .	OFF LINE
IND . . . . .	UP POSITION

If you do not use the SIU, disconnect the cable to modem.

2. SYNC oscilloscope on plus.
3. Use 5 usec and 5V per division.
4. Probe on 3277 the line "+ data" pin 01A-A1G2 J12.
5. For waveshape shown on the oscilloscope, refer to Fig. 1-14.

*Note 1:* The first bit (bit 1) of CU CW1 is the 14th bit shown and bit 13 is the 26th (rightmost on the oscilloscope). This is because the actual CU CW1 is preceded by a dummy CU CW1 of all ZEROES (all bits off).

*Note 2:* To determine the status of bits (on/off), refer to Fig. 1-12. For repetition cycle of CU CW1, refer to:

3272 . . . . .	Fig. 1-10
3271 . . . . .	Fig. 1-11

*Note 3:* Odd parity must be maintained for bits 1 through 12 only.

### 3277 Connected to 3272 CU

1. ENABLE/DISABLE switch on 3272 CU must be positioned to ENABLE (CPU must be powered on) or plug the SIU tool, and, with ENABLE/DISABLE switch on DISABLE, raise (on SIU) the OPER OUT switch.
2. Power on the 3272 CU.
3. SYNC plus on oscilloscope.
4. Use 5 usec and 5V per division.
5. Probe on 3277 the line "+ data" pin 01A-A1G2 J12.
6. For waveshape shown on the oscilloscope, refer to Fig. 1-14.

*Note 1:* The first bit (bit 1) of CU CW1 is the 14th bit shown and bit 13 is the 26th (rightmost on the oscilloscope). This is because the actual CU CW1 is preceded by a dummy CU CW1 of all ZEROES (all bits off).

*Note 2:* To determine the status of bits (on/off), refer to Fig. 1-12. For repetition cycle of CU CW1 refer to:

3272 . . . . . Fig. 1-10  
3271 . . . . . Fig. 1-11

*Note 3:* Odd parity must be maintained for bits 1 through 12 only.

### CU CW1 DETECTED ON PRINTER 3284/3286/3288

*Note:* Connect one device at a time (repetition cycle of CU CW1 reduces while increasing the number of devices).

### 3284/3286 Connected to 3271 CU

1. Power on the 3271 CU (SYNC SEARCH MUST LIGHT). If you use the SIU tool, plug it as per overlay "3271-MPLXR CTRLS/10 REG & SP" and make following switch set-up:

ON LINE/OFF LINE . . . . . OFF LINE  
IND . . . . . UP POSITION

If you do not use the SIU, disconnect the cable to modem.

2. SYNC minus on oscilloscope.
3. Use 5 usec and 5V per division.
4. Probe on 3284/3286 the line "-Coax data input" pin 01A-A1E2 J13. 3288 probe point is G2J13.
5. For waveshape shown on the oscilloscope, refer to Fig. 1-13.

### 3284/3286 Connected to 3272 CU

1. ENABLE/DSIABLE switch on 3272 CU must be positioned to ENABLE (CPU must be powered on) or plug the SIU tool, and, with ENABLE/DISABLE switch on DISABLE, raise (on SIU) the OPER OUT switch.
2. Power on the 3272 CU.
3. SYNC minus on oscilloscope.
4. Use 5 usec and 5V per division.
5. Probe on 3284/3286 the line "-Coax data input" pin 01A-01E2 J13. 3288 probe point is G2J13.
6. For waveshape shown on the oscilloscope, refer to Fig. 1-13.

*Note 1:* The first bit (bit 1) of CU CW1 is the 14th bit shown and bit 13 is the 26th (rightmost on the oscilloscope). This is because the actual CU CW1 is preceded by a dummy CU CW1 of all ZEROES (all bits off).

*Note 2:* To determine the status of bits (on/off), refer to Fig. 1-12. For repetition cycle of CU CW1, refer to:

3272 . . . . . Fig. 1-10

3271 . . . . . Fig. 1-11

*Note 3:* Odd parity must be maintained for bits 1 through 12 only.

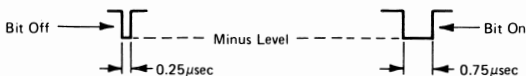

**Figure 1-7. Status Word Waveform**

- Bits On . . . . . 1,  
 13 (On if 1920 characters buffer)  
 13 (Off if 480 characters buffer)



**Figure 1-8. Display Status Word**

- Bits On . . . . . 1, 2, 12  
 13 (On if 1920 characters buffer)  
 13 (Off if 480 characters buffer)



**Figure 1-9. Printer Status Word**

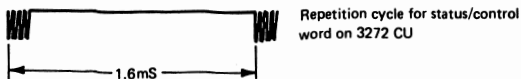

Figure 1-10. Status/Control Word (3272)

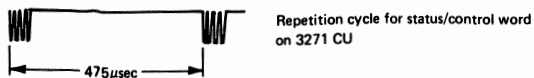

Figure 1-11. Status/Control Word (3271)

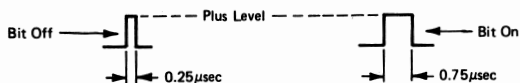

Figure 1-12. Status Word Waveform

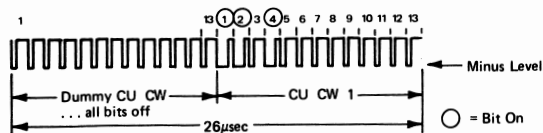

Figure 1-13. CU CW 1 Detected on 3284/3286/3288

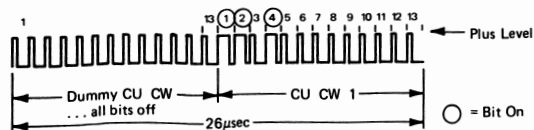
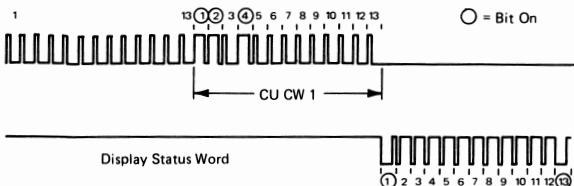

Figure 1-14. CU CW 1 Detected on 3277

## Visual Verification of Correct AID Encoding

The following setup enables the CE to visually verify the correct encoding of attention identification (AID) characters when operating the AID-generating keys on a keyboard attached to a 3277 display head or using Selector Pen.

Oscilloscope Setup	3270 Unit Involved	Probed Pin	Word Shown On The Oscilloscope
Channel 1	3277	01A-A1G2J12	CU CW 1
Channel 2	3271	01A-A1N2S11	Display Status Word
Sync +			
Channel 1 Only			
5 $\mu$ sec/div			
5V/div			



When operating the CLEAR, ENTER, PA, and PF keys, or using the light pen selector on a detectable field with immediate interrupt designator, the status of bits of the status word shown on channel 2 will vary according to related AID code.

### Status Word and CU CW 1 Scoping Points on Unique 3270 Box

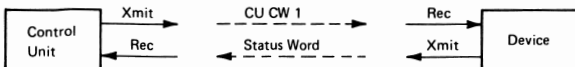

3271/3272	
Xmit	Rec
A1-N2S09	A1-N2S11

3277	
Xmit	Rec
A-G2P12	A-G2J12

3284/3286	
Xmit	Rec
A-C2D12	A-E2J13

3288	
Xmit	Rec
A-F2M04	A-G2J13



### CU Data Words

Figure 1-15 shows the formats for CU data words. The formats for transfer to the display station and to the printer are identical.

#### a. Character Format

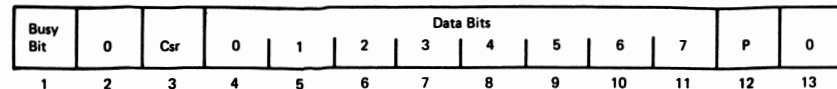

Bit 2 = 0 Identifies data  
 Bit 4 = 0 Identifies character data

#### b. Attribute Format

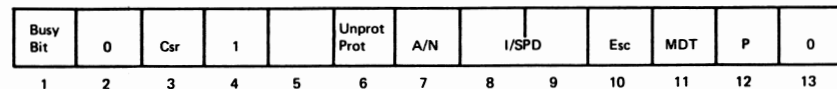

Bit 2 = 0 Identifies data  
 Bit 4 = 1 Identifies attribute data  
 Bit 5 = Unused  
 Bit 6 = 0 Unprotected data  
           = 1 Protected data  
 Bit 7 = 0 Alphanumeric data  
           = 1 Numeric only data  
 Bits 8,9 = 0,0 Normal intensity/nondetectable data  
           = 0,1 Normal intensity/selector pen detectable  
           = 1,0 High intensity/selector pen detectable  
           = 1,1 Nondisplay/nonprint/nondetectable  
 Bit 10 (Escape) = This bit is not decoded.  
 Bit 11 (Modified Data Tag) = 0 Field data not modified  
                                   = 1 Field data modified  
 Bits 5-11 all zeros - Default option  
                                   = Unprotected, A/N, normal intensity/nondetectable data.

Figure 1-15. CU Data Word Formats

### CU Control Words

Figure 1-16 shows the formats for CU control words.

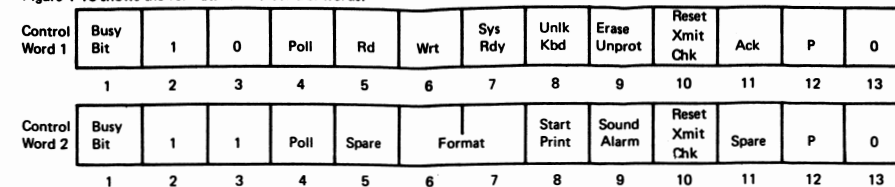

Bit 2 = 1 Identifies a control word  
 Bit 3 = 0 Identifies control word 1  
           = 1 Identifies control word 2  
 Bits 6 and 7 = 0,0 Variable line-length format, up to 132 char/line.  
                   = 0,1 40 char/line format  
                   = 1,0 64 char/line format  
                   = 1,1 80 char/line format

Note: Either or both control words may be transmitted to a selected Display Station or Printer.

#### Display Station or Printer Data Word

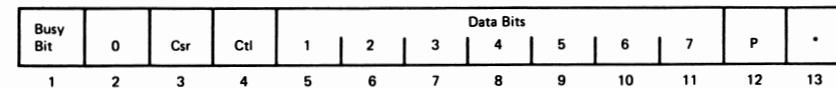

Bit 2 = 0 Identifies data word  
 Bit 3-11 = These 9 bits are fetched from the device buffer.  
 Bit 12 = Parity bit assigned by device  
 Bit 13 = 0 Identifies 480-byte device  
           = 1 Identifies 1920-byte device

#### Display Station Status Word

(Response to CU Poll)

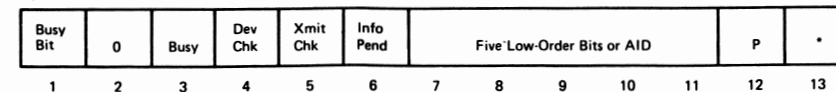

\* Bit 13 = 0 Identifies 480-byte device  
           = 1 Identifies 1920-byte device

#### Printer Status Word

(Response to CU Poll)

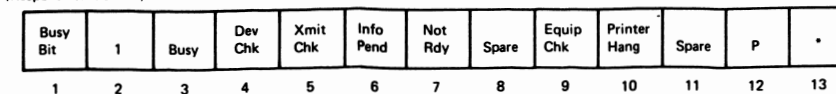

\* Bit 13 = 0 Identifies 480-byte device  
           = 1 Identifies 1920-byte device

Figure 1-16. CU Control Word Formats

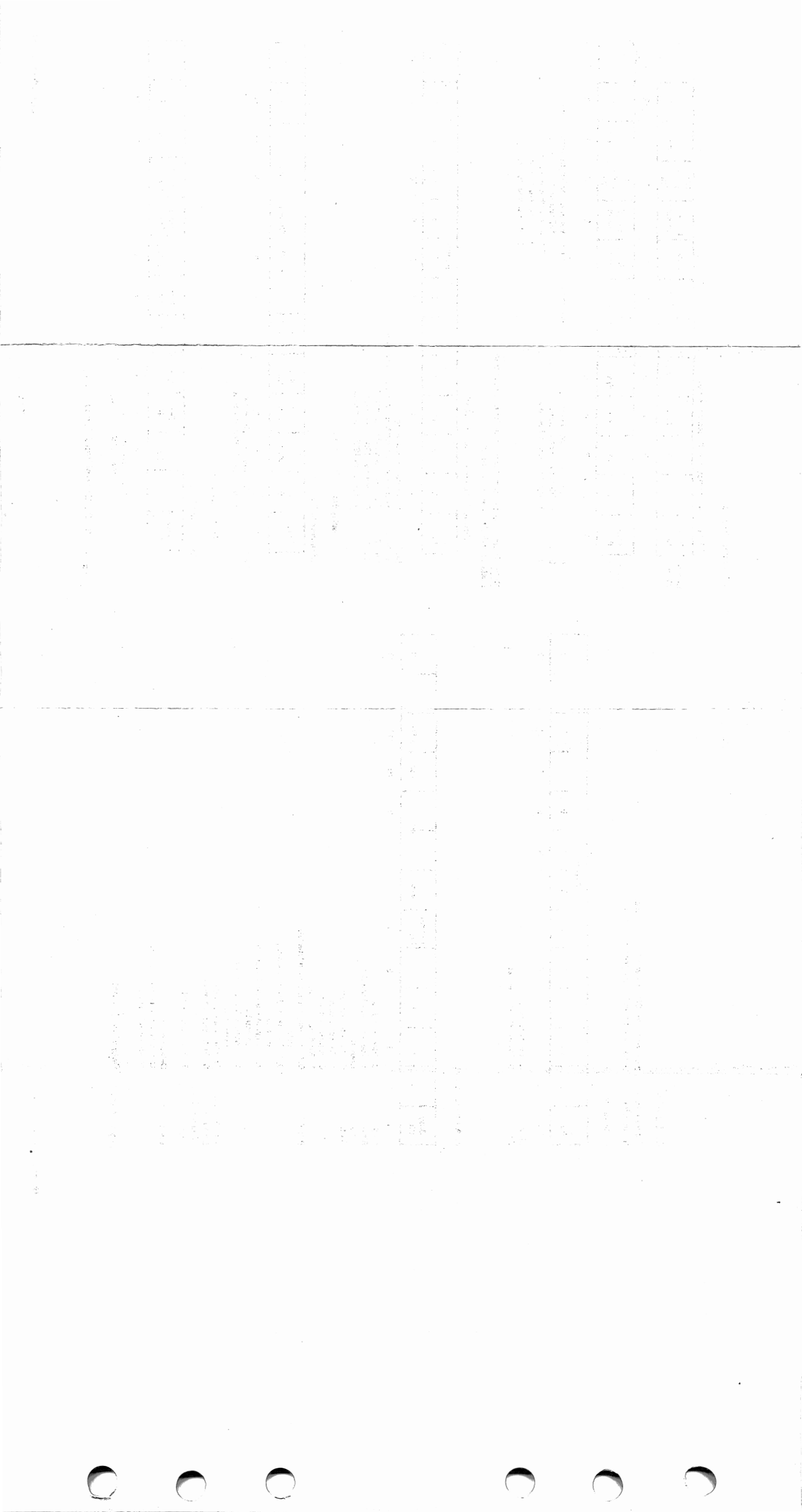

## Message Buffer Bit Assignment (Figures 1-17 and 1-18)

Bit	Attribute Byte	Character Byte (EBCDIC)
0	Parity	Parity (does not include cursor bit)
1	Always = 1	Data 1 (high order)
2	Prot/Unprot	Data 2
3	Alpha/Numeric	Data 3
4	Intensity/Sel Pen Detect	Data 4
5	Intensity/Sel Pen Detect	Data 5
6	Escape	Data 6
7	Modified Data Tag (MDT)	Data 7 (low order)
8	Control = 1	Control = 0
9	Cursor	Cursor

## MLPXR Shift Register Bits

Busy Bit	Parity	Cursor	Ctl	1	2	3	4	5	6	7
----------	--------	--------	-----	---	---	---	---	---	---	---

## Device SERDES is a 12 Position Shift Register

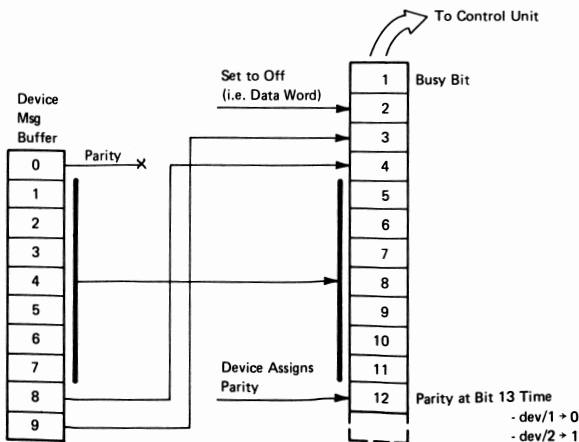

Figure 1-17. Device Buffer Transfer (Data Words) to Control Unit

## Device SERDES is a 12 Position Shift Register

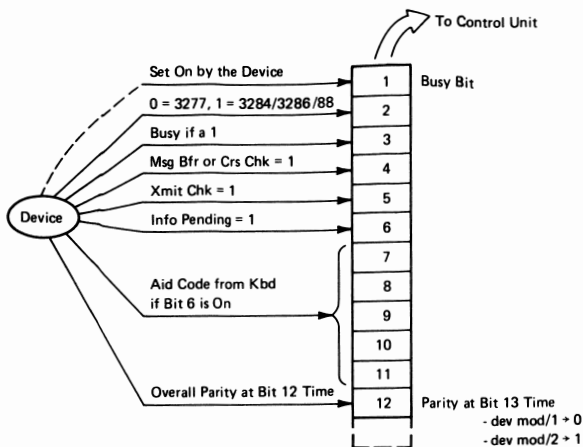

Figure 1-18. Status Word Sent by Device

### Character Code Assignments

Figures 1-19 through 1-24 give the character code assignments.

Hex 1 Bits 4567		00				01				10				11				Bits 0,1
		00	01	10	11	00	01	10	11	00	01	10	11	00	01	10	11	← 2,3
		0	1	2	3	4	5	6	7	8	9	A	B	C	D	E	F	← Hex 0
0000	0	NUL	DLE			SP	&	-									0	
0001	1	SOH	SBA				/		a	j				A	J		1	
0010	2	STX	EUA		SYN				b	k	s			B	K	S	2	
0011	3	ETX	IC						c	l	t			C	L	T	3	
0100	4								d	m	u			D	M	U	4	
0101	5	PT	NL						e	n	v			E	N	V	5	
0110	6			ETB					f	o	w			F	O	W	6	
0111	7			ESC	EOT				g	p	x			G	P	X	7	
1000	8								h	q	y			H	Q	Y	8	
1001	9		EM						i	r	z			I	R	Z	9	
1010	A					¢	!		:									
1011	B					.	\$	,	#									
1100	C	FF	DUP		RA	<	*	%	@									
1101	D		SF	ENQ	NAK	(	)	-	'									
1110	E		FM			+	;	>	=									
1111	F		ITB		SUB		⌋	?	"									

Figure 1-19. United States I/O Interface Code – EBCDIC

Notes:

- Character code assignments other than those shown within all outlined areas of this chart are undefined. If an undefined character code is programmed, the character that will be displayed is not specified. The character displayed by the 3277 or 3275 for a given undefined character code may be different for other devices. IBM reserves the right to change at any time the character displayed for an undefined character code.
- Lowercase alphabetic characters (shown within the dotted outlined area) are converted to uppercase by the display station or printer and displayed or printed as uppercase characters.
- NL, EM, FF, DUP, and FM control characters are displayed or printed as 5, 9, <, \*, and ; characters, respectively, except by the printer under format control, in which case NL and EM do not result in a character being printed.
- Bit 0 is assigned and bit 1 is always a 1 for the following characters: attribute, write control (WCC), copy control (CCC), CU and device address, buffer address, sense, and status. Bit 0 is assigned so that each character can be presented by a graphic character within the solid outlined areas of the chart. See Figure 1-24.
- This table also applies for Belgian, French, and Italian monospace I/O interface codes and graphics.
- The | character (hex 6A) is not displayed and is printed by the 3288 only.

					0	0	0	0	1	1	1	1
					0	0	1	1	0	0	1	1
b <sub>4</sub>	b <sub>3</sub>	b <sub>2</sub>	b <sub>1</sub>	Hex 0	0	1	2	3	4	5	6	7
↓	↓	↓	↓	Hex 1	0	1	2	3	4	5	6	7
0	0	0	0	0	NUL	DLE	SP	0	@	P		p
0	0	0	1	1	SOH	SBA	!	1	A	Q	a	q
0	0	1	0	2	STX	EUA	"	2	B	R	b	r
0	0	1	1	3	ETX	IC	#	3	C	S	c	s
0	1	0	0	4	EOT	RA	\$	4	D	T	d	t
0	1	0	1	5	ENQ	NAK	%	5	E	U	e	u
0	1	1	0	6		SYN	&	6	F	V	f	v
0	1	1	1	7		ETB	'	7	G	W	g	w
1	0	0	0	8			(	8	H	X	h	x
1	0	0	1	9	PT	EM	)	9	I	Y	i	y
1	0	1	0	A	NL	SUB	*	:	J	Z	j	z
1	0	1	1	B		ESC	+	;	K	[	k	
1	1	0	0	C	FF	DUP	,	<	L	\	l	
1	1	0	1	D		SF	-	=	M	]	m	
1	1	1	0	E		FM	.	>	N	^	n	
1	1	1	1	F		ITB	/	?	O	_	o	

Figure 1-20. United States I/O Interface Code – ASCII

Notes:

- Character code assignments other than those shown within all outlined areas of this chart are undefined. If an undefined character code is programmed, the character that will be displayed is not specified. The character displayed by the 3277 or 3275 for a given undefined character code may be different for other devices. IBM reserves the right to change at any time the character displayed for an undefined character code.
- Lowercase alphabetic characters (shown within the dotted outlined area) are converted to uppercase by the display station or printer and displayed or printed as uppercase characters.
- NL, EM, FF, DUP, and FM control characters are displayed or printed as 5, 9, <, \*, and ; characters, respectively, except by the printer under format control, in which case NL and EM do not result in a character being printed.
- Attribute, write control (WCC), copy control (CCC), CU and device address, buffer address, sense, and status characters are assigned as specified in Figure 1-24 so that each character can be represented by a graphic character within the solid outlined portion of this chart.
- ASCII A option displays and prints | and ̄ for interface codes 21 and 5E (hex), respectively. ASCII B option displays and prints ! and ̄ for codes 21 and 5E (hex), respectively.

LEGEND:



For ease of using ASCII characters with the SIU or the B-TDAT, the blocks with shaded corners indicate that the associated hex character needs "odd" parity and the high-order bit must be on. For example, **3** should be converted from hex 33 to hex B3 to maintain odd parity.

Hex	Bits 0,1	00				01				10				11				Hex 0
		00	01	10	11	00	01	10	11	00	01	10	11	00	01	10	11	
		0	1	2	3	4	5	6	7	8	9	A	B	C	D	E	F	
0000	0	NULL	DLE			SP	&	-			5	-	0					0
0001	1	SOH	SBA				/			a	i	0	1	A	J			1
0010	2	STX	EAU		SYN					b	k	s	2	B	K	S		2
0011	3	ETX	IC							c	l	t	3	C	L	T		3
0100	4									d	m	u	4	D	M	U		4
0101	5	PT	NL							e	n	v		E	N	V		5
0110	6			ETB						f	o	w	6	F	O	W		6
0111	7			ESC	EOT					g	p	x	7	G	P	X		7
1000	8									h	q	y	8	H	Q	Y		8
1001	9		EM							i	r	z		I	R	Z		
1010	A					†	!	9	:	≤	π	±	-					
1011	B					.	\$	,	#	(	)	L	J					
1100	C	FF	DUP		RA	<	*	%	@			┌	┐					
1101	D		SF	ENQ	NAK	(	)	-	.	(	)	[	]					
1110	E		FM			+	;	>	=	+		≥	#					
1111	F		ITB		SUB		¬	?	"	‡	■	●	SI					

Notes:  
 Only those data characters shown within the bold outlines can be printed by the 3288 printer with the Text Print feature installed, using the 64-character EBCDIC print belt.  
 JL, EM, DUP, FM, and SI control characters are printed as 5, 9, \*, and space characters, respectively, except when line length format is not specified, in which case NL and EM do not result in a character being printed.  
 Hex 6A; superscript 9 shown above, causes a broken vertical bar ( | ) to be printed when using the 64-character EBCDIC print belt.

Figure 1-21. Variant of EBCDIC for Text Print Feature

A	1		a	[
B	2	@	b	]
C	3	#	c	^
D	4	\$	d	v
E	5	%	e	NULL
F	6	^	f	FF
G	7	&	g	DUP
H	8	*	h	FM
I	9	(	i	NL
J	0	)	j	EM
K			k	
L	.	+	l	
M	:	:"	m	
N	;	;	n	
O	.	<	o	
P	.	>	p	
Q	.	>	q	
R	/	?	r	
S	SPACE		s	
T			t	
U			u	
V			v	
W			w	
X			x	
Y			y	
Z			z	

Notes:  
 1. During execution of a copy command, only the characters shown above are printed by the 3288 equipped with the Text Print Feature and using the 120-character TN print belt.  
 2. If the 120-character TN print belt is replaced with a 64-character EBCDIC print belt, only the characters in the first 3 columns are printed.  
 3. The control codes NULL, FF, DUP, FM, NL, and EM are printed as space, <, \*, ;, 5 and 9, respectively, regardless of which print belt is installed.  
 4. When additional character and control codes not shown above appear in the data stream, printing of undefined characters or erroneous printer operation results.

Figure 1-22. 3288 Text Print Feature Restricted Character Set (Copy Command)

		00				01				10				11				Bits 0.1
Hex 1		00	01	10	11	00	01	10	11	00	01	10	11	00	01	10	11	2,3
Bits 4567		0	1	2	3	4	5	6	7	8	9	A	B	C	D	E	F	Hex 0
0000	0	NUL	DLE			SP	&	-			□	-	a				0	
0001	1	SOH	SBA				/			a	j		e	A	J		1	
0010	2	STX	EUA		SYN					b	k	s	ζ	B	K	S	2	
0011	3	ETX	IC							c	l	t	ρ	C	L	T	3	
0100	4									d	m	u	ω	D	M	U	4	
0101	5	PT	NL							e	n	v		E	N	V	5	
0110	6			ETB						f	o	w	χ	F	O	W	6	
0111	7			ESC	EOT					g	p	x	\	G	P	X	7	
1000	8									h	q	v	÷	H	Q	Y	8	
1001	9		EM							i	r	z		I	R	Z	9	
1010	A					¢	!		:	↑	⊃	∩	▽					
1011	B					.	\$	,	#		⊂	∪	△					
1100	C		DUP		RA	<	*	%	@	≦		⊥	⊤					
1101	D		SF	ENQ	NAK	(	)	-	'	⌈	○	[	]					
1110	E		FM			+	;	>	=	⌋		≧	≠					
1111	F		ITB		SUB		∟	?	"	→	←	°						

**Note:**

- NL, EM, DUP, and FM control characters are displayed or printed as 5, 9, \*, and ; characters, respectively, except by the printer under format control, in which case NL and EM do not result in a character being printed.

Figure 1-23 (Part 1 of 2). Data Analysis – APL Feature Character Interchange Codes

Bits 4567	Hex 1	00				01				10				11				Bits 0,1	
		00	01	10	11	00	01	10	11	00	01	10	11	00	01	10	11	2,3	
		0	1	2	3	4	5	6	7	8	9	A	B	C	D	E	F	Hex 0	
0000	0										}	}	⊙						
0001	1										<u>A</u>	<u>J</u>	0	1					
0010	2										<u>B</u>	<u>K</u>	<u>S</u>	2	↓	I	⊖		
0011	3										<u>C</u>	<u>L</u>	<u>T</u>	3	..	!	⊠		
0100	4										<u>D</u>	<u>M</u>	<u>U</u>	4					
0101	5		5								<u>E</u>	<u>N</u>	<u>V</u>	⊗					
0110	6										<u>F</u>	<u>O</u>	<u>W</u>	6	∇	∇	⊖		
0111	7										<u>G</u>	<u>P</u>	<u>X</u>	7	⊗	∇	⊖		
1000	8										<u>H</u>	<u>Q</u>	<u>Y</u>	8					
1001	9		9								<u>I</u>	<u>R</u>	<u>Z</u>	⊗					
1010	A					~	□	^			1	2	3	n					
1011	B					~	⊖	v	~		π	L	J						
1100	C									-		Γ	⌈						
1101	D									(	)	⌈	T						
1110	E		±			φ	∕			+	⊗	⌈	⌊						
1111	F					⊖	∕			+	■	●	-						

**Notes:**

These codes, preceded by a hex ID control character, transmit the graphics shown.

- Codes which are not directly entered from Data Analysis – APL keyboard.
- ⊗ Codes B5, B9 & 9E may be used in program-to-terminal messages in lieu of codes 15, 19, & 1E for characters 5, 9, & ±.

**Figure 1-23 (Part 2 of 2). Data Analysis – APL Feature Character Interchange Codes**

Bits 2-7	Graphic	EBCDIC	ASCII	Bits 2-7	Graphic	EBCDIC	ASCII
00 0000	SP	40	20	10 0000	-	60	2D
00 0001	A	C1	41	10 0001	/	61	2F
00 0010	B	C2	42	10 0010	S	E2	53
00 0011	C	C3	43	10 0011	T	E3	54
00 0100	D	C4	44	10 0100	U	E4	55
00 0101	E	C5	45	10 0101	V	E5	56
00 0110	F	C6	46	10 0110	W	E6	57
00 0111	G	C7	47	10 0111	X	E7	58
00 1000	H	C8	48	10 1000	Y	E8	59
00 1001	I	C9	49	10 1001	Z	E9	5A
00 1010	¢, [	4A	5B	10 1010	¡ (EBCDIC)	6A	7C
00 1011	.	4B	2E	10 1011	,	6B	2C
00 1100	<	4C	3C	10 1100	%	6C	25
00 1101	(	4D	28	10 1101	-	6D	5F
00 1110	+	4E	2B	10 1110	>	6E	3E
00 1111	!, !	4F	21	10 1111	?	6F	3F
01 0000	&	50	26	11 0000	0	F0	30
01 0001	J	D1	4A	11 0001	1	F1	31
01 0010	K	D2	4B	11 0010	2	F2	32
01 0011	L	D3	4C	11 0011	3	F3	33
01 0100	M	D4	4D	11 0100	4	F4	34
01 0101	N	D5	4E	11 0101	5	F5	35
01 0110	O	D6	4F	11 0110	6	F6	36
01 0111	P	D7	50	11 0111	7	F7	37
01 1000	Q	D8	51	11 1000	8	F8	38
01 1001	R	D9	52	11 1001	9	F9	39
01 1010	!, ]	5A	5D	11 1010	:	7A	3A
01 1011	\$	5B	24	11 1011	#	7B	23
01 1100	*	5C	2A	11 1100	@	7C	40
01 1101	)	5D	29	11 1101	'	7D	27
01 1110	;	5E	3B	11 1110	=	7E	3D
01 1111	¬, ^	5F	5E	11 1111	"	7F	22

Figure 1-24. Assignments for Internal 6-Bit Structured Data

*Note:* The following characters are internally handled as 6-bit structured data: graphic, attribute, AID, write control (WCC), copy control (CCC), CU and device address, buffer address, status, and sense. When any of these characters is received by the CU, only the low-order 6 bits are used and the rest are ignored. When any of these characters is transmitted to the program, the CU assigns the appropriate EBCDIC code. If transmission is in ASCII, the CU translates the EBCDIC code to ASCII code prior to transmission.

For example, to use this table to determine the hex code transmitted for an attribute character, first determine the values of bits 2-7. Select this bit configuration in the table under "Bits 2-7". The hex code that will be transmitted (either in EBCDIC or ASCII) is to the right of the bit configuration.

Use this table also to determine equivalent EBCDIC and ASCII hex codes and their associated graphic characters. See Figure 1-20, Note 5, for ASCII A and B graphic character differences for ASCII codes 21 and 5E (hex).

Graphic characters for the United States I/O interface codes are shown. Graphic characters for EBCDIC 4A, 5A, 5B, 7B, 7C, and 7F might differ for particular World Trade I/O interface codes.

## 3270 COMMANDS (Figure 1-25)

Four basic types of commands are executed by the 3270 systems:

1. Write commands, which are used to transfer data and orders from main storage to the 3270 system.
2. Read commands, which transfer 3270 buffer data, keyboard key data, and, for remote configurations, status information to main storage.
3. Control commands, which cause certain printer or display station operations.
4. Sense commands (local configurations only), which transfer to main storage a byte of sense data that reflects certain control or check conditions existing in the device or control unit to which the command was addressed.

Command	Local	Remote		
	EBCDIC Hex	EBCDIC Hex	ASCII Hex	Graphic
Write	01	F1	31	1
Erase/Write	05	F5	35	5
Read Buffer	02	F2	32	2
Read Modified	06	F6	36	6
Copy	N/A	F7	37	7
Select	0B	N/A	N/A	N/A
Erase All				
Unprotected	0F	6F	3F	?
No Operation	03	N/A	N/A	N/A
Sense	04	N/A	N/A	N/A

Figure 1-25. Local and Remote Command Codes

### 3271 and 3275 Remote Commands (EBCDIC only)

Initial Selection	General Poll	Specific Poll
32 - SYN	32 - SYN	32 - SYN
32 - SYN	32 - SYN	32 - SYN
60 - Cu Add.	40 - Cu Poll	40 - Cu Poll
60 - Cu Add.	40 - Cu Poll	40 - Cu Poll
40 - Dev Add.	7F - Gen Poll	40 - Dev Add.
40 - Dev Add.	7F - Gen Poll	40 - Dev Add.
2D - ENQ	2D - ENQ	2D - ENQ
Blank - End Pad	Blank - End Pad	Blank - End Pad
Turnaround (Rcv)	Turnaround (Rcv)	Turnaround (Rcv)
55 - Start Pad	55 - Start Pad	55 - Start Pad
32 - SYN	32 - SYN	32 - SYN
32 - SYN	32 - SYN	32 - SYN
10 - DLE	37 - EOT	37 - EOT
70 - ACK 0	FF - End Pad	FF - End Pad
FF - End Pad		
Specific Poll w/Status Msg	Write from Init Selection	Init Selec w/Error Status
32 - SYN	32 - SYN	32 - SYN
32 - SYN	32 - SYN	32 - SYN
40 - Cu Poll	02 - STX	60 - Cu Add
40 - Cu Poll	27 - ESC	60 - Cu Add
40 - Dev Add	F1 - Write	40 - Dev Add
40 - Dev Add	40 - WCC	40 - Dev Add
2D - ENQ	Data	2D - ENQ
Blank - End Pad	03 - ETX	Blank - End Pad
Turnaround (Rcv)	03 - BCC	Turnaround (Rcv)

### 3271 and 3275 Remote Commands (EBCDIC only) (cont)

Specific Poll w/Status Msg	Write from Init Selection	Init Selec w/Error Status
55 - Start Pad	03 - BCC	55 - Start Pad
32 - SYN	Blank- End Pad	32 - SYN
32 - SYN	Turnaround (Rcv)	32 - SYN
01 - SOH	55 - Start Pad	10 - DLE
6C - %	32 - SYN	7C - RVI
D9 - R	32 - SYN	FF - End Pad
02 - STX	10 - DLE	
40 - Cu Poll	61 - ACK 1	
40 - Dev Add	FF - End Pad	
40 - S/S 0		
C1 - S/S 1		
03 - ETX		
CRC 1 - BCC		
CRC 2 - BCC		
FF - End Pad		

#### Read Modified From Initial Selection

32 - SYN	Mod Field Address
32 - SYN	Mod Field Address
02 - STX	Data
27 - ESC	03 - ETX
F6 - Read Mod	CRC 1 - BCC
03 - ETX	CRC 2 - BCC
CRC 1 - BCC	FF - End Pad
CRC 2 - BCC	Turnaround (Xmit)
Blank - End Pad	32 - SYN
Turnaround (Rcv)	32 - SYN
55 - Start Pad	10 - DLE
32 - SYN	61 - ACK 1
32 - SYN	Blank - End Pad
02 - STX	Turnaround (Rcv)
40 - Cu Add	55 - Start Pad
40 - Dev Add	32 - SYN
AID Char. - AID	32 - SYN
Cursor Add	37 - EOT
Cursor Add	FF - End Pad
11 - SBA	

### 3270 COMMANDS, AIDs, CCs, ORDERS, ADDRESSING, AND STATUS AND SENSE

See Figures 1-26 through 1-40.

AID	Hex Character (EBCDIC)	Hex Character (ASCII)	Graphic Character	Read Modified Command Operation	Resultant Transfer to CPU
No AID generated (Display or Display Station)	60	2D	—	Rd Mod	If performing a remote polling operation, no read operation occurs; otherwise, field addresses and text in the modified fields are transferred.
No AID generated (Printer)	E8	59	Y	Rd Mod	
ENTER key	7D	27	'	Rd Mod	AID code and cursor address, followed by an SBA order, attribute address +1, and text for each modified field. Nulls are suppressed.
PF 1 key	F1	31	1	Rd Mod	
PF 2 key	F2	32	2	Rd Mod	
PF 3 key	F3	33	3	Rd Mod	
PF 4 key	F4	34	4	Rd Mod	
PF 5 key	F5	35	5	Rd Mod	
PF 6 key	F6	36	6	Rd Mod	
PF 7 key	F7	37	7	Rd Mod	
PF 8 key	F8	38	8	Rd Mod	
PF 9 key	F9	39	9	Rd Mod	
PF 10 key	7A	3A	:	Rd Mod	
PF 11 key	7B	23	#	Rd Mod	
PF 12 key	7C	40	@	Rd Mod	
Operator Identification Card Reader	E6	57	W	Rd Mod	
Selector Pen Attention	7E	3D	=	Rd Mod	AID code, cursor address, and field addresses only; no data.
PA 1 key	6C	25	%	Short Rd	AID code only.
PA 2 (CNCL) key	6E	3E	>	Short Rd	
PA 3 key	6B	2C	,	Short Rd	
CLEAR key	6D	5F	—	Short Rd	
TEST REQ key	F0	30	0	Tst Req Rd	A test request message. AID transferred on Read Buffer only.

Note: Graphic characters for the United States I/O interface codes are shown.

Figure 1-26. Attention ID (AID) Configurations

Bit	Explanation
0	Determined by the contents of bits 2–7 as shown in Figure 1-24.
1	Always a 1.
2, 3	Define the printout format, as follows: = 00 - The NL order in the data stream determines print line length. = 01 - Specifies 40-character print line. = 10 - Specifies 64-character print line. = 11 - Specifies 80-character print line.
4	Start Printer bit. When set to 1, initiates a printout operation at completion of the write operation.
5	The Sound Alarm bit. When set to 1, sounds the audible alarm at the selected device at the end of the operation if that device has an audible alarm.
6	The Keyboard Restore bit. When set to 1, restores operation of the keyboard by resetting the INPUT INHIBITED indicator. It also resets the AID byte at the termination of the I/O command.
7	Reset MDT bits. When set to 1, all MDT bits in the selected devices' existing buffer data are reset before any data is written or orders are executed.

Figure 1-27. Write Control Character (WCC)

Bit	Explanation
0	Determined by the contents of bits 2-7 as shown in Figure 1-24.
1	Always a 1.
2, 3	Define the printout format as follows: = 00 - The NL order in the data stream determines print line length. = 01 - Specifies a 40-character print line. = 10 - Specifies a 64-character print line. = 11 - Specifies an 80-character print line.
4	The Start Printer bit. When set to 1, initiates a printout operation at the "to" device after buffer transfers are completed.
5	The Sound Alarm bit. When set to 1, sounds the audible alarm at the "to" device after buffer transfers are completed if that device has an audible alarm.
6, 7	Define the type of data to be copied as follows: = 00 - Only attribute characters are copied. = 01 - Attribute characters and unprotected alphanumeric fields (including nulls) are copied. Nulls are transferred for the alphanumeric characters not copied from the protected fields. = 10 - All attribute characters and protected alphanumeric fields (including nulls) are copied. Nulls are transferred for the alphanumeric characters not copied from the unprotected fields. = 11 - The entire contents of the storage buffer (including nulls) are copied.

Figure 1-28. Copy Control Character (CCC)

Bit	Name	Significance
0	Command Reject (CR)	Set if the 3272 has received an invalid command; the valid commands are listed in Figure 1-25.
1	Intervention Required (IR)	Set if a command, other than Sense, was addressed to a device that is unavailable or is in the "not ready" condition.
2	Bus Out Check (BOC)	Set if the 3272 has detected bad parity on any command or data byte received from the channel.
3	Equipment Check (EC)	Set if: (1) the 3272 has asynchronously detected a parity check on data received from a device in response to an internal poll for attention status (the internal poll is tried twice before EC is set), (2) a printer error occurs. If this is a device-detected condition, Unit Specify is also set.
4	Data Check (DC)	Set if: (1) the 3272 or a device has detected bad parity on data transferred internally or between the 3272 and a device during command operations, (2) a 3277 has detected a cursor check, or (3) a device has detected a buffer check. If this is a device-detected condition, Unit Specify is also set.
5	Unit Specify (US)	Set if the sense bits resulted from a device-detected error.
6	Control Check (CC)	Set when the 3272 has detected a timeout condition. (The addressed device fails to perform a specified operation or respond to the 3272 within a specified period of time.)
7	Operation Check (OC)	Set when the 3272 has received a valid command or order that it cannot execute, as follows: <ol style="list-style-type: none"> <li>1. SBA, RA, or EUA order specifies an illegal buffer address.</li> <li>2. Write data stream ends before all required bytes of SBA, RA, EUA, or SF order sequence are received.</li> <li>3. Write, or Erase/Write with Start Print bit set in WCC, is chained to the next command; the print operation is suppressed.</li> </ol>

Figure 1-29. Sense Bit Description

Order Sequence Order	Byte 1 (Order Code)		Byte 2	Byte 3	Byte 4
	EBCDIC (Hex)	ASCII (Hex)			
Start Field (SF)	1D	1D	Attribute Character <sup>1</sup>		
Set Buffer Address (SBA)	11	11	1st Address Byte <sup>3</sup>	2nd Address Byte <sup>3</sup>	
Insert Cursor (IC)	13	13			
Program Tab (PT)	05	09			
Repeat to Address (RA)	3C	14	1st Address Byte <sup>3</sup>	2nd Address Byte <sup>3</sup>	Character to Be Repeated <sup>2</sup>
Erase Unprotected to Address (EUA)	12	12	1st Address Byte <sup>3</sup>	2nd Address Byte <sup>3</sup>	

*Notes:*

1. Figure 1-6 shows attribute byte and Figure 1-24 shows coding of this byte.
2. Figures 1-19 and 1-20 show coding of this byte.
3. ASCII requires odd parity to be maintained.

**Figure 1-30. Buffer Orders and Order Codes**

3272 No.	8-bit Local Address Byte		Device No.	4 5 6 7 (XXXX)
	3272	Device		
	0 1 2 3	4 5 6 7		
0	0000	XXXX	0	0000
1	0001	XXXX	1	0001
2	0010	XXXX	2	0010
3	0011	XXXX	3	0011
4	0100	XXXX	4	0100
5	0101	XXXX	5	0101
6	0110	XXXX	6	0110
7	0111	XXXX	7	0111
8	1000	XXXX	8	1000
9	1001	XXXX	9	1001
10	1010	XXXX	10	1010
11	1011	XXXX	11	1011
12	1100	XXXX	12	1100
13	1101	XXXX	13	1101
14	1110	XXXX	14	1110
15	1111	XXXX	15	1111

Figure 1-31. 3272 and Device Addressing – 16 or Fewer Devices per 3272

3272 No.	8-bit Local Address Byte		Device No.	3 4 5 6 7 (XXXXX)	Device No.	3 4 5 6 7 (XXXXX)
	3272	Device				
	0 1 2	3 4 5 6 7				
0	000	XXXXX	0	00000	16	10000
2	001	XXXXX	1	00001	17	10001
4	010	XXXXX	2	00010	18	10010
6	011	XXXXX	3	00011	19	10011
8	100	XXXXX	4	00100	20	10100
10	101	XXXXX	5	00101	21	10101
12	110	XXXXX	6	00110	22	10110
14	111	XXXXX	7	00111	23	10111
			8	01000	24	11000
			9	01001	25	11001
			10	01010	26	11010
			11	01011	27	11011
			12	01100	28	11100
			13	01101	29	11101
			14	01110	30	11110
			15	01111	31	11111

Note: 3272 CU Nos. 1, 3, 5, 7, 9, 11, 13, and 15 cannot be assigned when attached devices are assigned Device No. 16 or greater.

Figure 1-32. 3272 and Device Addressing – 17 or More Devices per 3272

Bit	Name	Condition
0	Attention (A)	Indicates a request for service from a 3277 attached to 3272. Set as result of certain keyboard, selector pen, or card reader activity at 3277 (see Figure 1-26). Program should respond by issuing a Read Modified command (chained from a Select command if multiplexer channel) to the 3277 requesting attention. Attention bit is also set with Unit Check bit as result of asynchronously detected equipment malfunction; in this case, program should respond by issuing a Sense command.
1	Status Modifier (SM)	Is set, with Busy bit, in initial status byte to indicate that there is pending status for a device other than the one selected.
2	Control Unit End (CUE)	Is set following a busy condition, after pending status is cleared or when control unit is no longer busy, to indicate that 3272 is now not busy and is free to accept a new command.
3	Busy (B)	Is set alone in initial status byte when addressed device is busy because it is performing a print operation or an Erase All Unprotected command. Set with SM when addressed 3272 is busy. When the channel addresses a device other than the one that is busy and control unit is not busy, addressed device becomes selected and the command is honored. Busy bit is also set with pending status if addressed device has such status; if pending status is for a device other than the one addressed, Status Modifier bit is also set.
4	Channel End (CE)	Indicates 3272/channel data transfer operations are completed. Is set alone (1) in initial status for Select or Erase All Unprotected command, or (2) as ending status for Write or Erase/Write command; in both cases, Device End status is sent asynchronously when device operations (command execution or 3272-to-device buffer transfer) are completed. Is set with Device End, to indicate that 3272 and device operations (except printing) are completed (1) in initial status for No Operation command, (2) in ending status for Read Buffer, Read Modified, or Sense command, or (3) asynchronously if only Channel End status was pending and the device operation is completed before the channel accepts status. Is set with Device End and Unit Exception in initial status for Read or Write command if addressed device is busy executing another command.
5	Device End (DE)	Indicates that 3272 and device have completed all command operations and are free to execute another command. Is set (1) in initial status for No Operation command, (2) in ending status for Read Buffer, Read Modified, or Sense command, and (3) in asynchronous status for Write, Erase/Write, Select, or Erase All Unprotected command.
6	Unit Check (UC)	Is set when an irregular program or equipment condition is detected by 3272 or the device. Program should always respond to Unit Check status by issuing a Sense command for further definition of condition.
7	Unit Exception (UE)	Is set in ending status (synchronous or asynchronous) when 3272 has attempted to execute a command but has found, after initial status was returned, that addressed device was busy.

Figure 1-33. Status Byte Bit Assignments

Status <sup>1</sup> (Hex)	Sense (Hex)	Display	Printer	Error Recovery Procedure	Condition
All Zeros (00)		X	X		Normal status for any command other than No Operation, Select, or Erase All Unprotected.
CE (08)		X	X		Normal status for a Select or Erase All Unprotected command.
CE, DE (0C)		X	X		Normal status for a No Operation command.
UC (02)	BOC (20)	X	X	1	A parity check was detected on the command byte.
UC (02)	IR (40)	X	X	2	A command other than Sense was addressed to a device that the 3272 has recorded as "unavailable" or "not ready".
UC (02)	CR (80)	X	X	3	An invalid command was issued to 3272.
B (10)		X	X		Response to a command addressed to a device which is being serviced by 3272 or which is completing a previously issued command.
B, SM (50)		X	X		Response to a command addressed to a device other than device whose status is pending or device being serviced by 3272.

*Note 1.* If a SIOF is executed by the channel, unchained initial status becomes ending status.

**Figure 1-34. Initial Status and Sense Conditions – Local**

Status (Hex)	Sense (Hex)	Display	Printer	Error Recovery Procedure	Condition
CE <sup>2</sup> (08)		X	X		Sent at end of data stream on a Write or Erase/Write command.
CE, DE <sup>1,2</sup> (0C)		X	X		Sent at end of data stream on a Read Buffer, Read Modified, or Sense command or when channel byte count goes to zero on a Read Modified or Read Buffer command.
CE, DE, UC <sup>1</sup> (0E)	BOC (20)	X	X	10	The 3272 detected a parity error on a character in data stream of a Write or Erase/Write command.
CE, DE, UC <sup>1,2</sup> (0E)	DC, US (0C)	X	X	1	Addressed device detected a parity or cursor check during a Write, Read Buffer, or Read Modified command.
CE, DE, UC <sup>1,2</sup> (0E)	DC (08)	X	X	1	The 3272 detected a cursor or parity check during receipt of data stream on a Write or Erase/Write command.
CE, DE, UC <sup>1,2</sup> (0E)	DC (08)	X	X	10	The 3272 detected a cursor or parity check during transmission of data stream on a Read Buffer or Read Modified command.
CE, DE, UC <sup>1,2</sup> (0E)	CC (02)	X	X	10	Addressed device failed to respond in a specified period of time to an Erase/Write command or an unchained Read Buffer, Read Modified, or Write command.

Figure 1-35 (Part 1 of 2). Ending Status and Sense Conditions – Local

Status (Hex)	Sense (Hex)	Display	Printer	Error Recovery Procedure	Condition
CE, DE, UC <sup>1</sup> (0E)	OC (01)	X	X	3	The 3272 received an illegal buffer address in data stream of a Write or Erase/Write command, or data stream ended before providing all characters required for an SBA, RA, SF, or EUA order on a Write or Erase/Write command.
CE, DE, UE <sup>1,2</sup> (0D)		X	X	9	The 3272 attempted to perform a Read Buffer, Read Modified, Write or Erase/Write command but found, after returning initial status, that the addressed device was "busy".

**Notes:**

1. If this status is stacked by the channel, CUE could be generated and combined with it before the stacked status is accepted by the channel.
2. Occurs if a Start IO Fast Release (SIOF) is executed by the channel for Select, Erase All Unprotected, or No Operation.

**Figure 1-35 (Part 2 of 2). Ending Status and Sense Conditions – Local**

Status <sup>1</sup> (Hex)	Sense (Hex)	Display	Printer	Error Recovery Procedure	Condition
A (80)		X			An attention-generating action (e.g., program access key has been depressed) was performed by the operator.
DE (04)		X	X		<p>The 3272-to-device buffer transfer is completed on a Write or Erase/Write command which did not start a printer.</p> <p>The device becomes "not busy" after completing an Erase All Unprotected command or the printer becomes "not busy" after completing a printout.</p> <p>The device-to-3272 buffer transfer is completed on a Select command.</p> <p>A device changes from "not available" to "available" or from "not ready" to "ready".</p> <p>A device becomes "not busy" after having previously sent Unit Exception when the 3272 attempted to execute a command with the device when it was "busy".</p> <p>The 3272 ONLINE/OFFLINE switch is thrown from OFFLINE to ONLINE. This causes each "available" device to present a Device End to the channel.</p>
A, DE (84)		X			The 3272 is thrown from OFFLINE to ONLINE and an attention-generating action (e.g., program access key has been depressed) was performed by the operator.
A, UC (82)	EC (10)	X	X	5	An idle 3272 polled a device twice and detected a "transmit" parity check each time on the data in the device reply.

Figure 1-36 (Part 1 of 3). Asynchronous Status and Sense Conditions — Local

Status <sup>1</sup> (Hex)	Sense (Hex)	Display	Printer	Error Recovery Procedure	Condition
A, UC (82)	DC, US (0C)	X	X	1	An idle device detected a parity check or cursor check in its buffer.
A, DE, UC (86)	DC, US (0C)	X	X	4 or 8	A device changes from "not available" to "available" or from "not ready" to "ready" and has detected a parity check or cursor check in its buffer or a printer detected parity check while printing.
A, DE, UC (86)	IR (40)		X	6	The addressed printer became Not Ready (out of paper or cover open) before completion of a print operation.
DE, UC (06)	IR (40)		X	6	A command attempting to start a printer found it Not Ready.
A, DE, UC (86)	IR, EC, US (54)		X	6	A printer became mechanically disabled during a printout and an automatic recovery was not successful, the printer CARRIAGE MOTOR POWER switch was off, or the switch fuse was blown.
DE, UC (06)	IR, EC, US (54)		X	6	A command attempted to start a print operation, but the printer CARRIAGE MOTOR POWER switch is turned off.
A, DE, UC (86)	EC, US (14)		X	7	A printer character generator or sync check error occurred or the printer became mechanically disabled during printout, but restored itself.

Figure 1-36 (Part 2 of 3). Asynchronous Status and Sense Conditions — Local

Status <sup>1</sup> (Hex)	Sense (Hex)	Display	Printer	Error Recovery Procedure	Condition
DE, UC (06)	DC (08)	X	X	10	During a Select or Erase/Write command the 3272 (1) detected a parity or cursor error, or (2) detected a parity check on data received from the addressed device in response to an internal poll during a command.
DE, UC (06)	DC (08)	X	X	1	During a Write command, the 3272 (1) detected a parity or cursor error, or (2) detected a parity check on data received from the addressed device in response to an internal poll during a command.
DE, UC (06)	DC, US (0C)	X	X	1	The addressed device detected a parity or cursor check while executing a Select, Write, Erase/Write, or Erase All Unprotected command.
DE, UC (06)	OC (01)	X	X	3	A Write or Erase/Write command, containing a WCC with a Start Print bit, is chained to a subsequent command.
DE, UC (06)	CC (02)	X	X	10	The addressed device failed to respond in a specified period of time to a Select, Write, Erase/Write, or Erase All Unprotected command.
DE, UE (05)		X		9	The 3272 attempted to perform a Select or Erase All Unprotected command, but found, after returning initial status, that the addressed device was busy.
CUE (20)		X	X		The 3272 had been addressed while busy, but is now not busy and is free to accept a new command.

*Note 1:* If this asynchronous status is stacked by the channel, an asynchronous CUE could be generated and combined with it before the stacked status is accepted by the channel.

**Figure 1-36 (Part 3 of 3). Asynchronous Status and Sense Conditions — Local**

Column 1 Use this column for: ● Device Selection, ● Specific Poll, ● General Poll, and ● Fixed Return Addresses				
CU or Device Number	EBCDIC I/O Char.	EBCDIC Hex (Note 3)	ASCII I/O Char.	ASCII Hex
0	SP (Note 1)	40	SP	20
1	A	C1	A	41
2	B	C2	B	42
3	C	C3	C	43
4	D	C4	D	44
5	E	C5	E	45
6	F	C6	F	46
7	G	C7	G	47
8	H	C8	H	48
9	I	C9	I	49
10	␣	4A	[	5B
11	.	4B	.	2E
12	<	4C	<	3C
13	(	4D	(	28
14	+	4E	+	2B
15		4F	or !	21
16	&	50	&	26
17	J	D1	J	4A
18	K	D2	K	4B
19	L	D3	L	4C
20	M	D4	M	4D
21	N	D5	N	4E
22	O	D6	O	4F
23	P	D7	P	50
24	Q	D8	Q	51
25	R	D9	R	52
26	!	5A	]	5D
27	\$	5B	\$	24
28	*	5C	*	2A
29	)	5D	)	29
30	;	5E	;	3B
31	␣	5F	␣ or ^	5E

Figure 1-37 (Part 1 of 3). Remote Control Unit and Device Addressing

Column 2 Use this column for:				
<ul style="list-style-type: none"> <li>● 3270 CU Selection Addresses</li> <li>● Test Requests</li> </ul>				
CU Number	EBCDIC I/O Char.	EBCDIC Hex (Note 3)	ASCII I/O Char.	ASCII Hex
0	-	60	-	2D
1	/	61	/	2F
2	S	E2	S	53
3	T	E3	T	54
4	U	E4	U	55
5	V	E5	V	56
6	W	E6	W	57
7	X	E7	X	58
8	Y	E8	Y	59
9	Z	E9	Z	5A
10		6A		7C
11	.	6B	.	2C
12	%	6C	%	25
13	-	6D	-	5F
14	>	6E	>	3E
15	?	6F	?	3F
16	0	F0	0	30
17	1	F1	1	31
18	2	F2	2	32
19	3	F3	3	33
20	4	F4	4	34
21	5	F5	5	35
22	6	F6	6	36
23	7	F7	7	37
24	8	F8	8	38
25	9	F9	9	39
26	:	7A	:	3A
27	#	7B	#	23
28	@	7C	@	40
29	'	7D	'	27
30	=	7E	=	3D
31	" (Note 2)	7F	"	22

Figure 1-37 (Part 2 of 3). Remote Control Unit and Device Addressing

**Examples:**

3271 Addressing			
General Poll CU5	CU Address	EBCDIC	ASCII
		} C5	45
	} C5	45	
Device Address	} 7F	22	
	} 7F	22	
Specific Poll Device 4 on CU5	CU Address	} C5	45
	} C5	45	
Device Address	} C4	44	
	} C4	44	
Select Device 4 on CU5	CU Address	} E5	56
	} E5	56	
Device Address	} C4	44	
	} C4	44	
3275 Addressing			
General Poll CU5	CU Address	EBCDIC	ASCII
		} C5	45
	} C5	45	
Device Address	} 7F	22	
	} 7F	22	
Specific Poll CU5	CU Address	} C5	45
	} C5	45	
Device Address	} 40	20	
	} 40	20	
Select CU5	CU Address	} E5	56
	} E5	56	
Device Address	} 40	20	
	} 40	20	

**Notes:**

1. I/O character address (SP) is always used as the device address when selecting a 3275.
2. I/O character address ("") is used as the device address to specify a General Poll operation.
3. Graphic characters for the United States I/O interface codes are shown. Graphic characters for EBCDIC 4A, 5A, 5B, 7B, 7C, and 7F might differ for particular World Trade I/O interface codes.

**Figure 1-37 (Part 3 of 3). Remote Control Unit and Device Addressing**

Bit No.	Bit Definition
S/S Byte 0:	
0	Use bits 2 through 7 and Figure 1-24 to determine translation.
1	Always a 1.
2	Reserved.
3	Reserved.
4	<p><i>Device Busy (DB)</i> - This bit indicates that the addressed device is busy executing an operation or that a busy detection was previously made by a command or Specific Poll. The device is busy when it is executing an Erase All Unprotected command or a print operation, accepting data from the Operator Identification Card Reader, or performing various keyboard operations (Erase Input, Backtab, and Clear).</p> <p>This bit is set with Operation Check when a Copy command is received which specifies a "busy" device with its "from" address.</p> <p>This bit is set with Unit Specify when a command is addressed to a busy device. This can occur by chaining a command to a Write, Erase/Write, or Copy command which started a Printer or by chaining a command to a Specific Poll addressed to a busy device.</p>
5	<p><i>Unit Specify (US)</i> - This bit is set if any S/S bit is set as a result of a device-detected error or if a command is addressed to a busy device.</p>
6	<p><i>Device End (DE)</i> - This bit indicates that the addressed device has changed from unavailable to available and not ready to ready, or busy to not busy. This bit is included during a Specific or General Poll but is not considered pending status by a Selection Addressing sequence.</p> <p>If a Selection Addressing sequence detects that the addressed device has pending status and also detects one of the above status changes that warrants a Device End, then the Device End bit is set and preserved along with the other pending status, and an RVI response is made.</p>
7	<p><i>Transmission Check (TC)</i> - Not used by the 3271. This bit is set when the 3275 detects a BCC error on the TCU transmission.</p>
S/S Byte 1:	
0	Use bits 2 through 7 and Figure 1-24 to determine translation.
1	Always a 1.
2	<p><i>Command Reject (CR)</i> - This bit is set upon receipt of an invalid 3270 command (or Copy command if this feature is not installed).</p>
3	<p><i>Intervention Required (IR)</i> - This bit is set if:</p> <ul style="list-style-type: none"> <li>● A Copy command contains a "from" address in its data stream which specifies an unavailable device.</li> <li>● A command attempted to start a printer but found it not ready. The printout is suppressed.</li> <li>● The 3271 receives a Selection Addressing sequence or a Specific Poll sequence for a device which is unavailable or which became not ready during a printout. A General Poll sequence does not respond to the unavailable/not ready indication and proceeds to determine the state of the next device.</li> <li>● The 3271 receives a command for a device which the 3271 has logged as unavailable or not ready.</li> </ul>

Figure 1-38 (Part 1 of 2). Remote Status and Sense Byte Definitions

Bit No.	Bit Definition
4	<i>Equipment Check (EC)</i> - This bit indicates a printer character generator or sync check error occurred, the printer became mechanically disabled, or 3271 detected bad parity from the device.
5	<i>Data Check (DC)</i> - This bit indicates the detection of a parity or Cursor check in either the 3271 or a device buffer or in the 3275 buffer, or 3271 detected bad parity from the device.
6	<i>Control Check (CC)</i> - This bit is not used by the 3275. For the 3271, this bit indicates a timeout check. A timeout check occurs when a device fails to respond to 3271 communications within a specified time period or when a device fails to complete an operation within a specified time period.
7	<p><i>Operation Check (OC)</i> - This bit, when set alone, indicates one of the following:</p> <ul style="list-style-type: none"> <li>● Receipt of an illegal buffer address or of an incomplete order sequence on a Write or Erase/Write command.</li> <li>● The device did not receive a CCC or a "from" address on a Copy command.</li> <li>● Receipt of an invalid command sequence. (ESC is not received in the second data character position of the sequence.)</li> <li>● An I/O Interface "overrun" is detected. This occurs during a command when a data byte (Character or Order) is presented to the device by the TCU before the operation required by the previous data byte has been completed.</li> </ul> <p>This bit is set with Control Check, Intervention Required, Data Check, Device Busy, or Data Check with Unit Specify to indicate that the errors that set these sense bits were detected while the 3271 was executing an operation with the "from" device during a Copy command. This bit is set with Unit Specify to indicate that the "from" address on a Copy command specified a device with a "locked" buffer (the device data is secure).</p>

Figure 1-38 (Part 2 of 2). Remote Status and Sense Byte Definitions

Device Response	Command	S/S Explanation
RVI	Selection	<p>Outstanding Status - Pending information from a previous operation with the same device. (If the addressed device is busy, WACK is sent to the TCU instead of RVI, and no S/S bit is set.) <i>Note:</i> A Selection Addressing sequence does not recognize a Device End as pending status. If there is no other pending status, it resets this bit and proceeds with the selection. If the addressed device has other pending status, Device End remains set with it, and the RVI response is made as usual.</p> <p>CC - A timeout check is caused by the addressed device. The operation is tried twice before this bit is set.</p> <p>IR - The addressed device is unavailable.</p> <p>DC, EC (either or both) - The 3271 detects bad parity on data received from the addressed device.</p> <p>DE, EC, US - A character generator or sync check error has occurred, or the printer was mechanically disabled but the condition has been corrected.</p>

Figure 1-39 (Part 1 of 4). Remote Error Status and Sense Responses

Device Response	Command	S/S Explanation
RVI	Selection	<p>DE, IR - The addressed printer is out of paper, its power has been turned off, or its cover is open.</p> <p>DE, IR, EC, US - The addressed printer is mechanically disabled and cannot recover.</p> <p>DE, DC, US - A parity error is detected at the printer.</p> <p>DC, US - A parity check or cursor check is detected by the addressed device on the data it is sending to the control unit.</p>
EOT	Read Commands	<p>CR - Invalid or illegal 3270 command is received at the 3271 or 3275.</p> <p>OC - Invalid command sequence (ESC is not in the second data character position), or data follows the command in the data stream received at the device.</p> <p>DB, US - The addressed device is busy. The command was chained to a Write, Erase/Write, or Copy command which started a print, or it was chained to a Specific Poll.</p> <p>DB, US, DE - The addressed device becomes not busy before a Specific Poll is issued to retrieve the DB, US status.</p> <p>IR - A command is addressed to an unavailable device. (This is not applicable to the 3275.)</p> <p>DC - (1) A cursor check is detected at the 3271 before data transmission starts. The 3271 detects bad parity on data received from the addressed device. The operation is tried twice before this bit is set. No data is transmitted. (2) A parity check is detected by the 3271 before it is transferred to the TCU. A SUB character is substituted for the error character during transmission. When the transmission is completed, the 3271 sends ENQ to indicate an error. When the TCU responds NAK, the 3271 responds EOT. (3) A cursor check is detected by the 3271 during transmission to the TCU. When the transmission is completed, the 3271 sends ENQ to indicate an error. When the TCU responds NAK, the 3271 responds EOT.</p> <p>DC, US - A parity check or cursor check is detected by the addressed device on the data it is sending to the control unit.</p> <p>TC - A BCC error is detected at the 3275.</p>
EOT	Write Commands	<p>CR - An invalid or illegal 3270 command is received.</p> <p>OC - An invalid command sequence (ESC is not in the second data position), an illegal buffer address or an incomplete order sequence is received, or a data byte was sent to the device during the Write command before the operation required by the previous data byte was completed.</p> <p>TC - A BCC error is detected at the 3275.</p>

Figure 1-39 (Part 2 of 4). Remote Error Status and Sense Responses

Device Response	Command	S/S Explanation
EOT	Write Commands	<p>DC - The 3271 detects a parity or cursor check on its buffer during command operation. The 3271 detects bad parity on data received from the addressed device. The operation is tried twice before this bit is set.</p> <p>DC, US - The device detects a parity or cursor check on its buffer during the command operation.</p> <p>CC - The device fails to complete an operation or respond to the 3271 in a certain time (timeout check).</p> <p>DB, US - The addressed device is busy. The message is accepted but not stored in the 3271 or 3275 buffer. The command is aborted.</p> <p>DE, DB, US - The addressed device becomes not busy before a specific poll is issued to retrieve the DB, US status (described above).</p>
EOT	Copy Command	<p>CC, OC - The "from" device fails to complete an operation or respond to the 3271 in a certain time (timeout check).</p> <p>DB, OC - The "from" device is busy. (The device is busy executing an operation, a printout, reading data from the Operator Identification Card Reader, or performing a keyboard operation.) The Copy command is aborted.</p> <p>IR, OC - The device is not available.</p> <p>OC, US - The device has a locked buffer.</p> <p>OC - The data stream contains other than two bytes (the CCC and the "from" address). The command is aborted.</p> <p>DC, OC - The 3271 detects a parity check on the data transferred from the "from" device.</p> <p>DC, OC, US - Set when "from" device detects an internal parity or cursor check.</p> <p>DB, US - The addressed "to" device is busy.</p> <p>DB, US, OC - The addressed "to" device is also specified as the "from" device and is busy.</p> <p>DB, US, OC, DE - The addressed device becomes not busy before a specific poll is issued to retrieve the DB, US, OC status (described above).</p>
EOT	Write, Erase/Write, Copy Commands	<p>IR - Addressed device is not available, or addressed printer is not ready.</p> <p>IR, EC, US - A command attempted to start a print operation, but the printer CARRIAGE MOTOR POWER switch (a CE service switch) is turned off.</p>
EOT	Erase All Unprotected Command  Specific and General Poll	<p>OC - One or more data bytes followed the command (buffer overrun).</p> <p>DE, IR, EC, US - An unrecoverable mechanical failure is detected at the printer.</p> <p>DE, EC, US - A character generator or sync check error or a mechanical failure is detected at the printer but then recovered from.</p>

Figure 1-39 (Part 3 of 4). Remote Error Status and Sense Responses

Device Response	Command	S/S Explanation
EOT	Specific and General Poll	<p>DC, US - A parity check or cursor check is detected by the addressed device on the data it is sending to the control unit.</p> <p>DC - (1) A parity error is detected by the 3271 on data to be transferred to the TCU. A SUB character is substituted for the error character during transmission. The transmission is completed, and ENQ is sent by the 3271. When the TCU responds NAK, the 3271 responds EOT. (2) A cursor check is detected at the 3271 before data transmission starts. (No data is transmitted.) (3) A cursor check is detected by the 3271 during transmission to the TCU. The transmission is completed, and the 3271 sends ENQ. When the TCU responds NAK, the 3271 responds EOT.</p> <p>DC, EC (either or both) - The 3271 detects a parity check on data received from the device.</p> <p>DE - The poll finds a device (1), previously recorded as busy, now not busy or, (2), previously recorded as unavailable or not ready, now available and ready. (The 3271 record is updated.) <i>Note:</i> When 3271 power is turned on, the DE bit is set for every available and ready device that is attached.</p> <p>IR, DE - The poll finds a device, previously recorded as ready, available, and busy, now not ready and not busy, or the printer went not ready during a printout. (The 3271 record is updated.)</p> <p>DC, US, DE - A parity error is detected at printer.</p> <p>CC (Specific Poll only) - The poll finds a device, previously recorded as unavailable, still unavailable (time-out check).</p> <p>DC, DE - 3275 (only) detects an internal parity or cursor check on its buffer when the printer goes "Not Busy".</p> <p>IR, EC, DE (3275 only) - The printer CARRIAGE MOTOR POWER switch (a CE service switch) is turned off, or a mechanical "hang" condition is detected.</p> <p>EC, DE (3275 only) - Character generator readout error.</p>
	Specific Poll	<p>CC - The poll finds a device, previously recorded as available and ready, now unavailable (timeout check). (The 3271 record is updated.)</p> <p>DB - The addressed device is busy.</p>
NAK	Read and Write Commands	<p>NAK is transmitted by the 3271 when it detects a Block Control Character (BCC) error on the TCU transmission. A BCC error has priority over all other detectable error conditions. If, for example, a BCC error and a parity error are detected during the same command transmission, the parity error condition is reset, and a NAK response is set by the 3271.</p>

Figure 1-39 (Part 4 of 4). Remote Error Status and Sense Responses

Sense/ Status Bits	Detected during 3270 Operation						Transmitted in Response to:	
	Hex		Selection Addressing Seq	Specific Poll Seq	General Poll Seq	A 3270 Command	Specific Poll	General Poll
	EBCDIC	ASCII						
CR	40	60	20	2D			D, P	
OC	40	C1	20	41			D, P	
OC, US	C4	C1	44	41			D, P	
CC	40	C2	20	42	D, P	D, P	D, P	
CC, OC	40	C3	20	43			D, P	
IR	40	50	20	26	D, P	D, P	D, P	
IR, OC	40	D1	20	4A			D, P	
DC	40	C4	20	44	D, P	D, P	D, P	D, P, I
EC	40	C8	20	48	D, P	D, P	D, P	D, P
DC, EC	40	4C	20	3C	D, P	D, P	D, P	D, P
DC, OC	40	C5	20	45			D, P	
DC, US	C4	C4	44	44	D, P	D, P	D, P	D, P
DC, OC, US	C4	C5	44	45			D, P	
DC, DE	C2	C4	42	44		P		P
DC, US, DE	C6	C4	46	44		P	P	P
IR, DE	C2	50	42	26		P	P	P
IR, EC, DE	C2	D8	42	51		P	P	P
EC, DE	C2	C8	42	48		P	P	P
EC, US, DE	C6	C8	46	48		P	P	P
IR, EC, US								
DE	C6	D8	46	51		P	P	P
DB	C8	40	48	20	D, P		D, P	
DB, DE**	4A	40	54	20			D	
DB, US*	4C	40	3C	20			D, P	
DB, US, DE	4E	40	2B	20			D, P	
OC, DB*	C8	C1	48	41			D, P	
TC	C1	40	41	20			D	
TC, OC	C1	C1	41	41			D	
TC, CR	C1	60	41	2D			D	
TC, DC	C1	C4	41	44			D	
DE	C2	40	42	20	D, P	D, P	D, P	D, P
IR, EC, US	C4	D8	44	51			P	

Note: The 3271-attached device errors that are detected asynchronously do not cause a 3271 Sense bit to set until the device is polled for status during a Selection Addressing, Specific Poll, or General Poll sequence. Those error S/S bit combinations that contain DE were detected during a printout.

- \*The DB, US, and OC S/S bits will be combined if a Copy command is addressed to a busy "to" device and the command also specifies the "from" device the same as the "to" device.
- \*\*The DB and DE S/S bits can occur together in response to a Specific Poll to a formatted 3277 if the operator has performed Backtab or Erase Input operations in rapid succession. Ignore Device End and treat as Device Busy only.

#### Legend

- D — Display (3277 or 3275)
- P — Printer
- I — 3275 Only

Figure 1-40. Remote Status and Sense Conditions

## INDICATORS AND CONTROLS

The indicators and controls associated with each 3270 unit are listed in Figure 1-41 and are described below:

**OFF-PUSH:** This triple-function concentric switch/control is used to control the application of power to the unit, and also to control the brightness (outer knob) and contrast (inner knob) of the displayed image.

**BIT RATE:** This two-position toggle switch, added by the Dial feature, allows the 3275 model 1 or 2 operator to select a transmission rate of 600 or 1200 bps.

**DISCONNECT:** This momentary-contact toggle switch, added to the 3275 model 1 or 2 by the Dial feature, is used by the 3275 operator when terminating a call.

**INSERT MODE:** This indicator is turned on by the keyboard INS MODE key to show that the unit is in Insert Mode of operation. It is turned off by the keyboard RESET key.

**INPUT INHIBITED:** When lighted, this indicator shows that manual input to the unit from the keyboard, Selector Pen, or Operator Identification Card Reader is inhibited.

It is turned on by:

1. Operation of any program attention key.
2. A selector-pen-attention operation that caused an I/O interruption to occur.
3. An operator-identification-card-reader operation that caused an I/O interruption to occur.
4. Turning the Security Key Lock to the OFF position if the Security Key Lock feature is installed.
5. Initiation of a printout at an unbuffered printer attached to the 3275 Display Station.
6. A system-initiated I/O operation addressed to that unit.
7. Operation of any alphameric key, the DUP, FIELD MARK, ERASE EOF, or DEL keys when the cursor is in a protected field.
8. Operation of any alphameric key not included in the numeric key grouping when the cursor is in a numeric field, without simultaneously operating either the ALPHA or NUMERIC shift key, when the Numeric Lock special feature is installed.
9. Detection of a parity or Cursor Check in the device buffer.

It is turned off by:

1. Receipt and execution of a WCC with the Keyboard Restore bit set.
2. Receipt and execution of an Erase All Unprotected command.
3. Turning the Security Key Lock to the On position (if it was turned on because the Security Key Lock was in the Off position).
4. Operation of the keyboard RESET key, with the following exceptions:
  - a. The device is selected and executing a command from the control unit.
  - b. The display station is in the process of reading a magnetic card from the Operator Identification Card Reader.
  - c. A printout is in process at the attached 3284 Printer Model 3.
  - d. A parity or Cursor Check has been detected.
5. Termination of an unbuffered printer printout (if it was turned on because an unbuffered printer printout was initiated).
6. Correction of a parity or Cursor Check condition and resetting of the error status by a Write or Erase/Write command addressed to that device.

**SYSTEM AVAILABLE (3275, models 1 and 2, 3277), Sys Avl (3288):** When lighted, this indicator shows that the unit has had successful communication with the system and is available to accept an operator-initiated transmission to the system.

It is turned on by:

1. Successful completion of a Write, Erase/Write, Erase All Unprotected, Copy, Read Modified, or Read Buffer command, in local or remote operation.
2. On a 3275 (models 1 and 2), receipt of an ACK from the TCU in response to an ETX at the completion of a General or Specific Poll sequence.

Indicator or Control	3270 Unit					
	3277	3275	3272	3271	3284, 3286	3288
OFF-PUSH (Sw, Ctl)	X	X				
BIT RATE (Sw)		D				
DISCONNECT (Sw)		D				
INSERT MODE (Ind)	X	X				
INPUT INHIBITED (Ind)	X	X				
SYSTEM AVAILABLE (Ind)	X	X				X
Sys Avl (Ind)						X
SYSTEM READY (Ind)		X		X		
SYNC SEARCH (Ind)		X		X		
SELECTED (Ind)		X		X		
FLAG DETECT		S		S		
CU ACTIVE		S		S		
OFF HOOK (Ind)		D				
TRANSMIT (Ind)		X		X		
STATUS (Ind)		X		X		
POWER ON LOCAL MODE (Sw)			X			
POWER OFF LOCAL MODE (Sw)			X			
MAIN LINE ON/OFF (Sw)			X			
LOC/REM (Sw)			X			
ON LINE/OFF LINE (Sw)			X			
I/O INTF DSBLD (Sw)			X			
POWER ON/OFF (Sw)				X	X	X
Power On (1)/Power off (0) (Sw)						X
Carriage Restore (Pb)						X
Start Test (Sw)						X
VFC Selector (Sw)						X
POWER ON (Ind)			X			
Ready (Ind)						X
Ops Chk (Ind)						X
Address I.D. (Label)	X	X			X	X

Key: Sw - Switch                      X - Basic  
 Ctl - Control                         D - Dial Feature  
 Ind - Indicator                        S - SDLC

**Figure 1-41. Indicators and Controls**

It is turned off by:

1. Any operator-generated I/O interrupt.
2. A parity or cursor check and resulting I/O interrupt.
3. Turning the Security Key Lock to the Off position.

**SYSTEM READY:** When lighted, this indicator shows that the Data Set carrier is on and that the TCU is online. With the Dial feature installed, this indicator lights when a transmission is first sent or received and extinguishes when a disconnect sequence is sent or received.

**SYNC SEARCH (3271 and 3275 models 1 and 2 only):** When lighted, this indicator shows that the unit is attempting to establish line synchronization.

**SELECTED (3271 and 3275 models 1 and 2 only):** When lighted, this indicator shows that the unit has been selected; i.e., it is in the process of executing a command or a chain of commands.

**CU ACTIVE (3271 and 3275 models 11 and 12 only):** The indicator lights after selection, and remains set until the operation is complete.

**FLAG DETECT (3271 and 3275 models 11 and 12 only):** This indicator lights when a valid flag character (7E) is received.

**OFF HOOK/AUTO ANSWER:** This indicator replaces the SELECTED indicator when the IBM Line Adapter or external modem with Auto Answer feature is installed. When lit, it indicates that a communications link to the 3275 (models 1 and 2) is active (that is, the data access arrangement is "off hook"). When the Auto Answer feature is not installed, the OFF HOOK/AUTO ANSWER indicator is always lit during unit operation.

**TRANSMIT:** When lighted, this indicator shows that the unit is transmitting to the TCU.

**STATUS:** When lighted, this indicator shows that an error status condition exists within the unit.

**POWER ON LOCAL MODE:** This momentary-contact switch is used to turn on dc power for a 3272.

**POWER OFF LOCAL MODE:** This momentary-contact switch is used to turn off dc power for a 3272.

**MAIN LINE ON/OFF:** This two-position toggle switch is used to turn on and turn off ac power for the 3272.

**LOC/REM:** This two-position rotary switch on the 3272, when placed in the REM (remote) position, gives control of the power supply activation to the CPU to which the control unit is attached. When placed in the LOC (local) position, power is controlled at the 3272 by using the POWER ON LOCAL MODE and POWER OFF LOCAL MODE switches.

**ON LINE/OFF LINE:** This two-position toggle switch, when placed in the ON LINE position (the operating position) connects the 3272 to the channel interface.

**I/O INTF DSBLD:** This indicator lights when the ON LINE/OFF LINE switch on the 3272 is in the OFF LINE position.

**POWER ON:** When lighted, this indicator shows that power has been turned on for a 3272.

**POWER ON/OFF:** This two-position toggle switch is used to turn on and turn off power for 3271 control units and all printers.

**READY:** When lighted, this indicator shows that the 3284, 3286, or 3288 Printer is ready to receive transmissions from the control unit. It is turned on after a successful power-on sequence, when the belt is up to speed and the printer is ready to print data.

It is turned off by:

1. Open machine covers.
2. Open print unit.
3. Running out of forms.
4. A paper motion failure (forms jam, torn forms, or missing feed holes).
5. An overheated printer mechanism.
6. A hardware failure requiring a repair action.

**Ops Chk:** When blinking, this indicator shows that the 3288 Line Printer Not Ready condition (shown by the Ready indicator being off) can be corrected by the operator.

It is turned on by:

1. Open machine covers.
2. Open print unit.
3. Running out of forms.
4. A paper motion failure.
5. The TEST switch (on test switch panel) in other than the ON LN (On Line) position.

It is turned off when the condition that caused it to light is corrected.

**Address Identification:** Provision is made on each display station and printer to identify both the physical (hexadecimal) and symbolic addresses assigned to that unit at installation time.

**VFC Selector:** The VFC Selector switches on the 3288 Line Printer are set (00-99) by the operator to determine the number of lines skipped in a VFC operation.

**Carriage Restore:** The Carriage Restore pushbutton on the 3288 Line Printer advances the forms to a predetermined print line established by the initial forms positioning and the settings of the VFC selector switches.

**Power On/Power Off (Coded I and O):** This two-position rocker switch is used to control power to the 3288 Line Printer.

**Start Test:** This switch on the 3288 is used in conjunction with the test switches located on the test switch panel under the top cover to initiate offline test printouts.

# SEQUENCES AND RESPONSES

Figures 1-42 through 1-50 are sequence and response diagrams.

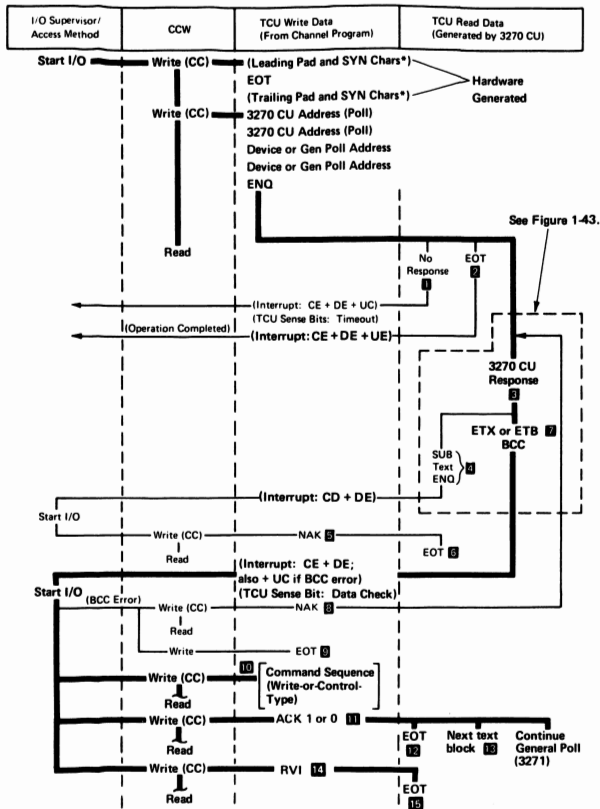

Figure 1-42 (Part 1 of 2). General Poll and Specific Poll, Sequence/Response Diagram

**Notes:**

- 1** The 3270 CU will fail to respond to the addressing or polling sequence, causing a TCU timeout, for any of the following reasons:
  - o The 3270 CU is "unavailable" (has power off, is "offline", or is not attached).
  - o The 3275 is "unavailable" to a Specific Poll sequence because the Security Lock is in the "off" position.
  - o Any character in the polling sequence is invalid.
  - o The characters in the polling sequence are out of order.
  - o The polling sequence is incomplete (less than seven characters).
  - o The 3270 CU address is incorrect in the write data stream.
  - o The addressed 3270 CU was left selected from the previous transmission.
- 2** There is no I/O pending nor pending status. For General Poll, the CU sends EOT only after polling all devices.
- 3** The device response is a function of the kind of device and its status. Types of responses include: Text, Status, and Test Request messages. (Refer to Figure 1-43).

3271: For General Poll, the search for a response starts at some random device address and continues sequentially (as long as ACKs are received in response to text transmissions) until all devices are given the opportunity to respond.
- 4** Upon detection of an internal parity check or a cursor check, the 3270 CU (1) substitutes the SUB character for the character in error, (2) records Data Check status, and (3) transmits an ENQ in place of ETX (or ETB) and BCC at the end of the text block. The internal 3271/device polling is stopped.
- 5** Mandatory program response to a text block terminated in ENQ.
- 6** Terminates the operation. The nature of the error (parity or cursor check) does not warrant a retry. This response indicates that status and sense information is stored and that internal 3271/device polling is stopped. The status retrieval information included in Figure 1-16, Note 2, applies.
- 7** ETB is used to frame each block of a blocked text message, except the last block. ETX is used to frame the last block of a blocked text message.
- 8** BCC error has been detected. The program issues NAK to cause the 3270 CU to repeat its last transmission.
- 9** Response issued by the program to terminate the operation if the TCU is unsuccessful in receiving a valid BCC following "n" attempts by the 3270 CU to transmit the message. This response does not cause the 3270 CU to reset its sense/status information. Therefore, the same status message will be transmitted if a Specific Poll is immediately issued to the same device.
- 10** This transmission must be a write or control-type command sequence (described in Figure 1-45). A read-type command would violate BSC standards on Limited Conversational mode.

3271: For General Poll, this transmission stops the 3271/device polling operation. The General Poll must be reinitiated to ensure receipt of all pending device messages.
- 11** Positive acknowledgment. The text block has been successfully received by the TCU. The program issues ACK 1 in response to the first and all odd-numbered text blocks and issues ACK 0 in response to the second and all even-numbered text blocks. This response to a text block terminated in ETX turns on the 3275 SYSTEM AVAILABLE indicator.
- 12** Normal termination of a Specific Poll.

3271: Normal termination of a General Poll.  
3275: No additional response is generated by the 3275 at the end of a General Poll.
- 13** The second and all succeeding text blocks are framed as the first except they do not include the 3270 CU/device address sequence.
- 14** RVI to terminate polling sequence.
- 15** Termination of polling sequence on receipt of RVI.

**LEGEND:**

(CC) = Chain Command (CC) Flag in CCW is set to 1.

(Interrupt) = TCU-generated interrupt (CE = Channel End, DE = Device End, UE = Unit Exception, UC = Unit Check).

- 1** Reversed numbers refer to notes.

\*Only the critical framing characters (sync pattern and pad) are shown. All other framing characters are also hardware-generated as required. See SL *General Information - Binary Synchronous Communications*, GA27-3004, for a complete description.

**Figure 1-42 (Part 2 of 2). General Poll and Specific Poll, Sequence/Response Diagram**

(Note: This figure is referenced in Figures 1-42 and 1-46.)

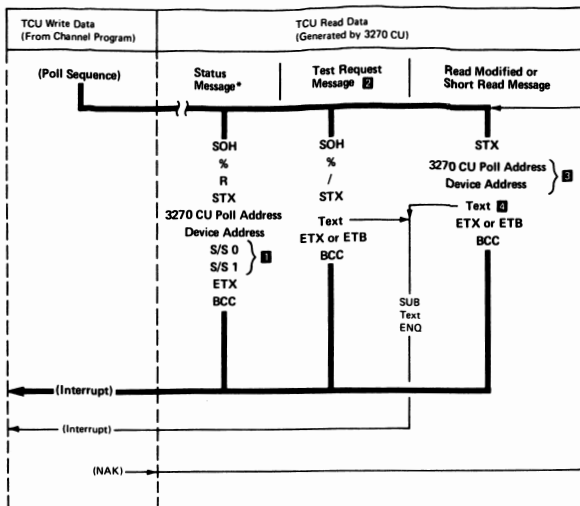

\*Response to General Poll or Specific Poll only (not program-generated Read Modified command)

Figure 1-43 (Part 1 of 2). 3270 CU Message Response to Polling or Read Modified Command

*Notes:*

- 1** A status message response is issued to a General or Specific Poll if (1) the 3270 CU has pending status (General Poll ignores Device Busy and device "unavailable" and, if 3271, continues polling of next device), or (2) if error status develops during execution of the poll. Status and Sense bit assignments are described in Figure 1-38.
- 2** A Test Request Message response is issued to a General or Specific Poll if a TEST REQ key is pressed at the keyboard of a polled 3275 or 3277.
- 3** This address is included only in the first block of a blocked text message.
- 4** The text portion of this message is the result of either a read-modified or short-read operation by the 3270 CU. Figure 1-26 lists each operator action and the resulting read operation that will be performed. The read operations and the resulting data are described under "Read Modified Command" in the section entitled "Commands and Orders".

**LEGEND:**

(Interrupt) = TCU-generated interrupt.

- 1** Reversed numbers refer to notes.

**Figure 1-43 (Part 2 of 2). 3270 CU Message Response to Polling or Read Modified Command**

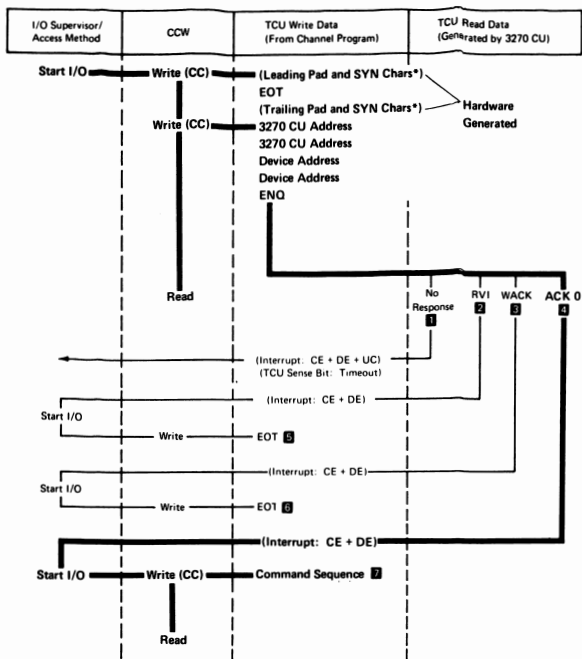

\*Only the critical framing characters (sync pattern and pad) are shown. All other framing characters are also hardware-generated as required. See *SL General Information - Binary Synchronous Communications, GA27-3004*, for a complete description.

Figure 1-44 (Part 1 of 2). Selection Addressing, Sequence/Response Diagram

*Notes:*

- 1** The 3270 CU will fail to respond to the addressing or polling sequence causing a TCU timeout, for any of the following reasons:
  - The 3271 is "unavailable" (has power off, is "offline", or is not attached).
  - The 3275 is "unavailable" (is not attached, has power down, or has the Security Lock in the "off" position).
  - Any character in the polling sequence is invalid.
  - The characters in the polling sequence are out of order.
  - The polling sequence is incomplete (less than seven characters).
  - The 3270 CU address is incorrect in the write data stream.
  - The addressed 3270 CU was left selected from the previous transmission.
- 2** 3271: The addressed device has pending status (excluding Device Busy and Device End) or is unavailable, the device-to-3271 buffer transfer was unsuccessful, the 3271 detected an internal parity or cursor check, or the addressed printer became "not ready" (out of paper, unrecoverable "hang", power off, or cover open). The S/S information is stored in the 3271, and the internal 3271/device polling is stopped.

3275: The 3275 has pending status, excluding Device Busy and Device End.
- 3** The addressed 3271 device or the 3275, including the 3284-3 Printer, is busy. No S/S information is stored. An RVI response takes precedence over a WACK response.
- 4** The address has been successfully received, no status is pending, and, in the case of the 3271, the device-to-3271 buffer transfer is successfully completed.
- 5** Termination of attempted addressing sequence:

3271: Availability of valid status and sense information cannot be ensured unless a Specific Poll is issued to the responding device as the next addressing sequence issued to this 3271. Successful completion of a Specific Poll addressed to the responding device, a device selection addressed to any other device on the same 3271, or a General Poll addressed to the same 3271, is required to start the internal 3271 device polling operation.

3275: A Specific Poll to the 3275 retrieves the status existing at the time the RVI response was made.
- 6** Termination of attempted addressing sequence.
- 7** Refer to Figure 1-45 or 1-47 for the desired command sequence.

**LEGEND:**

(CC) = Chain Command (CC) Flag in CCW is set to 1.

(Interrupt) = TCU-Generated interrupt (CE = Channel End, DE = Device End, and UC = Unit Check)

- 1** Reversed numbers refer to notes.

**Figure 1-44 (Part 2 of 2). Selection Addressing,  
Sequence/Response Diagram**

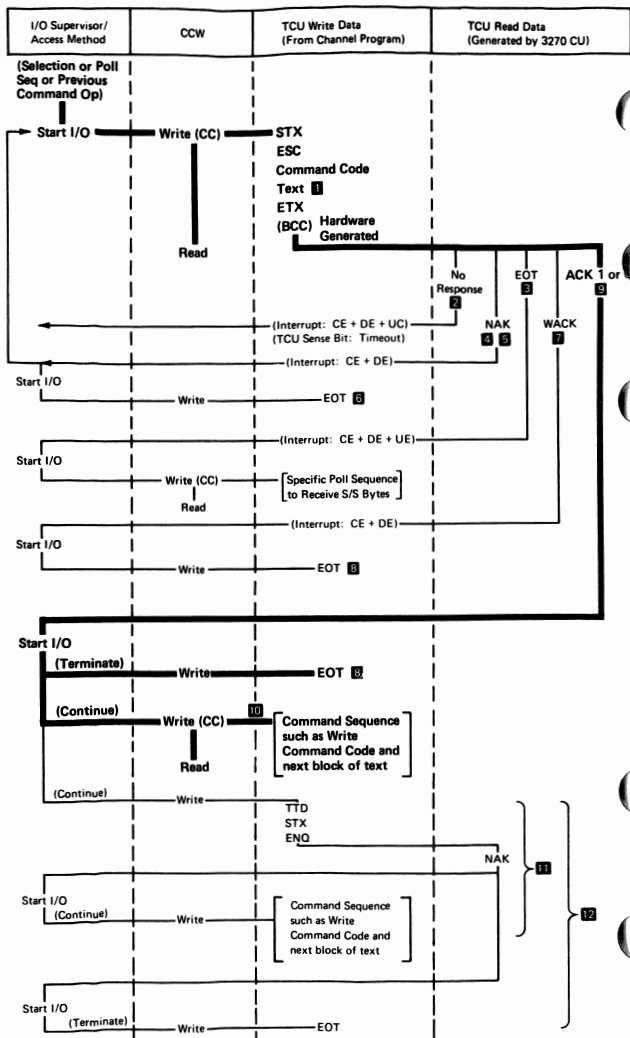

Figure 1-45 (Part 1 of 2). Write-Type and Control-Type Commands, Sequence/Response Diagram

Notes:

- 1 No text is transmitted on an EAU command transmission.
- 2 Command transmission was not successfully received because of invalid framing (STX missing). Causes timeout at TCU.
- 3 3271: The 3271 is unable to perform the operation indicated in the command transmission because of a busy/unavailable/not ready device or one of the following 3271-detected check conditions:
  - a. receipt of an illegal command/order sequence,
  - b. failure to decode a valid command.
  - c. an I/O interface "overrun",
  - d. a parity/cursor check,
  - e. an illegal buffer address, or
  - f. a locked buffer.

In the case of the Copy command: Copy feature is not installed, "from" device is busy or has locked buffer, or CCC is missing.

The EOT response to a command transmission indicates that status information is stored in the 3271 and that internal 3271/device polling is stopped. To ensure retrieval of valid status, the program must issue a Specific Poll (addressing the device that was selected when EOT was generated) as the next addressing sequence to this 3271. Successful completion of a Specific Poll addressed to the responding device, a device selection addressed to any other device on the same 3271, or a General Poll addressed to the same 3271, is required to restart the internal 3271/device polling operation.

- 3275: The 3275 is unable to perform the operation indicated in the command transmission because of (1) a BCC error, (2) a busy 3275 (including the attached 3284-3 Printer), or (3) a 3275-detected check condition (receipt of an illegal command/order sequence, failure to decode a valid command, an I/O interface "overrun", a parity/cursor check, or missing ETX). A Specific Poll to the 3275 retrieves the status existing at the time the EOT response was made.

- 4 3271: If a transmission problem causes both a 3271-detected check condition and a BCC error, the BCC error takes precedence over all other check conditions, and a NAK is transmitted to the TCU.
- 5 3271: BCC error or missing ETX has been detected. The NAK response requests the program to repeat its last transmission.

Note: The 3275 responds with EOT if it detects a BCC error or a missing ETX.

- 6 Response issued by the program to terminate the operation if the 3271 is unsuccessful in receiving a valid BCC following "n" attempts by the program to transmit the message.
- 7 If the Start Printer bit is set in the WCC or CCC, a WACK response indicates that the text transmission was successfully received (and, if 3271, that the 3271-to-device buffer transfer was successfully completed) but that the printer is now busy and an additional chained command cannot be accepted.

If any of the conditions cited in Note 3 prevail, the EOT response takes precedence over the WACK response.

- 8 Normal termination of the operation by the program.
- 9 Command execution has been successfully completed and, in the case of the 3271, the 3271-to-device buffer transfer is successfully completed.
- 10 Repeat the operation shown in this figure or in Figure 1-46 for the next command sequence.
- 11 Example of a Temporary Text Delay (TTD) sequence.
- 12 Example of terminating an operation using TTD (a forward abort sequence).

LEGEND:

(CC) = Chain Command (CC) Flag in CCW is set to 1.

(Interrupt) = TCU-generated interruption (CE = Channel End, DE = Device End, UE = Unit Exception, UC = Unit Check).

- 1 Reversed numbers refer to notes.

Figure 1-45 (Part 2 of 2). Write-Type and Control-Type Commands, Sequence/Response Diagram

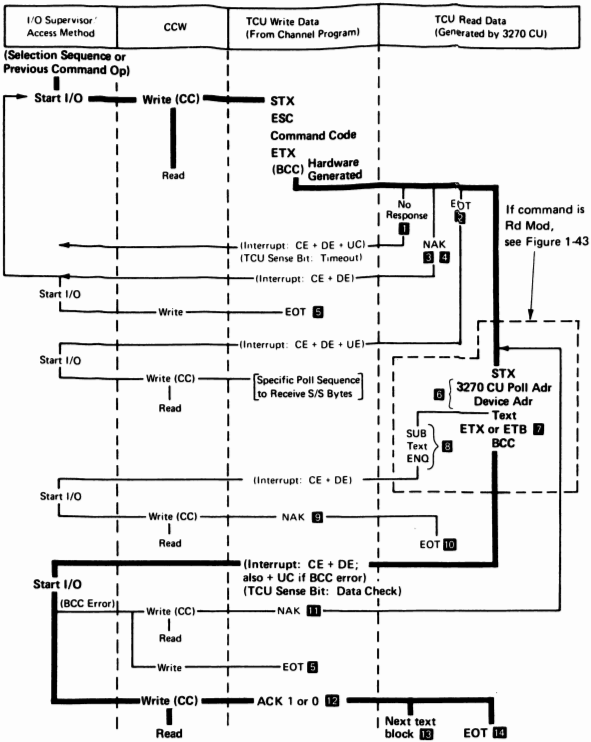

Figure 1-46 (Part 1 of 2). Read-Type Command, Sequence/Response Diagram

**Notes:**

- 1** Command transmission was not successfully received because of invalid framing (STX missing). Causes timeout at TCU.
- 2** 3271: The 3271 is unable to perform the operation indicated in the command transmission because of a busy/unavailable/not ready device or a 3271-detected check condition (receipt of an illegal command/order sequence, failure to decode a valid command, or an I/O interface "overrun"). The EOT response to a command transmission indicates that status information is stored in the 3271 and that internal 3271/device polling is stopped. To ensure retrieval of valid status, a Specific Poll must be issued to the device-responding EOT as the next addressing sequence issued to this 3271. Restarting of the internal 3271 polling operation requires the successful completion of a Specific Poll addressed to the responding device, a device selection addressed to any other device on the same 3271, or a General Poll addressed to the same 3271.  
  
3275: The 3275 is unable to perform the operation indicated in the command transmission because it (1) has detected a BCC error, (2) is busy (includes an attached 3284-3 Printer), (3) has detected a check condition (has received an illegal command/order sequence, has failed to decode a valid command, or has detected an I/O interface "overrun" or a missing ETX). A Specific Poll to the 3275 retrieves the status existing at the time the EOT response was made.
- 3** 3271: If a transmission problem causes both a 3271-detected check condition and a BCC error, the BCC error takes precedence over all other check conditions, and a NAK is transmitted to the TCU.
- 4** 3271: BCC error or missing ETX has been detected. The NAK response requests the program to repeat its last transmission.  
  
*Note:* The 3275 responds with EOT if it detects a BCC error or a missing ETX.
- 5** Response issued by the program to terminate the operation if the 3271 is unsuccessful in receiving a valid BCC following "n" attempts by the program to transmit the message.
- 6** This address sequence is included only in the first block of a blocked text message.
- 7** ETB is used to frame each block of a blocked text message, except for the last block. ETX is used to frame the last block of a blocked text message.
- 8** Upon detection of an internal parity check, the 3270 CU automatically substitutes the SUB character for the character in error. If a parity or cursor check is detected, ENQ is transmitted in place of ETX (or ETB) and BCC at the end of the text block and appropriate status and sense information is stored; also, internal 3271/device polling is stopped.
- 9** Mandatory program response to a text block terminated in ENQ.
- 10** Response to terminate the operation. The nature of the error (parity or cursor check) does not warrant a retry. This response indicates that appropriate status and sense information is stored and that internal 3271/device polling is stopped. The status retrieval information included in Note 2 applies.
- 11** BCC error has been detected. The program issues NAK to cause the 3270 CU to repeat its last transmission.
- 12** Positive acknowledgment. The text block has been successfully received by the TCU. The program issues ACK 1 in response to the first and all odd-numbered text blocks and issues ACK 0 in response to the second and all even-numbered text blocks. This response to a text block terminated in ETX turns on the device SYSTEM AVAILABLE indicator.
- 13** The second and all succeeding text blocks are framed as the first except that they do not include the 3270 CU/device address sequence.
- 14** Normal termination of the operation following transmission of the last text block.

**LEGEND:**

(CC) = Chain Command (CC) Flag in CCW is set to 1.

(Interrupt) = TCU-generated interrupt (CE = Channel End, DE = Device End, UE = Unit Exception, UC = Unit Check)

- 1** Reversed numbers refer to notes.

**Figure 1-46 (Part 2 of 2). Read-Type Command, Sequence/Response Diagram**

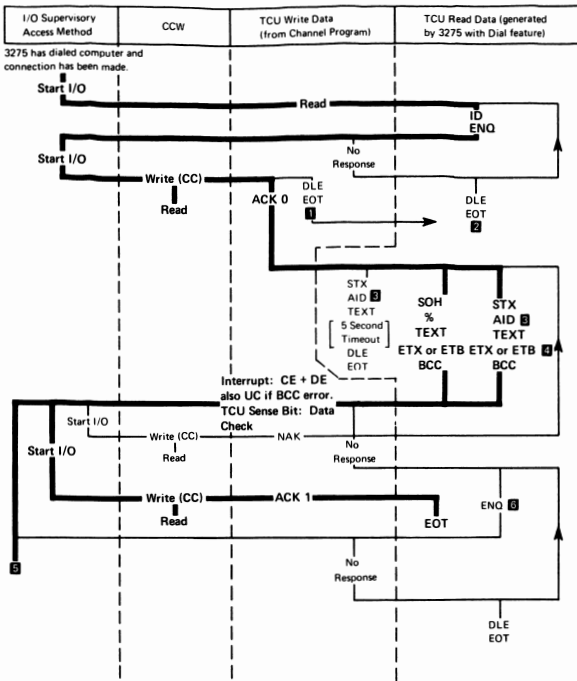

Figure 1-47 (Part 1 of 2). 3275-Initiated Transmission, Sequence/Response Diagram – Dial Feature

*Notes:*

- 1** Upon correct reception of an invalid terminal ID, the computer disconnects. The TCU may optionally send DLE EOT before disconnecting. This is defined in the BSC rules as an "unusual termination".
- 2** The 3275 retries three times. When the number of retries is exhausted, the 3275 sends DLE EOT.
- 3** AID indicates which situation caused attention.
- 4** ETB is used to frame each block of a blocked text message, except the last block. ETX is used to frame the last block of a blocked text message.
- 5** The remainder of this sequence/response diagram is the same as that for a General or Specific Poll, as shown in Figure 1-42.
- 6** The 3275 as the master station solicits a response by sending ENQ. After the number of retries is exhausted, the 3275 acts as described in Note 2.

LEGEND:

- 1** Reversed numbers refer to notes.

**Figure 1-47 (Part 2 of 2). 3275-Initiated Transmission, Sequence/Response Diagram – Dial Feature**

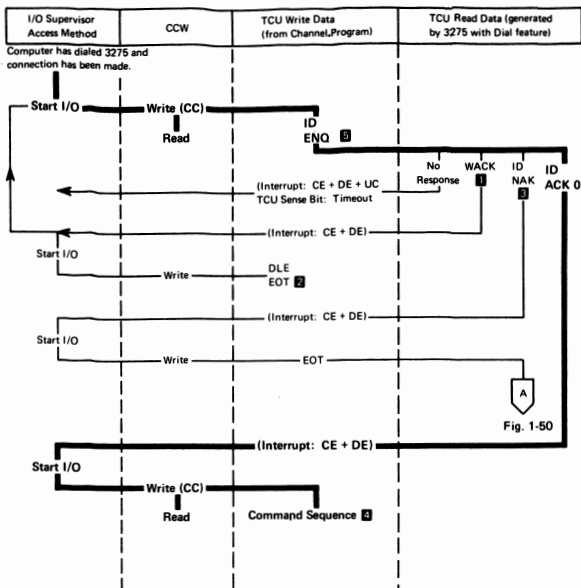

Figure 1-48 (Part 1 of 2). TCU-Initiated Transmission, Sequence/Response Diagram – Dial Feature

*Notes:*

- 1** The 3275 is not ready to receive due to a printer, keyboard, or card reader operation.
- 2** The TCU should transmit DLE EOT before disconnecting. The 3275 with the Auto Answer feature will recognize DLE EOT and automatically disconnect.
- 3** The 3275 has status pending other than a busy printer and is not ready to receive. The 3275 monitors for EOT and prepares transmission of a status message.
- 4** Refer to Figure 1-45 or 1-46 for the desired command sequence.
- 5** Not decoded or used by the 3275.

LEGEND:

- 1** Reversed numbers refer to notes.

**Figure 1-48 (Part 2 of 2). TCU-Initiated Transmission, Sequence/Response Diagram – Dial Feature**

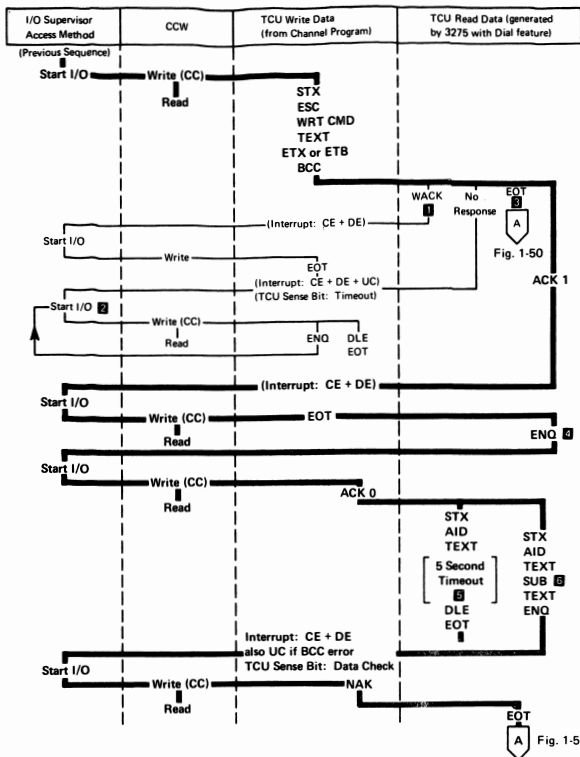

Figure 1-49 (Part 1 of 2). Example of Maintained Connection, Sequence/Response Diagram – Dial Feature

*Notes:*

- 1** Positive acknowledgment, when the printer bit has been set in the Write Control Word (WCC) included with the Write command issued to a 3275 with attached printer. The printer is now busy.
- 2** The 3275 as the master station solicits a response by sending ENQ. After three retries, the 3275 that is equipped with the Auto Answer feature sends DLE EOT and disconnects automatically. The 3275 that is not so equipped sends DLE EOT. The operator should then manually disconnect.
- 3** The 3275 aborts because it is unable to receive or to execute the command. This condition causes status to be set and the transmission of a status message to be prepared. This situation could have been caused as the result of a command in a chain following a start-print operation or as the result of a BCC error.
- 4** The connection is still maintained. The 3275 has prepared another text message and bids for the line.
- 5** Here, it is assumed that the 3275 cannot complete transmission because of a malfunction other than an internal parity check. A 5-second transmission timeout becomes effective, the uncompleted text transmission is terminated by DLE EOT, and, with Auto Answer installed, the telephone is automatically hung up.
- 6** Here, it is assumed that an internal parity error has been detected and the SUB character has been substituted for the character in error. The text block is terminated by ENQ. The mandatory response is NAK. In this situation, the 3275 is preparing for the transmission of a status message.

LEGEND:

- 1** Reversed numbers refer to notes.

**Figure 1-49 (Part 2 of 2). Example of Maintained Connection, Sequence/Response Diagram — Dial Feature**

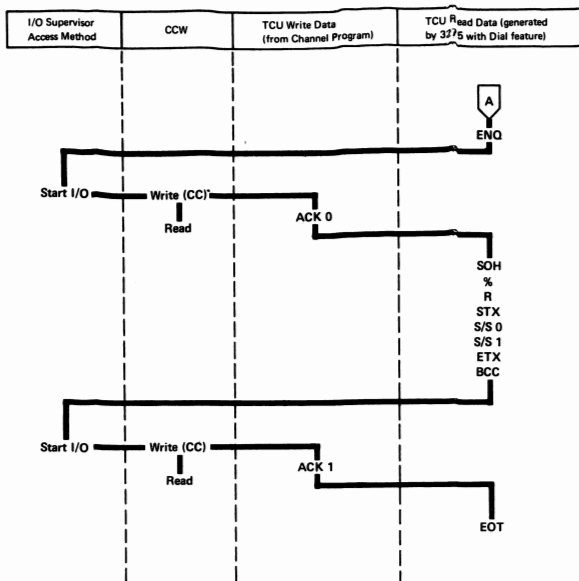

Figure 1-50. Status Message Transmission with Dial Feature, Sequence/Response Diagram

## IR FUNCTIONAL UNIT CODE GUIDE

### 3271/3272/3275/3277/3284/3286

Following is an alphabetic list of major units.

#### All Machines

000	Base
870	Customer Responsibility
960	Error Indicated/Trouble Not Isolated
601	Power
980	Unit Not Determined/No Trouble Found

#### 3271 Control Unit

010	Interface/Multiplex Controls
-----	------------------------------

#### 3272 Control Unit

020	Interface/Multiplex Controls
-----	------------------------------

#### 3275 Display Unit

200	Card Reader
100	Display (Control Logic)
110	Interface (Teleprocessing Controls)
040	Keyboard - Type B
300	Keyboard - Type A
584	Line Adapter

#### 3277 Display Unit

200	Card Readers
060	Display (Control Logic)
040	Keyboard - Type B
300	Keyboard - Type A

#### 3284/3286 Printer

001	Carriage and Paper Path
013	Maintenance Monitor
005	Print Head
030	Printer Control Logic
006	Ribbon and Ribbon Drive
007	Stepper Motor and Drive
009	Transport

**3271/3275/3284/3272/3277/3286**

The following major codes apply to all machines.

**Major Minor****000 Base**

- 01 Cables/Connectors
- 02 Covers
- 05 Forms Guides
- 03 Hinges
- 06 Interlocks
- 04 Latches-Mechanical
- 07 Shock Mounts
- 00 Other

**870 Customer Responsibility**

- 07 Carriage Controls
- 01 Electrical Failure (non-machine)
- 28 Forms
- 35 Interlocks
- 02 Operator Error
- 62 Ribbon
- 04 Temperature, Humidity
- 00 Other

**601 Power**

- 02 AC Power Distribution
- 01 Cables/Connectors
- 03 Capacitor
- 04 Fuse
- 09 High-Voltage Supply
- 05 Line Cord
- 06 Regulator Card
- 07 Secondary Power (Printed Circuit Board)
- 08 Transformer
- 00 Other

*Note:* Service Code 54 must be used when diagnosing, repairing, or adjusting maintenance tools (SIU, Probe, TDAT, etc.).

### 3275/3277 Display Unit

The following alphabetic list of major codes applies only to the machines indicated.

Major Minor

#### 200 Card Reader

- 10 Card (Circuit)
- 01 Reader Assembly
- 00 Other

### 3284/3286 Printer

Major Minor

#### 001 Carriage and Paper Path

- 02 Belts + Pulleys
- 04 Cables + Connectors
- 97 Circuit Board - Printed
- 14 Clutch Assembly
- 16 Coil - Magnet/Solenoid
- 26 Fan
- 27 Feed Roll Release Assembly
- 29 Fuse
- 33 Index Assembly
- 45 Motor - Carriage Drive
- 54 Platen + Controls
- 68 SLT Card - Driver
- 70 SLT Card Receptacle
- 76 Switch - Carriage Drive
- 77 Switch - End of Forms
- 81 Switch - Forms Moving
- 82 VFIC Sensor Assembly
- 83 VFIC Paper Weight
- 00 Other

*Note:* Service Code 54 must be used when diagnosing, repairing, or adjusting maintenance tools (SIU, Probe, TDAT, etc.).

## 3275/3277 Display Unit

Major Minor

060 3277 Control Logic

100 3275 Control Logic

The following minors apply to major codes 060 and 100.

- 13 Audible Alarm
- 02 Board
- 01 Cables/Connectors
- 03 Capacitor
- 14 Card - Analog
- 04 Card - Retainer
- 05 Card - 4 Wide
- 06 Card - 2 Wide
- 07 Card - 1 Wide
- 15 Cathode-Ray Tube
- 16 Keylock
- 08 Light-Emitting Diode
- 17 Selector Pen
- 09 Switches
- 10 Wiring (Board)
- 18 Yoke
- 00 Other

*Note:* Service Code 54 must be used when diagnosing, repairing, or adjusting maintenance tools (SIU, Probe, TDAT, etc.).

### 3271/3272/3275

Major Minor

- 010 3271 Interface-Multiplex Controls
- 020 3272 Interface-Multiplex Controls
- 110 3275 Interface (TP Controls)

The following minors apply to major codes 010, 020, and 110.

- 02 Board
- 01 Cables/Connectors
- 03 Capacitor
- 04 Card Retainer
- 05 Card - 4 Wide
- 06 Card - 2 Wide
- 07 Card - 1 Wide
- 11 Indicator Lamps - 3272 only
- 08 Light-Emitting Diode - 3271/3275
- 09 Switches
- 10 Wiring (Board)
- 00 Other

### 3275 Display Unit

584 Line Adapter

- 87 Receiver Circuits - Leased Line
- 89 Transmitter Circuits - Leased Line
- 00 Other - Switched Network Modem Card

*Note:* Service Code 54 must be used when diagnosing, repairing, or adjusting maintenance tools (SIU, Probe, TDAT, etc.).

### 3275/3277 Display Unit

The following major codes apply to the 3275/3277 Display Unit.

Major Minor

040 Keyboard - Type B

- 02 Audible Feedback Assembly
- 01 Cable/Connectors
- 03 Covers
- 04 Keyboard Assembly
- 36 Key Button/Keytop
- 08 Key Module
- 07 Printed Circuit (PC) Board
- 09 Spacebar Mechanism
- 00 Other

300 Keyboard - Type A

- 04 Assembly (Less Covers)
- 02 Audible Feedback Assembly
- 01 Cables/Connectors
- 36 Key Button
- 08 Key Module
- 09 Spacebar Module
- 00 Other

*Note:* Service Code 54 must be used when diagnosing, repairing, or adjusting maintenance tools (SIU, Probe, TDAT, etc.).

## 3284/3286 Printer

The following major codes apply to the 3284/3286 Printer.

**Major    Minor**

**013    Maintenance Monitor**

- 04    Cables + Connectors
- 44    Monitor Assembly
- 68    SLT Card - Driver
- 70    SLT Card Receptacle
- 00    Other

**005    Print Head**

- 04    Cables + Connectors
- 97    Circuit Board - Printed
- 49    Oil Wick
- 53    Print Head
- 55    Print Magnet (Armature + Wire)
- 57    Print Wire Guide
- 68    SLT Card - Driver
- 70    SLT Card Receptacle
- 00    Other

**030    Control Logic**

- 02    Board
- 01    Cables/Connectors
- 03    Capacitor
- 04    Card Retainer
- 12    Card SLT
- 05    Card - 4 Wide
- 06    Card - 2 Wide
- 07    Card - 1 Wide
- 09    Switches
- 10    Wiring (Board)
- 00    Other

**006 Ribbon and Ribbon Drive**

- 02 Belts + Pulleys
- 94 Bracket Assembly
- 11 Cassette Drive Roll
- 39 Guide - Ribbon
- 62 Ribbon
- 00 Other

**007 Stepper Motor and Drive**

- 04 Cables + Connectors
- 05 Capacitor
- 97 Circuit Board - Printed
- 19 Coupling
- 21 Diode
- 46 Motor - Stepper
- 61 Resistor
- 68 SLT Card - Driver
- 70 SLT Card Receptacle
- 87 Transducer - Forward Feedback
- 88 Transducer - Print Right
- 90 Transducer - Reverse Feedback
- 00 Other

**009 Transport**

- 09 Carrier
- 10 Carrier Support Shaft
- 37 Leadscrew
- 38 Leadscrew Bearing
- 40 Leadscrew Nuts
- 42 Magnet - Margin
- 43 Margin Stop Assembly
- 00 Other

### 3271/3272/3275

Major Minor

#### 960 Error Indicated/Trouble Not Isolated

- 01 Attention
- 02 Busy
- 03 Bus Out Check
- 04 Channel End
- 05 Command Reject
- 06 Control Check
- 07 Control Unit End
- 08 Data Check
- 09 Device Busy
- 10 Device End
- 11 Equipment Check
- 12 Intervention Required
- 13 Modifier (Status)
- 14 Op Check
- 15 Transmission Check
- 17 Unit Check
- 18 Unit Exception
- 16 Unit Specify
- 00 Other

#### 3277 Display Unit

- 01 Audible Alarm
- 02 Card Reader
- 03 Display (Control Logic)
- 07 Keyboard - Type B
- 04 Keyboard - Type A
- 05 Power
- 06 Selector Pen
- 00 Other

#### 3284/3286 Printer

- 01 Base
- 02 Carriage + Paper Path
- 07 Print Head
- 08 Ribbon + Ribbon Drive
- 09 Stepper Motor + Drive
- 11 Transport
- 00 Other

#### All Machines

#### 980 Unit Not Determined/No Trouble Found

- 01 Action suspended or transferred to someone else.
- 02 Trouble cannot be duplicated or is too intermittent to identify.
- 03 This unit not at fault: action follows on another unit.
- 00 Other

*Note:* Service Code 54 must be used when diagnosing, repairing, or adjusting maintenance tools (SIU, Probe, TDAT, etc.).

## Symptom Codes

Use in place of cause codes for majors 960 and 980.

### 3271/3272/3275

- 82 Control Unit Hang
- 83 Data Set and/or Line
- 84 Interrupt (Device)
- 85 More Than One Adapter
- 86 One Adapter
- 80 Power
- 00 Other

### 3275/3277 Display Unit

- 71 Audible Alarm
- 72 Card Reader
- 73 Characters
- 74 Cursor
- 75 Indicators
- 76 Intensity/Focus
- 77 Keyboard
- 78 No Display
- 79 Nonlinear Horizontal/Vertical Position or Size
- 80 Power
- 81 Selector Pen
- 00 Other

### 3284/3286 Printer

- 86 Erratic Motion
- 76 Extra Dots
- 78 Fails to Complete Print Line
- 71 Fails to Feed
- 77 Fails to Print Complete Character
- 79 Fails to Reverse
- 87 Fails to Start
- 88 Fails to Stop Left Margin
- 89 Fails to Stop Right Margin
- 72 Feeds Incorrectly
- 73 Forms Jam
- 94 Lifts Out of Guide
- 99 Operator Error
- 81 Platen Fails to Index
- 82 Print Quality Poor (Explain)
- 74 Skips Incorrectly
- 90 Speed Incorrect
- 84 Uneven
- 00 Other

## Cause Codes – All Machines

(Not to be used with majors 960 and 980)

- 02 Adjustment-Electrical
- 01 Adjustment-Mechanical
- 07 Bent
- 58 Binding/Sticking
- 09 Blown
- 13 Broken
- 16 Burned
- 15 Burred/Nicked
- 35 Changed Value
- 20 Damaged
- 21 Defective
- 24 Defective Solder/Weld/Crimp
- 23 Defective Wrap
- 22 Dirty
- 25 Dry
- 06 External Equipment Ground
- 05 External Radiation
- 52 Failure
- 28 Grounded
- 18 Jammed
- 31 Leaking
- 34 Loose/Reseated
- 38 Missing
- 40 Off Registered
- 42 Open
- 08 Power Line Disturbance
- 46 Shorted
- 54 Static
- 64 Tension
- 65 Timing/Sequence
- 66 Tripped/Unlatched
- 69 Weak
- 37 Wiring Error
- 70 Worn
- 51 Wrong EC Level
- 00 Other

## 3275 Model III Display Unit

### Instructions

This guide is to be used when reporting trouble on the 3275 Model 3. Do not use for 3275 Models 1 and 2; use Form S229-7018.

### Repair Action

Locate the failing function in the Alphabetic List.

Insert 0, 1, 2, or 3 for the X in the units position of the major code using the following guide:

- 0 — MAP not effective, failing box not determined by customer
- 1 — MAP not effective, failing box determined by customer
- 2 — MAP effective, failing box not determined by customer
- 3 — MAP effective, failing box determined by customer

Record the 3-digit major with applicable insert and 2-digit minor code in the unit field on the IR.

Record the appropriate 2-digit cause code in the cause field on the IR.

### Alphabetic List of Major Functional Codes

000	Base
870	Customer Responsibility
10X	Display (Control Logic)
04X	Keyboard Type B
60X	Power
960	Unit Determined, Trouble Not Isolated
980	Unit Not Determined, No Trouble Found
35X	Store Loop Integrated Modem

#### Major    Minor

##### 000    Base

- 01    Cables/Connectors
- 02    Covers
- 03    Hinges
- 04    Latches-Mechanical
- 00    Other

##### 04X    Keyboard-Type B

- 02    Audible Feedback Assembly
- 01    Cable/Connectors
- 03    Covers
- 04    Keyboard Assembly
- 36    Key Button/Keytop
- 08    Key Module
- 07    Printed Circuit (PC) Board
- 09    Spacebar Mechanism
- 00    Other

**10X Display (Control Logic)**

- 13 Audible Alarm
- 02 Board
- 01 Cables/Connectors
- 03 Capacitor
- 14 Card-Analog
- 04 Card-Retainer
- 05 Card-4 Wide
- 06 Card-2 Wide
- 07 Card-1 Wide
- 15 Cathode-Ray Tube
- 16 Keylock
- 08 Light-Emitting Diode
- 17 Selector Pen
- 09 Switches
- 10 Wiring (Board)
- 18 Yoke
- 00 Other

**35X Store Loop Integrated Modem**

- 01 B-H2 (Board-Card)
- 02 B-J2
- 03 B-K2
- 04 B-L2
- 05 B-M2
- 06 B-N2
- 07 B-G2

**60X Power**

- 02 AC Power Distribution
- 01 Cables/Connectors
- 03 Capacitor
- 04 Fuse
- 09 High-Voltage Supply
- 05 Line Cord
- 06 Regulator Card
- 07 Secondary Power (Printed Circuit Board)
- 08 Transformer
- 00 Other

**870 Customer Responsibility**

- 01 Electrical Failure (Non-Machine)
- 02 Operator Error
- 04 Temperature, Humidity
- 00 Other

**960 Error Indicated/Trouble Not Isolated**

- 01 Audible Alarm
- 03 Display (Control Logic)
- 07 Keyboard-Type B
- 05 Power

**980 Unit Not Determined/No Trouble Found**

- 01 Action suspended or transferred to someone else.
- 02 Trouble cannot be duplicated or is too intermittent to identify.
- 03 This unit not at fault: action follows on another unit.
- 00 Other

### Symptom Codes

Use in place of cause codes with major codes 960 and 980.

- 71 Audible Alarm
- 73 Characters
- 82 Control Unit Hangs
- 74 Cursor
- 75 Indicators
- 76 Intensity/Focus
- 77 Keyboard
- 78 No Display
- 79 Nonlinear Horizontal/Vertical Position or Size
- 80 Power
- 87 Store Loop Integrated Modem
- 00 Other

### Cause Codes

(Not to be used with majors 960 and 980)

- 02 Adjustment - Electrical
- 01 Adjustment - Mechanical
- 07 Bent
- 58 Binding/Sticking
- 09 Blown
- 13 Broken
- 16 Burned
- 15 Burred/Nicked
- 35 Changed Value
- 20 Damaged
- 21 Defective
- 24 Defective Solder/Weld/Crimp
- 23 Defective Wrap
- 22 Dirty
- 25 Dry
- 06 External Equipment Ground
- 05 External Radiation
- 52 Failure
- 28 Grounded
- 18 Jammed
- 31 Leaking
- 34 Loose/Reseated
- 38 Missing
- 40 Off Registered
- 42 Open
- 08 Power Line Disturbance
- 46 Shorted
- 54 Static
- 64 Tension
- 65 Timing/Sequence
- 66 Tripped/Unlatched
- 69 Weak
- 37 Wiring Error
- 70 Worn
- 51 Wrong EC level
- 00 Other

## 3288 Model II

### Alphabetic List of Major Function Codes

000	Base
520	Carriage and Paper Path
100	Control Logic
870	Customer Responsibility
521	Electronics
960	Error Indicated - Trouble Not Isolated
600	Power Supply
522	Print Mechanism
523	Print Unit (Front Casting Asm)
980	Unit Not Determined/No Trouble Found

### Minor within Major Listing

#### 000 Base

01	Cables + Connectors
02	Covers
03	Indicators
04	Relay-Bypass
05	Switches
00	Other

#### 100 Control Logic

01	Cables/Connectors
02	Board
03	Capacitor
04	Card Retainer
05	Card - 4 Wide
07	Card - 1 Wide
10	Wiring (Board)
00	Other

#### 520 Carriage and Paper Path

12	Belt
01	Clamp - Upper Paper
02	Clamp - Lower Paper
03	Forms Drag Assembly
04	LED - Forms Jam
24	Motor Stepper
31	Switch - End of Forms
05	Tractors
06	Vernier/Knobs
00	Other

#### 521 Electronics

13	Blower
15	Cables/Connectors
16	Capacitors/Resistors
01	Mounting Hardware
26	Relay - 24V
17	SLT Card
31	Switch - Cover Interlock
32	Thermal
20	Zener Diode
00	Other

- 522 Print Mechanism**
- 01 Block Assembly
  - 02 Coil
  - 03 Hammer
  - 04 Pivot Pin
  - 05 Platen
  - 06 Print Belt
  - 07 Print Belt Guide Rolls
  - 08 Print Belt Pulleys
  - 09 Print Position Indicator (LED)
  - 00 Other
- 523 Print Unit (Front Casting Assembly)**
- 12 Belt - Ribbon Drive
  - 01 Clutch Assembly
  - 21 Drive Rolls - Ribbon
  - 02 Forms Thickness Control
  - 03 Guides - Ribbon
  - 24 Motor - Stepper
  - 04 Shield - Ribbon
  - 31 Switch - Front Casting Interlock
  - 33 Transducer
  - 00 Other
- 600 Power Supply**
- 01 Assembly
  - 02 Cables + Connectors
  - 03 Capacitor
  - 04 Ferro - -24V
  - 05 Line Cord
  - 06 Regulator Card
  - 07 PC Board
  - 08 Transformer
  - 09 Fuse
  - 00 Other
- 870 Customer Responsibility**
- 03 Ribbon Unit
  - 04 Print Belt
  - 56 Forms
  - 54 Carriage Controls
  - 60 Interlock
  - 00 Other
- 960\* Error Indicated - Trouble Not Isolated**
- 01 Carriage and Paper Path
  - 02 Electronics
  - 03 Hammer Unit
  - 04 Print Unit
  - 05 Ribbon Unit
  - 00 Other
- 980\* Unit Not Determined/No Trouble Found**
- 01 Action suspended or transferred to someone else.
  - 02 Trouble cannot be duplicated or is too intermittent to identify.
  - 03 This machine not at fault: action follows on another machine.
  - 00 Other

\*Use symptom codes in cause field.

### Symptom Codes

Use in place of cause codes with major codes 960 and 980.

- 36 Fails to Print Complete Char.
- 39 Fails to Print Complete Line
- 43 Forms Fail to Feed
- 44 Forms Jam
- 45 Forms Run Away
- 72 Prints Extra Characters
- 75 Ribbon Fails to Feed
- 76 Ribbon Jams
- 79 Spaces Incorrectly
- 71 Power Problem, Internal
- 00 Other

### Cause Codes

(Not to be used with major codes 960 and 980)

- 01 Adjustment
- 07 Bent
- 58 Binding/Sticking
- 09 Blown
- 13 Broken
- 16 Burned
- 20 Damaged
- 24 Defective Weld/Solder/Crimp
- 23 Defective Wrap
- 22 Dirty-Corroded
- 25 Dry
- 18 Jams
- 31 Leaking
- 34 Loose/Reseated
- 38 Missing
- 42 Open
- 46 Shorted/Grounded
- 54 Static
- 64 Tension
- 69 Weak
- 37 Wiring Error
- 70 Worn
- 51 Wrong EC Level
- 00 Other

## Section 2. 3271 Control Unit

### Contents

<b>3271 Symptom Fix List</b> . . . . .	2-3
<b>3271 Model 1 and 2 Card Substitution List</b> . . . . .	2-12
Basic Unit . . . . .	2-12
Feature or RPQ Units . . . . .	2-14
3271 Common Board Part Numbers . . . . .	2-14
<b>3271 Model 1 and 2 EC Cross-Reference</b> . . . . .	2-15
<b>3271 Service Aids</b> . . . . .	2-20
Cables and Connectors . . . . .	2-20
Cards and Boards . . . . .	2-20
Modems and Lines . . . . .	2-20
Programming . . . . .	2-22
Power Supplies . . . . .	2-23
Tools and Test Equipment . . . . .	2-23

### Figures

Figure 2-1. 3271 CU Functional Block Diagram (4 parts) . . . . .	2-7
Figure 2-2. 3271 A-Gate Card Layout by Function . . . . .	2-11
Figure 2-3. 3271 Model 1 and 2 EC Cross-Reference Chart (5 parts) . . . . .	2-15



## Section 2. 3271 Control Unit

### Contents

<b>3271 Symptom Fix List</b> . . . . .	2-3
<b>3271 Model 1 and 2 Card Substitution List</b> . . . . .	2-12
Basic Unit . . . . .	2-12
Feature or RPQ Units . . . . .	2-14
3271 Common Board Part Numbers . . . . .	2-14
<b>3271 Model 1 and 2 EC Cross-Reference</b> . . . . .	2-15
<b>3271 Service Aids</b> . . . . .	2-20
Cables and Connectors . . . . .	2-20
Cards and Boards . . . . .	2-20
Modems and Lines . . . . .	2-20
Programming . . . . .	2-22
Power Supplies . . . . .	2-23
Tools and Test Equipment . . . . .	2-23

### Figures

Figure 2-1. 3271 CU Functional Block Diagram (4 parts) . . . . .	2-7
Figure 2-2. 3271 A-Gate Card Layout by Function . . . . .	2-11
Figure 2-3. 3271 Model 1 and 2 EC Cross-Reference Chart (5 parts) . . . . .	2-15



## Section 2. 3271 Control Unit

Figures 2-1 and 2-2 give the locations for the 3271 Control Unit.

### 3271 SYMPTOM FIX LIST

The following Symptom Fix List should be used to supplement the existing troubleshooting procedures in the MLTG.

#### CAUTION

Turn Power Off. Do not attempt to swap cards or cables with Power On.

2

Symptom	Fix
ACK— incorrect or out of sequence	Install EC 740861.
AID— character wrong	Replace A1M2 card.
Attribute not recognized	Replace A1M2 card.
Attribute displayed as character	Replace A1H2 card.
“Bad Data” displayed on 3277	Replace A1N2 or A1C2 card.
“Bad Data” on Buffer Transfer	Replace A1M2 card.
“Bad Data” transmitted	Replace A1D2 card.
BCC Character failure	Replace A2D2 card
Byte count hang in Poll-Poll	Replace A1M2 card.
Byte counter won't step	Reseat or replace cable from A1Z3 to A2H2.
Cannot communicate with host	Replace A1G2 card.
Carrier (unsolicited) comes up	Reseat or replace cable in position A2J2.
Check Routine 04 failure	Replace A1L2 card.
Continuous carrier or 4C04 status	Replace A1G2 card.
Control Unit hangs with Device Busy	Replace A1J2 card.
Copy command failure	Install ECA 027 (EC 740022) or replace A1C2 card.
Cursor Checks	Install EC 740398
Data Checks	Replace -12V regulator card or F2 (-12V fuse), or replace A1M2 card.
Data Checks (all attached devices)	Replace A1D2 card.
Data Check and Unit Specify	Replace A1D2 and/or A1F2 card in the 3277.
Data Check on Initial Selection	Replace A1K2 card.

Symptom	Fix
Data Check on status message of Device End	Replace A1G2 card.
Data errors with or without Data Checks	Tighten capacitor screws on power supply.
Data mixed up on screen	Replace A1P2 and/or A1D2 card.
Data transfer to or from any device fails	Replace A1F2 card.
Device End presented erroneously	Replace A1N2 card.
Display size of Model 2 reduced to Model 1 size	Replace A1J2 card.
Drops bits on Read command	Reseat or replace cable from A1Z2 to A2J2.
Drops characters of Receive Data (no errors)	Replace A1F2 card.
Drops data on all displays	Replace A1E2 card.
Drops text character on Read Modified	Replace A1C2 card.
Drops bytes of data (randomly)	Install jumper from A1F2D06 pin to ground. (EC 742201)
Erase/Write Sequence 5 failure	Replace A1M2 card.
Erase/Write Sequence 8 failure	Replace A1D2 card.
EOT instead of ACK	Replace A1E2 card.
EOT reply missing after RVI from Host	Replace A2F2 card.
EOT response to Write command (any device)	Replace A1C2 card.
ETB sent at wrong time	Check for missing jumper on A2E2 card.
ETX invalid	Replace A2E2 card.
Extra spaces on 3277	Replace A1E2 card.
General Poll failure	Check jumpers on A2F2 card.
Hot Bit in SERDES	Replace A2G2 card.
Incorrect (bad) data transmitted	Replace A2E2, A1N2, or A1F2 card.
Initial Selection failure	Replace A1P2 or A1B2 or Device Adapter card.
Intervention Required	Replace fuse F3 or replace A1N2 or A1J2 or A1P2 card.
Intervention Required (all devices)	Replace A1B2 or A1P2 card.
Intervention Required (status on first device address)	Replace Device Adapter card.

Symptom	Fix
IO Register Loaded failure	Replace A1E2 card.
Locks up	Replace A1G2 card.
Lost information	Replace A1H2 or A1D2 card.
Loses bytes of data (randomly)	Install jumper from A1F2D06 to ground. (EC 742201)
Poll Poll fails	Replace buffer card.
Poll Poll inoperative	Replace A1C2 card.
Poll Poll not running	Reseat or replace cable between position A2H1 and A1Z3 or replace A1N2 or A1M2 card.
Poll failure (all units)	Check jumpers on A2F2 card.
Poll failure (no response)	Replace A2E2 card.
Poll response correct, unable to transmit	Replace A1K2 card.
Poll response slow	Check for short in interface cable.
Power on reset failure, timeout	Replace A1B2 card.
Random data on displays	Replace A1E2 card.
Read command failure	Replace A2G2 card.
Read Modified failure from SIU	Replace A1D2 card.
Receives correctly, will not transmit	Replace A2J4 card.
Repeat to address order failures	Replace A1D2 card.
Request to Send up solid	Replace A2G2 or A2B2 card or replace +5V fuse.
SERDES cannot be reset	Replace A1K2 card.
SERDES resets on first Device Address	Reseat or replace cable in position A2H3.
SERDES resets on second Device Address	Replace A1F2 card.
Short on board	Replace defective board voltage jumper.
Specific Poll failure	Check jumpers on A2F2 card.
Start Pad character incorrect	Replace A2G2 card.
STATUS indicator on	Replace A1E2 or A1P2 or A1J2 or A2D2 card.
Status of Data Check	Replace A1F2 card.
Status of OP check on Write from SIU	Replace A2J4 card (high bps only).

Symptom	Fix
Status on Initial Selection	Replace A1L2 card.
Status or Data Checks after POR	Replace A1C2 card.
Status and Sense bytes missing at CPU	Replace A1F2 card.
Status on Erase/Write command	Replace A1R4 or A1Q4 card.
STX missing on Read Modified	Reseat or replace cable from A1Z3 to A2H2.
SYNC SEARCH indicator will not go off	Replace A1D2 card.
Transmit data contains multiple 3F or 7F characters instead of ETX	Replace A1E2 card.
Timeouts	Replace A1L2 or A1H2 or A1F2 or A2B2 or A2G2 or A2E2 or reseat flat cable A2A2.
Timeout and Op Check	Replace A2J4 card (high bps only).
Timeouts and Status message	Check 5V bus.
Timeout (lost data)	Replace A1L2 and A1N2 cards.
Timeout (no response to initial selection)	Replace A1C2 card.
Timeout (Power On Reset failure)	Replace A1B2 card.
Timeouts (Sequence 8 Read problem)	Replace A1E2 card.
Timeouts (intermittent)	Check for excessive power supply ripple.
Transmit failure, receives correctly	Replace A2J4 card (high bps only).
Turnaround failure after polling or address sequence	Replace A1N2 card.
Unit Exceptions	Replace buffer card or A2E2 card.
Unit Specify or WACK	Replace A1K2 card.
Write command failure	Replace A1M2 or A1F2 card, reseat or replace cables in positions A2A2 and A1Y1.
Write command Sequence 8 failure	Replace A1M2 card.
Write command failure (no data transfer)	Replace A2B2 card.
3277 displays only quotation mark (") on Write command	Replace A1E2 card.
3284 Uneven margin-extra spaces	Replace A1D2 card.

A. Data Flow of Remote Interface Portion

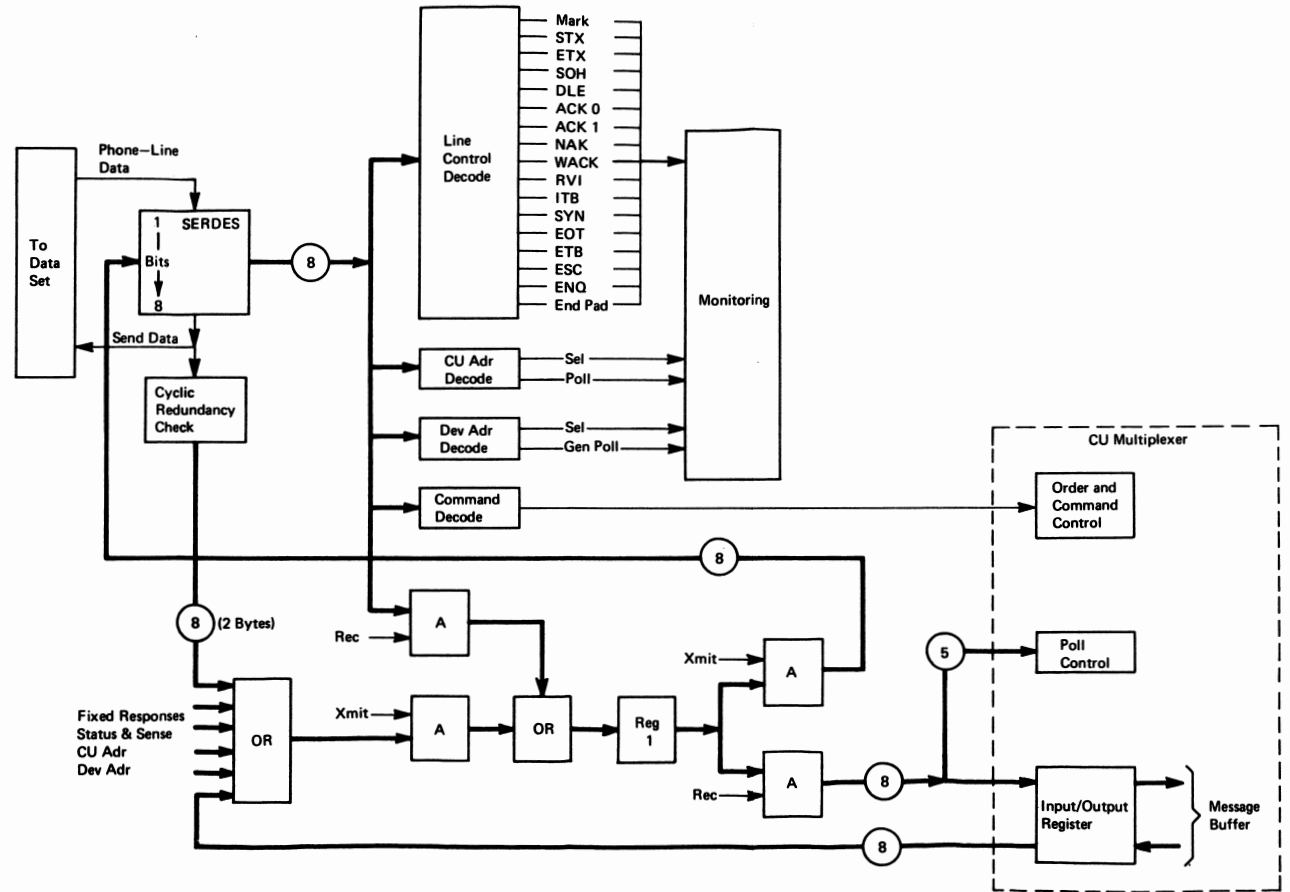

Figure 2-1 (Part 1 of 4). 3271 CU Functional Block Diagram

B. Data Flow of Multiplexer Portion

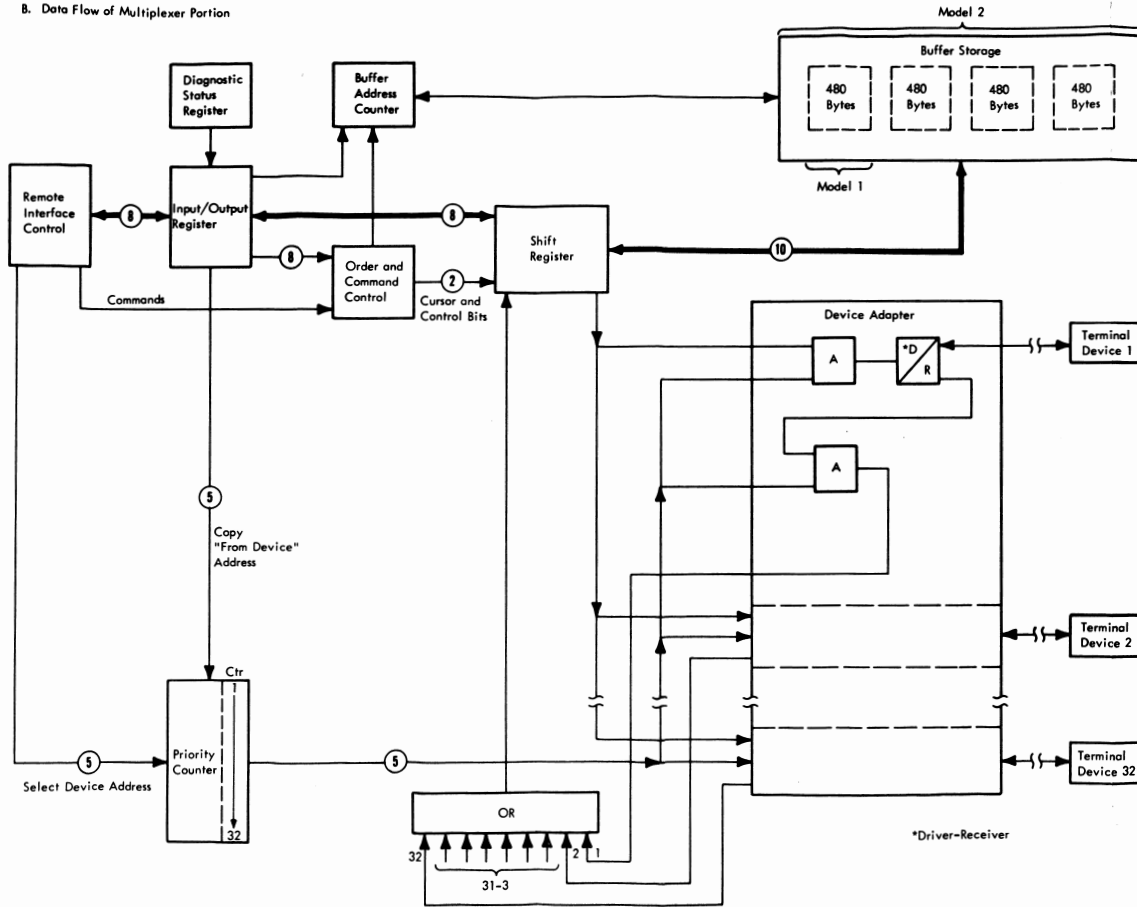

Figure 2-1 (Part 2 of 4). 3271 CU Functional Block Diagram

C. CU Buffer Storage Address Control

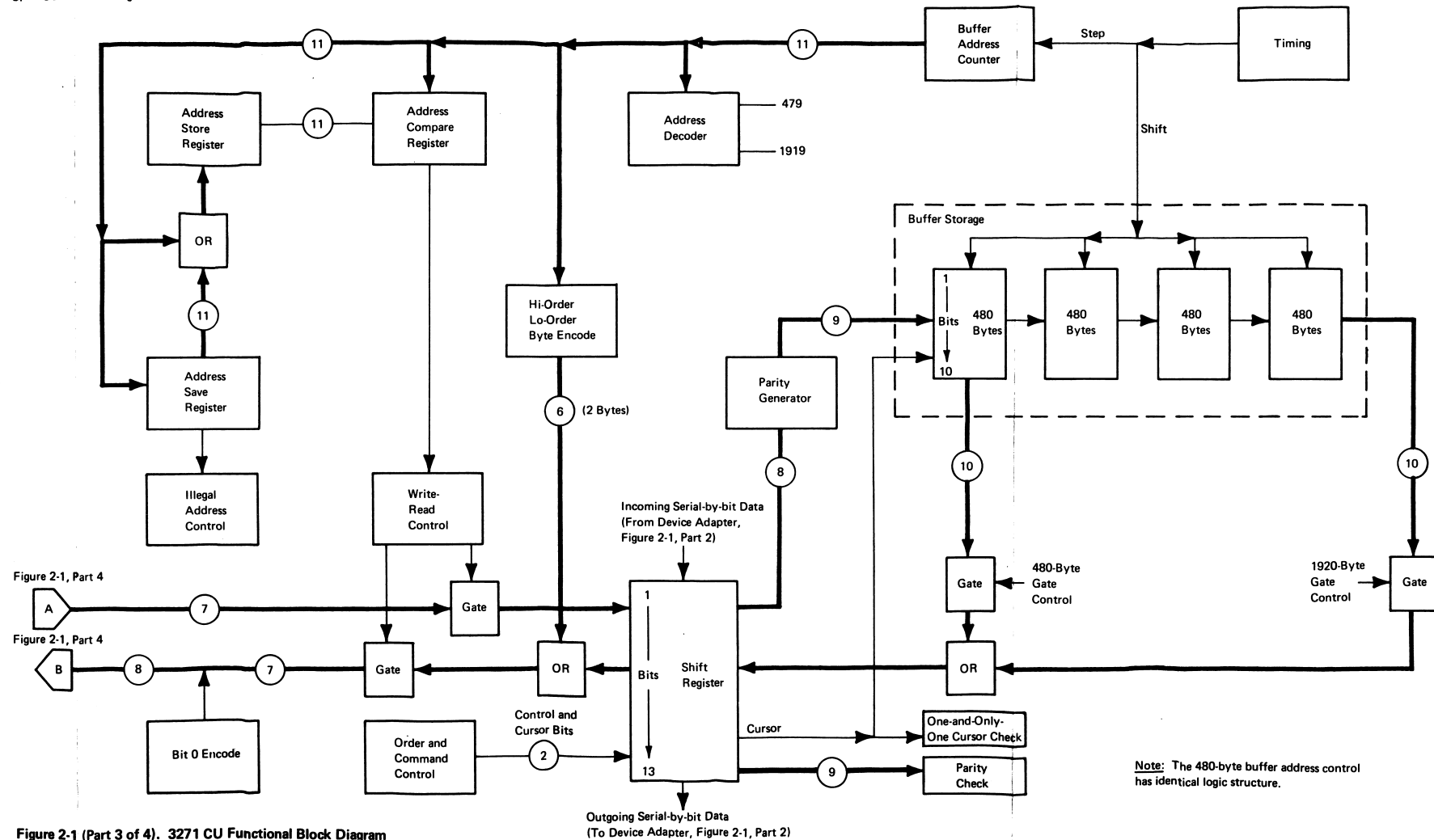

Figure 2-1 (Part 3 of 4). 3271 CU Functional Block Diagram

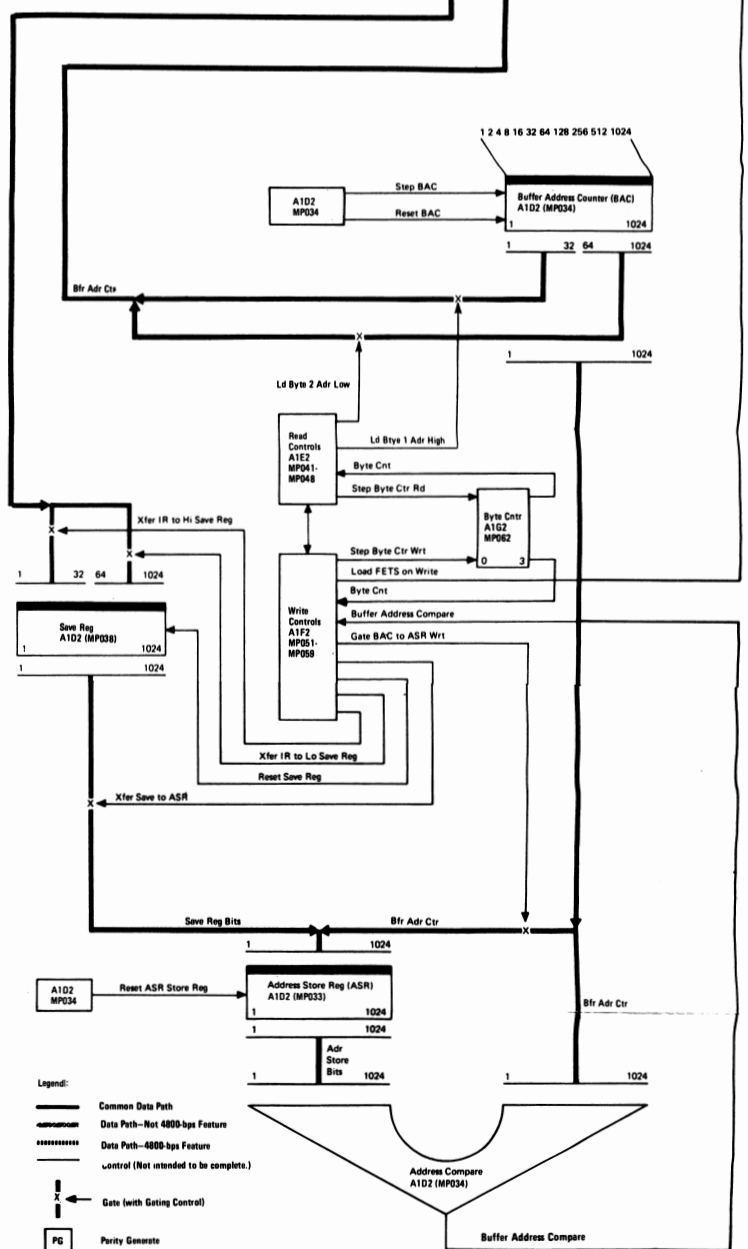
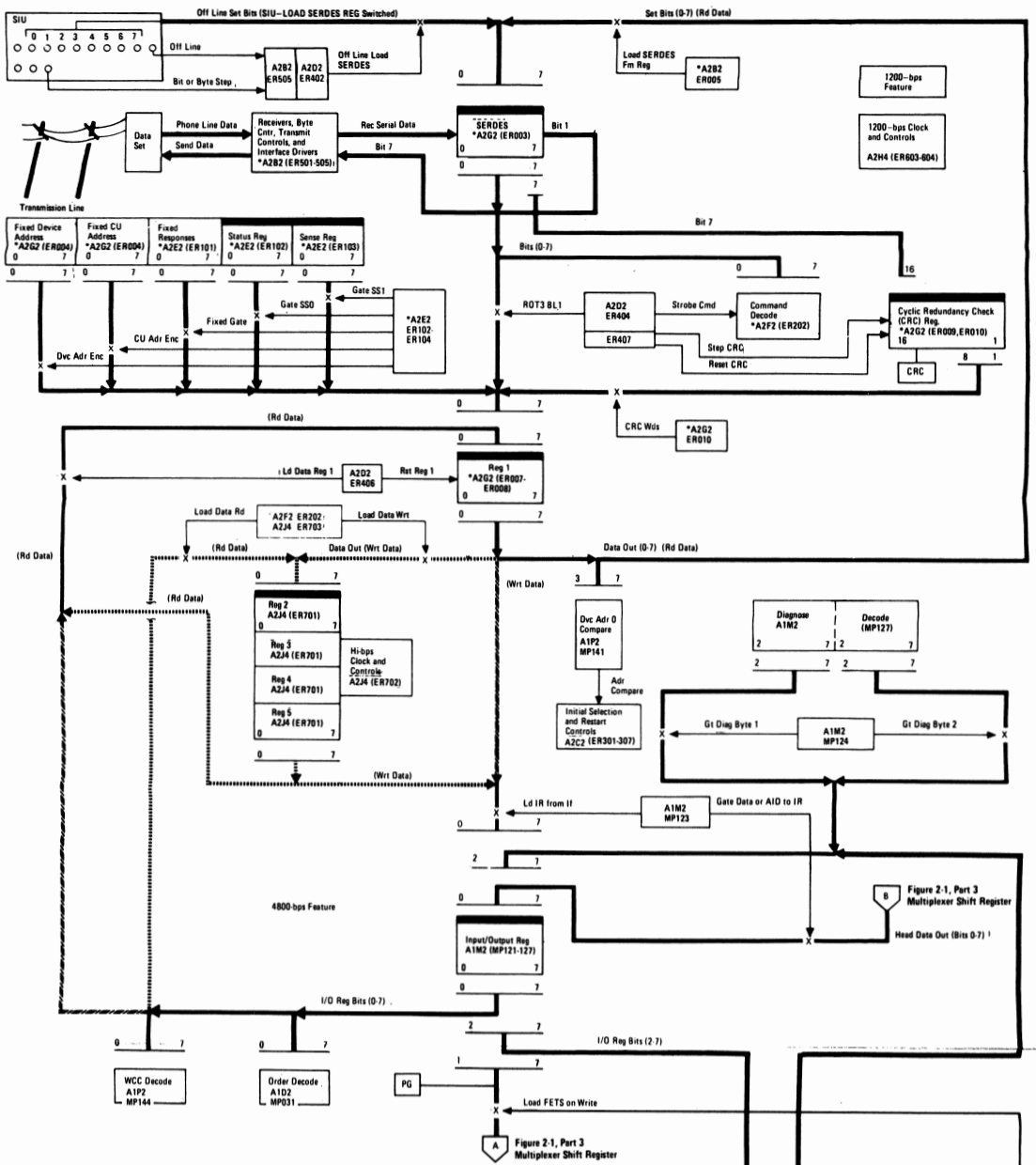
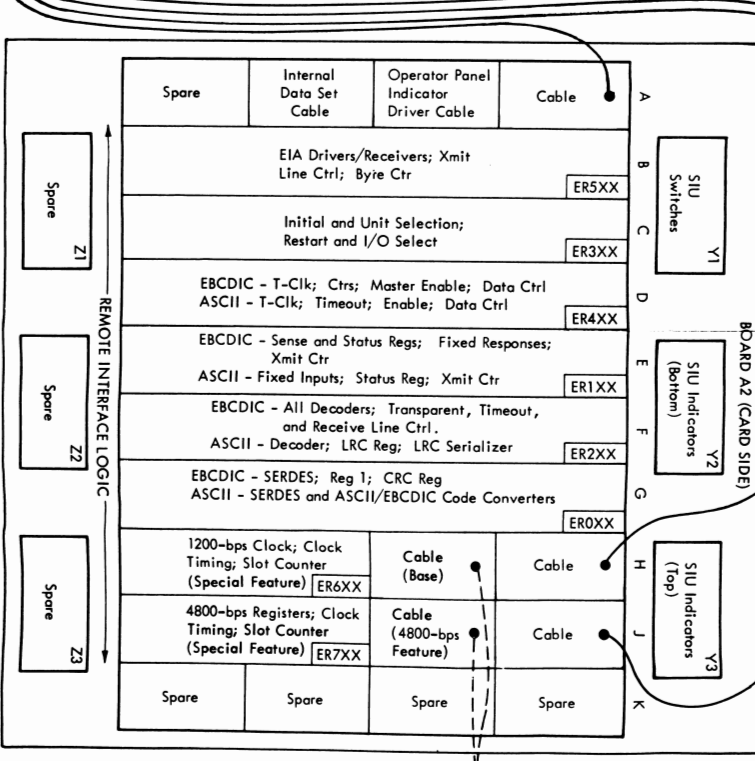
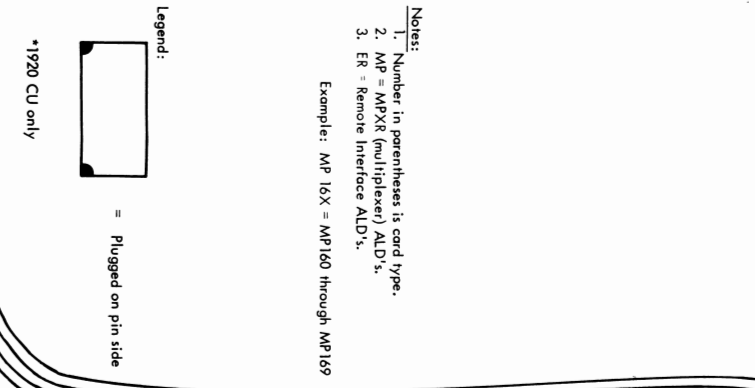
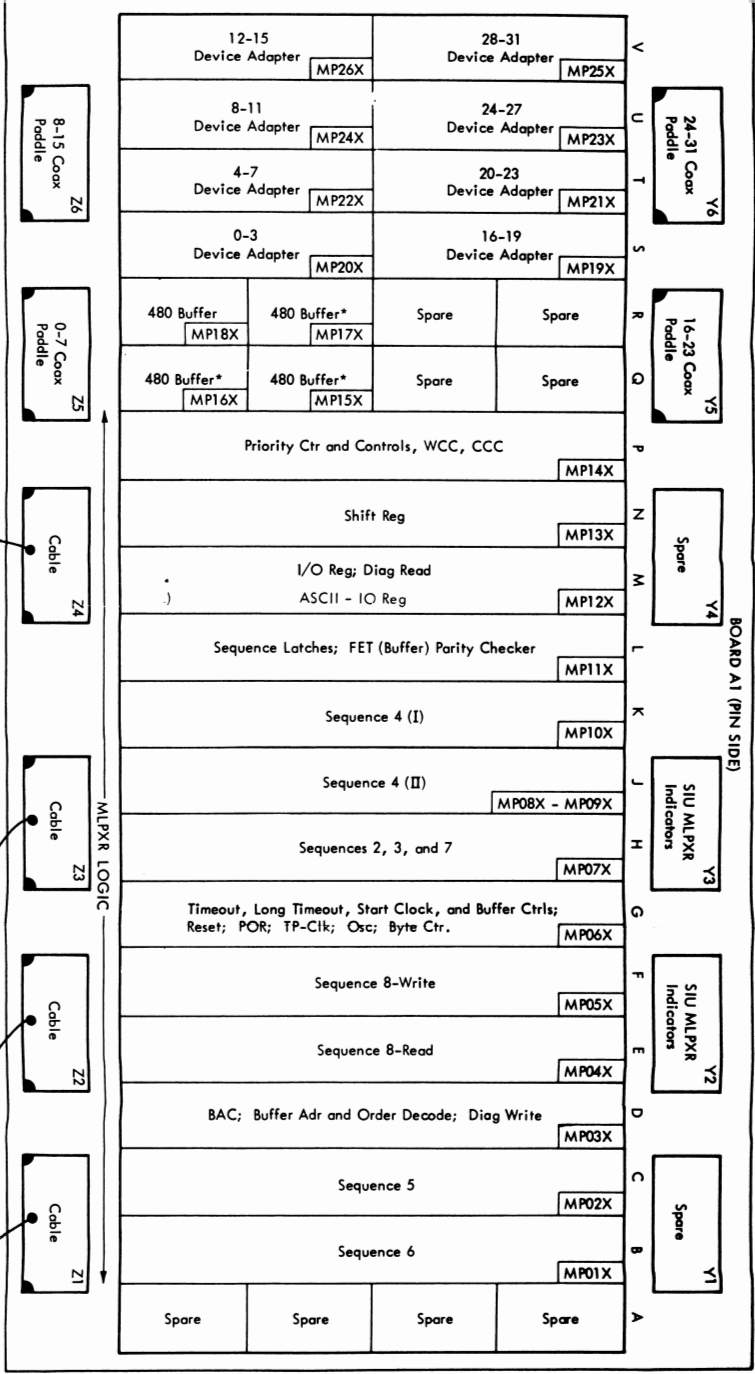

Figure 2-1 (Part 4 of 4) 3271 CU Functional Block Diagram

2-2. 3271 A-Gate Card Layout by Function



**3271 MODEL 1 AND 2 CARD SUBSTITUTION LIST**

The following is a card substitution list approved only for use in the U  
3271 Control Units.

**Key**

- FO = Factory Only
- NA = Not Available
- CC = Needs Companion Card
- BW = Needs Board Wiring
- MR = Minimum Rework - Functionally equivalent to the PN I  
below it.

The Underlined PN is the latest level card.

Cards may be substituted up or down as long as board wiring (BW)

**Basic Unit**

Loc	PN	Key	ECA/EC	Function/Comment
A1B2----	8522126	MR	003/717489	Sequence 6
	<u>8522840</u>		FO/718543	
	8523624		FO/718975	
	8523659		026/739559	
	<u>8564141</u>		/747005	
A1C2----	8522107	MR	003/717489	Sequence 5
	8521829			
	8522841		FO/718546	
	8522861		007/718942	
	<u>8524587</u>		027/740022	
A1D2----	<u>8521716</u>		003/717489	BAC/Order Decode
A1E2----	8521725	BW,CC	003/717489	Sequence 8 Read
	8522830		005/717956	
	8524319		019/739278	
	<u>8563022</u>		/745462	
A1F2----	8521990	MR	003/717489	Sequence 8 Write
	8521523		FO/718543	
	8524575	CC*	FO/739265	
				*CC for Katakana (WTC) only
		<u>8527304</u>		FO/741773
	<u>8564142</u>		/747006	
A1G2----	8521969	CC	003/717489	Clock
	<u>8523635</u>		FO/738655	
A1H2----	8522129	MR	003/717489	Sequence 2, 3, and
	8522834		006/718544	
	8522839			
	<u>8523634</u>	BW,CC	FO/738655	
A1J2----	8522119	CC	003/717489	Sequence 4
	8522152		004/717949	
	<u>8522858</u>		FO/718940	
A1K2----	8522009	CC	003/717489	Sequence 4
	<u>8522139</u>		004/717949	

**Basic Unit (cont)**

Loc	PN	Key	ECA/EC	Function/Comments
A1L2----	8521414 8523655 <u>8526057</u>		003/717489 FO/739553 029/740398	Buffer Parity
A1M2----	8521852 <u>8526062</u>		003/717489 FO/740393	I/O Reg
A1N2----	8522138 <u>8522831</u>	CC	003/717489 005/717956	Shift Reg
A1P2----	<u>8522124</u>		003/717489	Priority Ctr
A1Q4/5				
A1R4/5	<u>8521985</u>		003/717489	Buffer
A1S4----	8521508 8522141 <u>8522147</u>	MR CC	003/717489 004/717949	Device Adapter
A2B2----	8521516 8523640 8523658 8526047 8523662* <u>8527981</u>	MR BW	003/717489 FO/738653 FO/739558 032/740036 032/740036 NA/742873	EIA Driver/Receivers
A2C2----	8521978 8528269 <u>8528270</u>	MR BW	003/717489 046/744154	Init. + Unit Selection Message Switching
A2D2----	<u>8521967</u>		003/717489	T - Clock
A2E2----	8521712 8522868 8523645 8526059 <u>8527916</u>	BW	003/717489 010/718947 017/739064 033/740861 NA/742861	Status and Sense Regs
A2F2----	8521865 8526054 8527295 8528256 <u>8565001</u>	MR	003/717489 FO/740024 034/741253 044/743330 747500	All Decoders
A2G2----	<u>8521864</u>		003/717489	Serdes

\*PN 8523662 can be used on U.S. machines in emergency situations without adding the board wiring. ECA 032 should then be ordered and installed.

## Feature or RPQ Units

Loc	PN	Key	ECA/EC	No./Description
A1E2----	<u>8527903</u>		NA	APL
A1J2----	<u>8526696</u>		NA	APL
A1M2----	<u>8522845</u>		718552	ASCII I/O Register
A1N2----	8524283		NA	AB4820/5000 Ft (1 524 m) RPQ
	<u>8524321</u>		739277	AB4820/5000 Ft (1 524 m) RPQ
A1N2----	8527983		NA	APL
	8527996		743326	APL
	8528266	MR	REA06-82544	APL
			(743332)	
	<u>8528267</u>		743332	APL
Adapter-	8523252		NA	AB4820/5000 Ft (1 524 m) RPQ
	<u>8524318</u>		739277	AB4820/5000 Ft (1 524 m) RPQ
Adapter-	<u>8527294</u>		NA	8K0566 Lightning Protection RPQ
A2B2----	<u>8528261</u>		743337	FB0613/Mil Spec
A2D2----	<u>8521968</u>		003/717489	ASCII
A2E2----	8521448		003/717489	ASCII
	8522869		010/718947	ASCII
	8523646		017/739064	ASCII
	<u>8527977</u>	BW	NA/742861	ASCII
A2F2----	8522005		003/717489	ASCII
	<u>8528257</u>		NA/743330	
A2G2----	8521447		003/717489	ASCII
	<u>8522849</u>		008/718552	
A2H4----	<u>8521824</u>		003/717489	Low bps
A2J4----	8522130		003/717489	High bps
	8522131			
	8528260		048/743336	7200 bps
	8527986		NA/745476	9600 bps 8K0498
	<u>8563031</u>			
A2K2----	8522855		718559	FB0613/Mil Spec
	<u>8524284</u>		739267	

*Note:* For 3271 Models 11 and 12 SDLC card part numbers, refer to Section 8 of this manual.

## 3271 Common Board Part Numbers

Loc	PN	Description
A1	2625220	Base
	1653796	50001 RPQ, Ver 20
	1840930	50001 RPQ, Ver 40
	1739986	APL

### 3271 Model 1 and 2 EC Cross-Reference

This chart (Figure 2-3) is to be used to determine the need for any of the optional EC changes and to verify the EC level of any machine. To aid in determination the serial number that implemented each change is listed. This list will be updated periodically. It is recommended that a copy of this service aid be kept in 3270 card caddies.

ECA	EC	REA	Pre-Req ECA	Concur or Comp	Opt/Mand	Feature Affected	Break In Serial #	Cards Affected		Board Wiring Involved	Card Loc	Card Type	Description
								Old P/N	New P/N				
001	716954			None	Mand		10057						Factory installed on all machines.
002	717482			None	Mand		10057						Factory installed on all machines.
003	717489		3277 ECA 002 3284 ECA 003	None	Mand		10152	8521834 8522007	8522138 8522141	Yes	A1N2 A1S4	2219 L510	Correct device adapter card for addressing more than four devices.
004	717949		ECA 004	None	Mand		10152	8522119 8522009	8522152 8522139	Yes	A1J2 A1K2	9129 2221	Correct spurious Device-Ends, separate generation of device-ends and attention, add metering-in when printing.
005	717956		ECA 004	None	Opt		10666	8521725 8522138	8522830 8522831	Yes	A1E2 A1N2	2218 2219	Fixes "Read Modified" with tagged attribute in last buffer location with untagged attribute preceding.
006	718544		ECA 004	None	Mand		10666	8522129	8522839 or 8522834	None	A1H2	2220	Loss of data in position 0 with tagged attribute in last buffer position.
007	718942		ECA 004	None	Opt		10666	8521829	8522861	None	A1C2	9128	Composite EC to prevent hang on Read Modified command if there is an untagged attribute in last buffer position and no other attributes in buffer.
008	718552		ECA 004	None	Mand	ASCII	10728	8521852 8521447	8522845 8522849	None	A1M2 A2G2	9033 9110	ASCII conversion problem (ASCII machines only)
009	717949C		ECA 004	None	Mand		10847			None			Update Socket List
010	718947		ECA 004	None	Opt	EBCDIC ASCII	11109	8521443 or 8521712 8521448	8522868  8522869	None	A2E2 A2E2	9041 9111	"Line Hit" on message to 3271 results in retransmission which may result in wrong Ack. Expected Ack 0, received Ack 1.
011	718956		ECA 004	None	Opt W T C only		11109						World Trade only
012	718335			None	Mand		11443			None			Update IR Code Guide
013	718556		None	None	Mand					None			Provide 3277 "Max Pack" logics to early ship control units.
014	738897		None	None	Mand		11659			None			Prevent burning of 5 volt return line connectors
015	738790		None	None	Mand		12571			None			Connector spring clip installation

Figure 2-3 (Part 1 of 5). 3271 Model 1 and 2 EC Cross-Reference Chart

ECA	EC	REA	Pre-Req ECA	Concur or Comp	Opt/Mand	Feature Affected	Break In Serial #	Cards Affected		Board Wiring Involved	Card Loc	Card Type	Description
								Old P/N	New P/N				
016	738653												This ECA was cancelled.
017	739064		ECA 004	None	Opt	EBCDIC ASCII	12530	8521712 or 8522868 8521448 or 8522869	8523645  8523646	None	A2E2 A2E2	9041 9111	Wrong Ack on odd number of temporary text delays.
018	739540		ECA 004	None	Mand		12672			Yes			Resolves reread problem that occurs when doing a reread of a block of data.
019	739278		ECA 005	None	Opt		13462	8522830	8524319	None	A1E2	2218	Prevents read at wrong location and loss of SBA (light pen read) and address of modified attribute.
020	739265				Opt WTC only		14388	8521523	8524575	Yes	A1F2	9039	WTC only - U.S. mach picked up a portion of this EC which is the use of new A1F2 card & wiring. No U.S. FBMs available.
021	738794		None	None	Mand		N/A			None			Power Supply Logic update.
022	718969		None	Comp 3277 ECA 023	Mand		N/A			None			Logic update for 3277.
023	739065		None	Comp 3277 ECA 028	Mand		13165			None			Logic update for 3277.
024	739072		None	Comp 3277 ECA 029	Mand		N/A			None			Logic update for 3277.
025	739071		None	Comp 3277 ECA 032	Mand		13110			None			Logic update for 3277.
026	739559		ECA 004	None	Opt		14220	8523624	8523659	None	A1B2	2216	Prevents the loss of aid character when retransmitting a short read.
027	740022		ECA 004	None	Opt		13969	8522861	8524587	None	A1C2	9128	To correct data that was lost when retransmitting the last block of data in response to an NAK.
028	739268		None	Comp 3277 ECA 038	Opt		13530			None			Logic update for 3277.

Figure 2-3 (Part 2 of 5). 3271 Model 1 and 2 EC Cross-Reference Chart

ECA	EC	REA	Pre-Req ECA	Concur or Comp	Opt/ Mand	Feature Affected	Break In Serial #	Cards Affected		Board Wiring Involved	Card Loc	Card Type	Description
								Old P/N	New P/N				
016	738653												This ECA was cancelled.
017	739064		ECA 004	None	Opt	EBCDIC ASCII	12530	8521712 or 8522868 8521448 or 8522869	8523645  8523646	None	A2E2  A2E2	9041  9111	Wrong Ack on odd number of temporary text delays.
018	739540		ECA 004	None	Mand		12672			Yes			Resolves reread problem that occurs when doing a reread of a block of data.
019	739278		ECA 005	None	Opt		13462	8522830	8524319	None	A1E2	2218	Prevents read at wrong location and loss of SBA (light pen read) and address of modified attribute.
020	739265				Opt WTC only		14388	8521523	8524575	Yes	A1F2	9039	WTC only - U.S. mach picked up a portion of this EC which is the use of new A1F2 card & wiring. No U.S. FBMs available.
021	738794		None	None	Mand		N/A			None			Power Supply Logic update.
022	718969		None	Comp 3277 ECA 023	Mand		N/A			None			Logic update for 3277.
023	739065		None	Comp 3277 ECA 028	Mand		13165			None			Logic update for 3277.
024	739072		None	Comp 3277 ECA 029	Mand		N/A			None			Logic update for 3277.
025	739071		None	Comp 3277 ECA 032	Mand		13110			None			Logic update for 3277.
026	739559		ECA 004	None	Opt		14220	8523624	8523659	None	A1B2	2216	Prevents the loss of aid character when retransmitting a short read.
027	740022		ECA 004	None	Opt		13969	8522861	8524587	None	A1C2	9128	To correct data that was lost when retrans- mitting the last block of data in response to an NAK.
028	739268		None	Comp 3277 ECA 038	Opt		13530			None			Logic update for 3277.

Figure 2-3 (Part 2 of 5). 3271 Model 1 and 2 EC Cross-Reference Chart

### 3271 Model 1 and 2 EC Cross-Reference

This chart (Figure 2-3) is to be used to determine the need for any of the optional EC changes and to verify the EC level of any machine. To aid in determination the serial number that implemented each change is listed. This list will be updated periodically. It is recommended that a copy of this service aid be kept in 3270 card caddies.

ECA	EC	REA	Pre-Req ECA	Concur or Comp	Opt/Mand	Feature Affected	Break In Serial #	Cards Affected		Board Wiring Involved	Card Loc	Card Type	Description
								Old P/N	New P/N				
001	716954			None	Mand		10057						Factory installed on all machines.
002	717482			None	Mand		10057						Factory installed on all machines.
003	717489		3277 ECA 002 3284 ECA 003	None	Mand		10152	8521834 8522007	8522138 8522141	Yes	A1N2 A1S4	2219 L510	Correct device adapter card for addressing more than four devices.
004	717949		ECA 004	None	Mand		10152	8522119 8522009	8522152 8522139	Yes	A1J2 A1K2	9129 2221	Correct spurious Device-Ends, separate generation of device-ends and attention, add metering-in when printing.
005	717956		ECA 004	None	Opt		10666	8521725 8522138	8522830 8522831	Yes	A1E2 A1N2	2218 2219	Fixes "Read Modified" with tagged attribute in last buffer location with untagged attribute preceding.
006	718544		ECA 004	None	Mand		10666	8522129	8522839 or 8522834	None	A1H2	2220	Loss of data in position 0 with tagged attribute in last buffer position.
007	718942		ECA 004	None	Opt		10666	8521829	8522861	None	A1C2	9128	Composite EC to prevent hang on Read Modified command if there is an untagged attribute in last buffer position and no other attributes in buffer.
008	718552		ECA 004	None	Mand	ASCII	10728	8521852 8521447	8522845 8522849	None	A1M2 A2G2	9033 9110	ASCII conversion problem (ASCII machines only)
009	717949C		ECA 004	None	Mand		10847			None			Update Socket List
010	718947		ECA 004	None	Opt	EBCDIC ASCII	11109	8521443 or 8521712 8521448	8522868 8522869	None	A2E2 A2E2	9041 9111	"Line Hit" on message to 3271 results in retransmission which may result in wrong Ack. Expected Ack 0, received Ack 1.
011	718956		ECA 004	None	Opt W T C only		11109						World Trade only
012	718335			None	Mand		11443			None			Update IR Code Guide
013	718556		None	None	Mand					None			Provide 3277 "Max Pack" logics to early ship control units.
014	738897		None	None	Mand		11659			None			Prevent burning of 5 volt return line connectors
015	738790		None	None	Mand		12571			None			Connector spring clip installation

Figure 2-3 (Part 1 of 5). 3271 Model 1 and 2 EC Cross-Reference Chart

ECA	EC	REA	Pre-Req ECA	Concur or Comp	Opt/Mand	Feature Affected	Break In Serial #	Cards Affected		Board Wiring Involved	Card Loc	Card Type	Description
								Old P/N	New P/N				
029	740398		004	None	Opt		15917	8523655	8526057	None	A1L2	9085	Corrects a timeout condition that results when an internal buffer error (data check) occurs. This appears when running OLT FLT's to the 3271. Routines 46 and 53 fail. These routines do a "force buffer parity" which causes the 3271 to generate an internal buffer parity error. The printout states that the data check was received but an error occurred in retrieving the diagnostic read trace latch data. Another symptom is that with the SIU plugged in, there are no sequence indicators on.
030	740373 741298		None	None	Mand			None	None	None			Provides additional secondary circuit protection in case of power fault condition by adding a +5 volt fuse.
031	740389		None	None	Mand			None	None	None			3277 Logic Manual update
032	740036	06-81644*	004	None	Opt		15823 14070	8523640 8523658 Same	8523662  8526047 MR	Yes  None on REA 06-81644	A2B2	9045	1. Bit shifting problems due to cable crosstalk. Symptoms: Line drop, loss of control unit from polling list, timeouts.  2. Data shifting seimens D2400S MODEM (Germany) *REA - card only One wire add to complete EC
033	740861	06-81652	032	None	Opt		17069	8523645	8526059	Yes	A2E2	9041	Wrong Ack response after single or multiple line hit. Ack response latch changes only on receipt of good BSC.
034	741253	06-81666	004	None	Opt		17895	8521865	8527295		A2F2		Allow 3271 to resend the previous block of text after it has timed out and received the wrong Ack from the TCU

Figure 2-3 (Part 3 of 5). 3271 Model 1 and 2 EC Cross-Reference Chart

ECA	EC	REA	Pre-Req ECA	Concur or Comp	Opt/Mand	Feature Affected	Break In Serial #	Cards Affected		Board Wiring Involved	Card Loc	Card Type	Description
								Old P/N	New P/N				
035	384010			None	Opt WTC Only								World Trade Use Only
036	384011			None	Opt WTC Only								World Trade Use Only
037	742203			None	Opt WTC Only								World Trade Use Only
038	742201	0682457	018	None	Opt		19110			Yes			<ol style="list-style-type: none"> <li>1. Corrects a copy protected operation that erases protected data.</li> <li>2. Adds a reset to the priority counter for SDLC off-line operations.</li> <li>3. Prevents intermittent dropping of bytes of data on a write (with no error indication)</li> </ol>
039	744142	0682543		None	Mand		21895						Update logic and history. ALDs are provided to incorporate REA 0682543.

Figure 2-3 (Part 4 of 5). 3271 Model 1 and 2 EC Cross-Reference Chart

ECA	EC	REA	Pre-Req ECA	Concur or Comp	Opt/Mand	Feature Affected	Break In Serial #	Cards Affected		Board Wiring Involved	Card Loc	Card Type	Description
								Old P/N	New P/N				
040	742871			None	Opt	EBCDIC ASCII	21311	8527912	8527990	No	01BA1E2	2173 2171 2169	<ol style="list-style-type: none"> <li>1. An abort caused by seven 1-bits occurs between flag detect and SDLC command stored; a reset should have occurred.</li> <li>2. 5-volt fuse blows; request to send comes on erroneously.</li> <li>3. Possible for the I/O req to be loaded and reset at the same time.</li> <li>4. Katakana machines read commands are terminating incorrectly and losing data.</li> <li>5. Problems with both dedicated printer and integrated modem feature together in a machine, resulting in long turnaround delays and sending two command sequences simultaneously.</li> </ol>
041	There will be no EC for this ECA.												
042	742873		032	None	Opt	Mil Spec ASCII Mil Spec	21016	8523662	8527981	None	A2B2		This ECA will not be used. Loss of +5 volts, fuse blows, causes the modem interface lead "Request to Send" to turn on solid.
043	742861		033	None	Opt	EBCDIC ASCII	21396	8526059 8523646	8527916	Yes	A2E2		<ol style="list-style-type: none"> <li>1. Correct improper "Ack" response as the result of single or multiple line hits.</li> <li>2. Correct a hang in transmit due to a data check.</li> </ol>
044	743330		004	None	Opt	EBCDIC ASCII	22577	8527295	8528256	None	A2F2		This EC supersedes EC741253 (ECA034). When the 3270 is running on a two-wire network with a modem does not allow the "Receive signal element timing clock" to run continuously.
045	744157		040	None	Opt	Mod II W/O EC 744157	24462			Yes			Correct Busy Status as a result of doing a Copy to Printer.

Figure 2-3 (Part 5 of 5). 3271 Model 1 and 2 EC Cross-Reference Chart

## 3271 SERVICE AIDS

### Cables and Connectors

#### Cabling Error

On some 3271 Control Units there may be an error in the placement of a cable into the H3 or J3 position of the A2 board. Proper cable and card plugging is as follows:

1. 3271 Control Units with 1200-bps feature: A card is required in positions A2H4 and A2H5, and a cable is required in position A2H3.
2. 3271 Control Units with 2000 or 2400-bps feature: Only a cable is required in position A2H3.
3. 3271 Control Units with 4800-bps feature: A card is required in positions A2J4 and A2J5, and a cable is required in position A2J3.

#### Coaxial Cable Ends – Loose

The metal ends of unused coaxial cables that are left in the 3271 Control Unit can contact the exposed pins of the A2 board, resulting in possible component damage. Ensure that the unused coaxial cables are secured in such a manner that there is no possibility of contact with the A2 board.

#### Flat Cables – Defective

If a flat cable (cable group PN 2570156) between the A1 board and the A2 board in the 3271 Control Unit is suspected as being defective, then another cable from that board may be substituted. These flat cables are pin-for-pin compatible, but are different in length. A temporary cable (PN 5803892) is also available for use in troubleshooting a cable problem in the 3271. It is 60 inches (1.52 m) long and is pin-for-pin compatible with the cable group found in the 3271.

#### Voltage Jumpers – Defective

The exposed metal ends of some voltage jumpers can cause shorts or cold flows when installed on the back of the A1 and A2 boards of the 3271 Control Unit. These defective voltage jumpers have exposed metal ends due to the insulation being cut too short. If the jumper is installed on the board with excessive pressure, it is possible that the jumper will penetrate the insulation on an adjacent yellow wire or land pattern, causing a short or cold flow problem.

### Cards and Boards

#### Card Removal and Insertion

Power must be turned off when removing or inserting cards in the 3271 Control Unit. Analysis of returned defective cards indicates that a possible cause of failure was removing or inserting cards with power on.

#### Test Point – Serial Clock Transmit (SCT)

In the 3271 Control Unit, logic card PN 8523662 no longer has a Serial Clock Transmit (SCT) test point available at pin location A2-B2B03. This point, when probed, will appear as a floating level. To check for SCT pulses, probe A2-B2B04.

### Modems and Lines

#### Line Errors – Engineering Changes (ECs)

There are presently eight engineering changes (EC) available that should be installed to correct problems such as line drops resulting from line hits. Problems that may be corrected by these ECs are:

1. Line drops.
2. A control unit being dropped from the polling list.
3. Unrecoverable errors.
4. Time outs.

5. Loss of SYSTEM READY on the 3271.
6. Incorrect ACK responses.

The ECs are accompanied by "break in" serial numbers to help determine which ECs are needed for a particular machine. The 3271 card socket listing (A1115 and A1125) should also be consulted to determine which ECs were factory-installed. All ECs have been released to the field and must be ordered via a MES. These ECs are:

ECA Number	EC Number	Break-In Serial Number
018	739540	12672 Mandatory and auto shipped
019	739278	13462 Card A1E2 PN 8524319
026	739559	14220 Card A1B2 PN 8523659
027	740022	13969 Card A1C2 PN 8524587
029	740398	15917 Card A1L2 PN 8526057
032	740036	14070 Card A2B2 PN 8526047 (MR) or 8523662 (BW)
034 replaces EC	741253 740024	14366 Card A2F2 PN 8526054 (MR) or 8527295
033	740861	15124 Card A2E2 PN 8526059 and BW

#### Modem or Line Scoping Procedure

The following procedure can be used to verify line or modem problems:

1. Power off the 3271 Control Unit and one 3277 Display Station (Device 0) and connect the SIU for offline use.
2. Power on the 3271 and the 3277.
3. Perform an Initial Selection routine, including the ACK 0 response.
4. Perform a Read Modified command. When the text message response to the Read Modified command is complete, reply with a wrong ACK response (ACK 0) as shown below:

```

32 32 10 70 FF (EBCDIC)
16 16 10 P30 P7E (ASCII)

```

5. The 3271 will respond to the wrong ACK with an enquiry sequence as shown below:

```

55 32 32 2D (EBCDIC) for 2400, 4800, and 7200 bps speed rate.
55 16 16 P5 (ASCII) for 2400, 4800, and 7200 bps speed rate.

```

*Note:* If the speed rate is 1200 bps, the above sequence will have 3 starting pad characters (55) preceding the message instead of 1.

6. Place the SIU ONLINE/OFFLINE switch to ONLINE. The 3271 will now send the enquiry sequence down line to the TCU at the system site every 3 seconds, if the TIMEOUT OVERRIDE switch on the SIU is placed in the NORMAL position.

*Note:* For continuous transmission, install a jumper from pin A2-B2J13 to ground (D08).

7. Scoping can now be performed at the TCU for the correct enquiry sequence from the 3271. Examples of scoping patterns are shown below:

EBCDIC pattern every 3 sec from 3271 to TCU

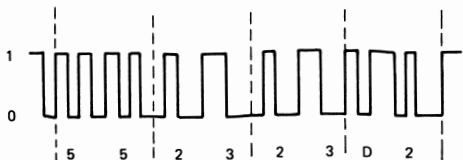

ASCII pattern every 3 sec from 3271 to TCU

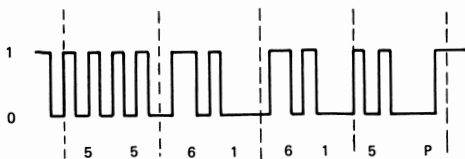

*Note 1:* Data bytes appear to be reversed. This is normal because of the shifting of the SERDES shift register in the 3271 Control Unit.

*Note 2:* Time base settings for the scoping procedure are as follows:

1200-bps rate	5 ms per division
2000-bps rate	2 ms per division
2400-bps rate	2 ms per division
4800-bps rate	1 ms per division
7200-bps rate	5 ms per division

## Programming

### Device End – Lost

If a line hit occurs while sending the Device End response to a Specific or General poll, and the program decides to poll again, the Device End condition in the 3271 Control Unit will be lost. This problem has been fixed by a change to BTAM. This change sends one NAK as a result of the TCU timeout before responding to the poll. It is recorded under OS-BTAM APAR 66416. The DOS APAR is DX01437, applicable to release 27.1. The DOS-VS APAR is DY04583.

### 8000-bps Problem – System 3

A problem can occur when a 3271 Control Unit is attached to a System 3 CPU with the 8000-bps feature. An Operations Check (OC) occurs because the 3271 cannot accept the data fast enough and data is lost. This problem occurs when:

1. The customer program has a reset Modified Data Tag (MDT) in the Write Control Character (WCC).
2. The cursor position, at the time the write is performed, is at the end of the 1920-character display (position 1919).

To correct this problem, obtain APAR number S304679. This APAR is applied against three modules (SCC4DF, SCC4DE, and SCCPDF) of the display format facility (DFF) program. This is an IBM-written program that takes the customer's data stream and formats it to run on the System 3. The APAR adds three SYN characters after a WCC with a reset Modified Data Tag bit set. Additionally, three SYN characters are added after an Insert Cursor order.

## Power Supplies

### Heat Sink Short to Ground

Check to see that the heat sink (PN 2582955), mounted in the 3271 Control Unit power supply, does not contact the screw used to connect the prime power box to the rail. If this condition is present, a short will occur. The short may show the following symptoms:

1. The primary fuse may blow.
2. Terminals 5, 6, and 7 of the power input connector may burn.
3. The 5V rectifiers or the wire to the rectifiers may fail.
4. High ac ripple on the 5V output.

The above condition can be corrected by adjusting the heat sink mounting.

### +5V Fuse

When EC 740373 (fuse change) is installed on 3271 Control Units, blowing the +5V fuse will cause Request-to-Send to come up solid on the EIA interface. This could cause an entire teleprocessing line to hang or be removed from the polling list. When this problem occurs, all indicators on the 3271 Control Unit operator panel will be off.

*Note:* EC 742873 will correct this problem.

## Tools and Test Equipment

### SIU - Byte Mode Failure

Byte mode problems (pressing the SINGLE STEP pushbutton more than once to enter a character) may occur when using the SIU on the 3271 Control Unit. To correct the problem, add a 1000-ohm resistor from A2-B2D04 to D08 (ground).

*Note:* This resistor must be removed to operate online.

### TDAT - Tape Speed

Problems with 3270 pre-recorded tape playback on all 1200 TDATs can be identified and adjusted using the MST 1 card PN 8233270. This card will identify such playback problems as head alignment, speed variations, idler roll tension, wow and flutter, and weak tape signals. The recorder in the TDAT should be adjusted using the Maintenance Library manual (S226-3029) and the Norelco\* tape recorder manual. When properly adjusted, the error light should blink less than once every 2 seconds (use the 3270 pre-recorded test tape "Speed routine").

*Note:* Test tapes having a suffix of -0 should not be used.

### TDAT and Cassette Tape Checkout

If problems are experienced using the 1200 TDAT with the 3270 system, the following aids may help determine whether the problem is with the cassette tape, the recorder, or the TDAT. Make the measurements on the TDAT EIA/CCITT connector using pin 7 (signal ground) as a reference.

1. A reading of -1V to -3V on pin 15 means that the transmit clock is running and symmetrical. This allows for 30% distortion.
2. A reading of -1V on pin 17 means the receive clock is running and symmetrical. Additional testing is required to determine if the clock is in sync with the data. Zero volts on either clock indicates a defective clock.

\*Trademark of North American Philips Company, Inc.

3. Use the 3270 test tape "speed test routine" to create a signal. If the following voltages are seen on pin 3 (receive data), then the tape and recorder are working properly.

	Terminal Attached	Terminal Unattached
Speed pattern running	+5V	+7V
Pattern not running	-10V	-12V

*Note:* Prior to making these voltage checks, the head alignment test should have been performed using the test tape (PN 2728138), and the speed of the tape player should have been properly adjusted.

EIA Line Name	EIA Pin No.	3271 Pin No.
Protective Ground	1	
Transmit Data	2	B2D02
Receive Data	3	B2M10
Request to Send	4	B2B02
Clear to Send	5	B2B09
Data Set Ready	6	Not Used
Signal Ground	7	B2D08
Carrier Detect	8	B2U04
Serial Clock Transmit	15	B2S08
Serial Clock Receive	17	B2M12
Data Terminal Ready	20	B2B13

3271 IO Connector

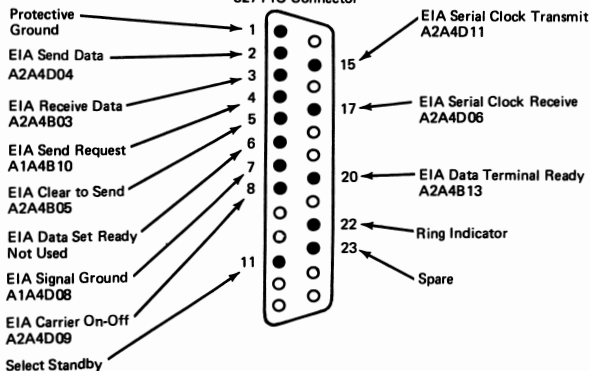

25-Pin Connector Mounted on 3271

*Note:* Signals from data set to 3271 measure +3V to +25V for up level and -3V to -25V for down level. Signals to data set from 3271 measure +3V to +8V for up level and -3V to -12V for down level.

Protective ground pin 1 does not pick up ground from 3270.

Protective ground is the cable shield and is clamped to the 3270.

**CAUTION:** When measuring voltages on the IO connector, use an oscilloscope. Do not use the General Logic Probe or the standard probe.

## Section 3. 3272 Control Unit

### Contents

<b>3272 Symptom Fix List</b> . . . . .	3-3
<b>3272 Card Substitution List</b> . . . . .	3-10
Basic Unit . . . . .	3-10
Feature or RPQ Units . . . . .	3-12
3272 Common Board Part Numbers . . . . .	3-12
<b>3272 Model 1 and 2 EC Cross-Reference</b> . . . . .	3-13
<b>3272 Service Aids</b> . . . . .	3-16
Loose Coax Aids . . . . .	3-16
Probe Points for Monitoring PT2 or B-TDAT . . . . .	3-16

### Figures

Figure 3-1. 3272 Control Unit Data Flow . . . . .	3-7
Figure 3-2. 3272 Buffer Storage Address Control . . . . .	3-8
Figure 3-3. 3272 A-Gate Card Layout by Function . . . . .	3-9
Figure 3-4. 3272 Model 1 and 2 EC Cross-Reference Chart (3 parts) . . . . .	3-13



## Section 3. 3272 Control Unit

Figures 3-1 through 3-3 give the locations for the 3272 Control Unit.

### 3272 SYMPTOM FIX LIST

The following Symptom Fix List is to be used to supplement the existing troubleshooting procedures in the MLTG.

Symptom	Fix
Addressing Failure with Condition Code 3 response Alternate Console wait state	Missing +5V A1P2
Busy, Status Modifier continuously set by all devices on SIU - Set by POR	A1Q2
Channel Bus Out checks	Bus Cable
Channel Control checks and IFCC 3158	EC 741251
Channel failure message when attempting to activate 3272. 3272 operates offline with SIU correctly. OLTS put CPU into loop.	A1T2
Control Check (intermittent)	Wrong type of coaxial cable
Cursor - double length, cannot clear Input Inhibited	A1G2
Data Checks and missing cursor	Missing -12V
Data Checks (Read), bad cursor address	A1P2
Data Checks on Write to any device	A1N2
Data Checks on Write, Read Command data contained 6 bit byte decoded as 3F on the bus.	Buffer card
Device Adapter failure	+8V D11 pin slip-on open
Dropping data or misplaced data on screen	EC 741779
Dropping devices off system one at a time	A1V2
Enable Failure and/or lost manual interrupts or becomes disabled.	A1V2
Erase All Unprotected failures. Failure on check Route 4, FLT routines 130 and 133. Timing out on split CSW. Expected Channel End and later, Device End. Received only Device End.	A1U2
Erase/Write command hangs channel	A1D2
Hangs 3272	A1G2
Hangs Busy-Condition Code 02. Power on Reset was the only reset.	A1D2
Hangs channel - missing Op-In TAG	A1V2
Hangs channel - 3272 TAGS Operation-Out, Select In, Channel waiting for Address-In	A1V2
Hangs channel writing to 3284/3286 attempting multiple prints.	A1U2
Hangs channel on one device	A1P2
Hangs in SIO Loop on Selector Channel - Correct operation on Multiplexer Channel. FLTs show interrupts from devices which are being tested.	A1S2
Hangs partition - SIU indication: Seq 2 on	A1E2
Hangs - SIU indication: Seq 6 on, Byte Count 0 on.	A1 Board
Hangs - SIU indication: Seq 2 on, Byte Count 1 on.	A1R2
Hangs systems - Application program. IPL is correct.	A1Q2

Symptom	Fix
Hangs system - channel red lights, Status-In, Service-Out, Unit unobtainable, Address Mismatch, Program loop with Address-Out, Status-In, and Short Busy	A1V2
Hangs system - run diagnostic to enable, do POR with ON LINE/OFF LINE switch set to ON LINE prior to POR	Wire No. 3 (online/offline switch) on A1V2S03 <u>not</u> S04
Hangs system - Request-In up from 3272 - unable to reset Device End	A1K2
Hangs system - OLTs cause system to loop	A1H2
Hangs system with Request-In and Control Unit Busy	A1T2
Hangs with Command Stored on	A1E2
Initial Selection incomplete - solid or intermittent reset. Input Inhibited on all displays	Relay K1-3 (+5V special) A1C2
Interface always disabled-Condition Code 3	A1G2, A1J2, A1K2, A1P2 Buffer Cards A1D11 5V special
Interface Control Checks	Capacitor on 01A-A2 D04 instead of on A2D03
Interface Control Checks on Write or Erase/Write	A1S2
Interface Control Checks. Hanging CPU. SIU - raise Address-out, Select-out, and Operation-In delayed 20 ms	A1P2
Interface Control Checks and unexplainable Wait States	A1S2
Interface Disable online (light on) ok on SIU	A1P2
Interface Disable indicator always on	A1G2
Interface Disable after Initial Selection	A1V2
Interrupts lost	A1H2
Intervention Required - any device	A1J2
Intervention Required on specific device	Adapter card
Multiplexer hang - missing interrupt in online mode. Operates correctly with SIU	Connection 01AY6
Offline - Pressing CLEAR key causes device to go offline	A1K2
Offline works - online fails	Enable/Disable Switch miswired
OLTs failure - FLT routine 132	A1C2
OLTs failure - FLT routines 97, 112, 113, 116, 125, 136 and Check routine	OLTs configured for 480 devices instead of 1920
OLTs appear to run fast - prints ret. code 08 Macro \$CUTEST - Mod A - Test Terminating	CDS cards missing Cols 46-53 (Lowest device address)
OLTs failure - FLT routines 44, 45, 52 Return code of OCON DPRINT Macro	A1J2
OLTs failure - FLT routine 132 - AID of 61 instead of 60 - Extra 7 Bit using SIU	A1C2
OLTs failure - FLT Routine 69	A1E2
OLTs failure - FLT Routine 89	A1L2
Order failure - decoding second byte of buffer Address Sequence	A1F2
Order failures - unable to decode orders - % printed instead of decoding 3C order	A1M2 A1D2
Poll Poll checkout hangs with Seq 2 on and Byte Count 0 or 1 on.	A1C2
Poll Poll checkout hangs with Seq 2 on and Byte Count 1 on. System reset checkout is correct.	Buffer

Symptom	Fix
Power On Reset failure with SIU. Byte Count stopping at 1.	A1E2
Print failure - 3286 fails to print online.	A1P2
Read Modify failure	A1U2
Read or Write to first display only	A1H2
Read Command data contained 6-bit byte decoded as 3F on the Bus.	Buffer
Read failure - cannot read 3277 buffer, Erase/Write is correct. Write command failed.	A1G2
Read Modify Command failure - Symptoms at command-out time: Byte Count 0 on, Pri. Ctr. Ldd. on, Seq 6 on and Control Check on. FLT failures: 91, 92, 94, 95, 96	A1G2
Request-In up solid	I/O ribbon cable
System light on CPU on solid; meter runs continuously when 3272 is attached.	A1A4
Transaction code always rejected under IMS	A1E2
Write Command fails to display or print data to devices. SIU Write ends correctly - no data written.	A1F2
Write or Read to first display only.	A1H2
Write Command fails. Read also fails. Erase/Write is correct.	A1G2



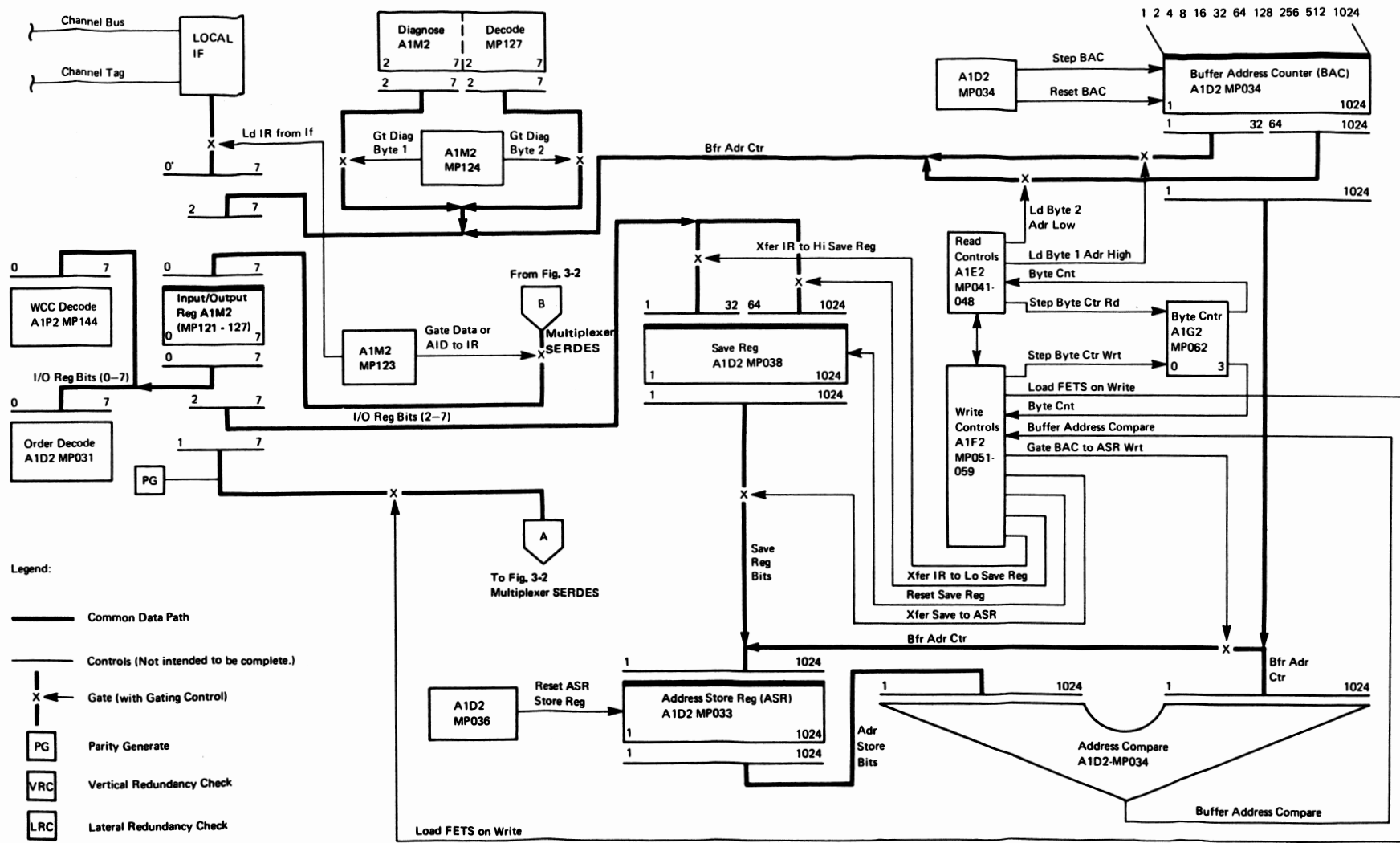
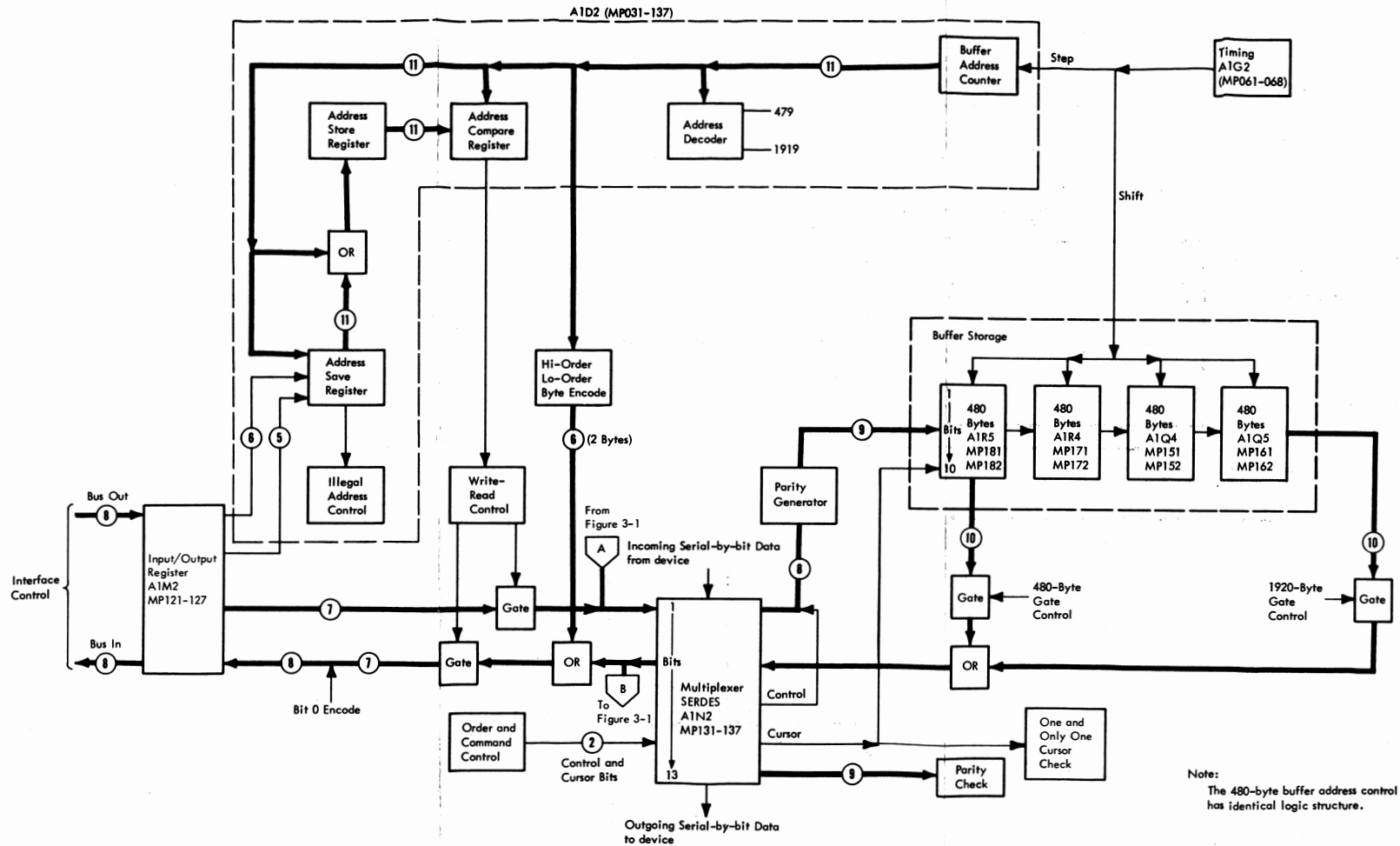

Figure 3-1. 3272 Control Unit Data Flow



Note:  
The 480-byte buffer address control has identical logic structure.

Figure 3-2. 3272 Buffer Storage Address Control

Figure 3-3. 3272 A-Gate Card Layout by Function

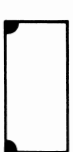
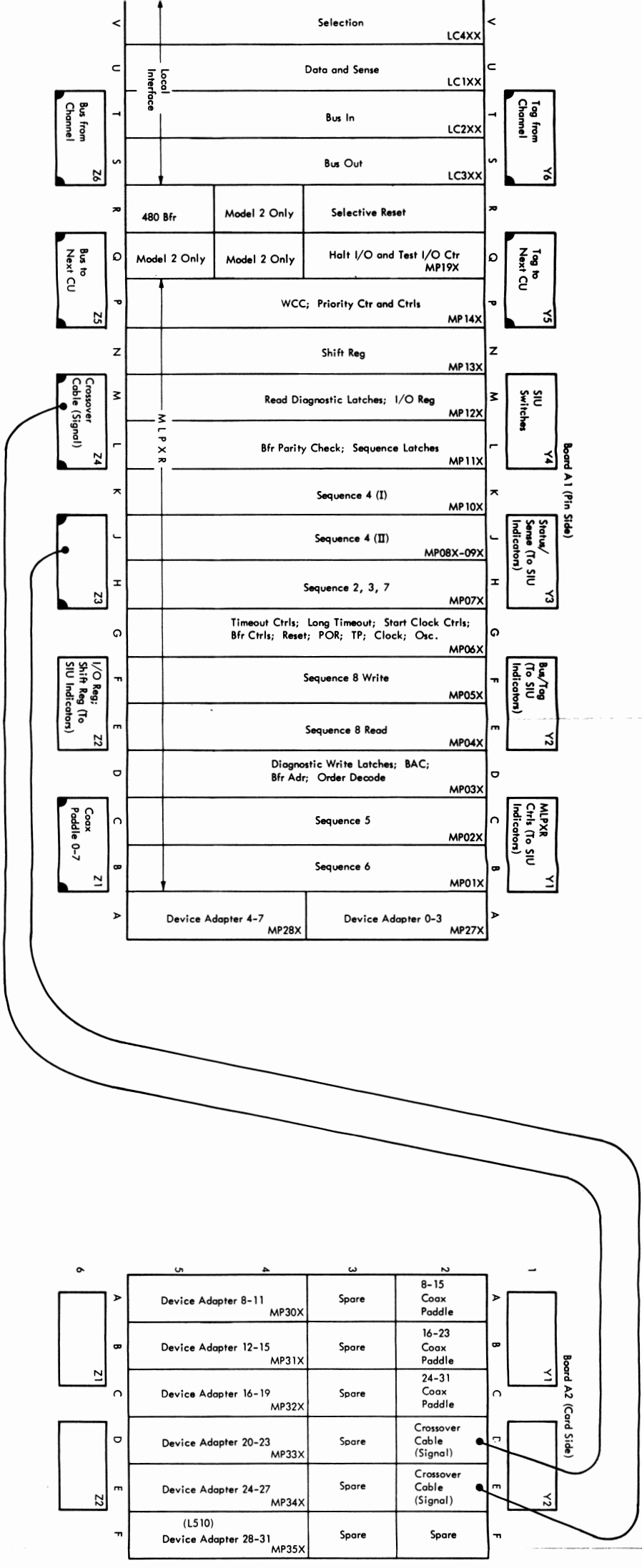

= Plugged on Pin Side

Note: Number in parentheses is card type.

**3272 CARD SUBSTITUTION LIST**

The following is a card substitution list approved only for use in the Un  
3272 Control Units.

**Key**

- FO = Factory Only
- NA = Not Available
- CC = Needs Companion Card
- BW = Needs Board Wiring
- MR = Minimum Rework - Functionally equivalent to the PN li  
below it.

The Underlined PN is the latest level card.  
Cards may be substituted up or down as long as board wiring (BW

**Basic Unit**

Loc	PN	Key	ECA/EC	Function/Comments
A1B2----	8522126	MR	003/717490	Sequence 6
	8522840		009/718542	
	8523624		020/718976	
	8523659		FO/740020	
	<u>8564141</u>		/747007	
A1C2----	8522107	MR	003/717490	Sequence 5
	8521829			
	8522841		012/718547	
	8522861		013/718943	
	<u>8524587</u>		FO/740023	
A1D2----	<u>8521716</u>		003/717490	BAC/Order Decode
A1E2----	8521725	BW,CC	003/717490	Sequence 8 RD
	8522830		006/717959	
	8524319		029/739279	
	8563022		/745479	
A1F2----	8521990	MR	003/717490	Sequence 8 WRT
	8521523		009/718542	
	8524575		031/739275	
	8527304		039/741774	
	<u>8564142</u>		/747008	
A1G2----	8521969	CC	003/717490	Clock
	<u>8523635</u>		021/738642	
A1H2----	8522129	MR	003/717490	Sequence 2, 3, 7
	8522834		007/718545	
	8522839			
	<u>8523634</u>		BW,CC 021/738642	
A1J2----	8522119	CC	003/717490	Sequence 4
	8522152		004/717950	
	<u>8522858</u>		011/718941	
A1K2----	8522009		003/717490	Sequence 4
	<u>8522139</u>		004/717950	

Loc	PN	Key	ECA/EC	Function/Comments
A1L2----	8522125 8521414 8523655 <u>8526057</u>	CC	003/717490 005/717955 FO/739554 FO/740399	BPR Parity
A1M2----	8521852 <u>8526062</u>		003/717490 035/740394	I/O Reg
A1N2----	8522138 <u>8522831</u>	CC	003/717490 006/717959	Shift Reg
A1P2----	<u>8522124</u>		003/717490	Priority Ctr
A1R2----	8523261 <u>8526064</u> *	CC,BW BW	017/718964 036/740038	IF Selective Reset
A1S2----	8522127 8522857 8523622 <u>8527906</u> *	MR,CC,BW BW	003/717490 010/718550 017/718964 043/741779	IF Bus Out
A1T2----	8521686 <u>8522149</u>	CC	003/717490 004/717950	IF Bus In
A1U2----	8522106 8522111 8522148 8522826 8522823 8522838 8523251 8522870 8523626 8523627 8523588 8524323 8526050 <u>8526970</u>	MR MR MR MR MR,CC,BW CC,BW MR	003/717490 005/717955 008/718548 015/718948 017/718964 017/718964 032/739548 FO/740395 037/741251	IF Data & Sense
A1V2----	8522113 8522150 8522835 8522862 8523263 <u>8527297</u>	CC CC,BW CC,BW	003/717490 004/717950 009/718542 010/718550 017/718964 038/740867	IF Selection
A1Q2----	8522132 8524320 <u>8526971</u> *	CC BW BW	005/717955 023/739542 040/741252	IF TIO HIO
A1R4/5	A1Q4/5- <u>8521985</u>		003/717490	Buffer
A1A2----	8521508 8522141 <u>8522147</u>	MR CC	003/717490 004/717950	Device Adapter

\*These cards may be used on U.S. machines in emergency situations without adding board wiring. If the card is to be left in the machine the CE must order and install the proper EC.

**Feature or RPQ Units**

Loc.	PN	Key	EC	No./Description
A1E2----	<u>8527903</u>		NA	APL
A1N2----	8527996		743326	APL
	8528266	MR	REA 06-82544 (743332)	APL
	<u>8528267</u>		743332	APL
A1N2----	8524283			AB4820/5000 Ft (1 524 m) RPQ
	<u>8524321</u>			AB4820/5000 Ft (1 524 m) RPQ
Adapter-	<u>8524318</u>			AB4820/5000 Ft (1 524 m) RPQ
Adapter-	<u>8527294</u>		NA	8K0566 Lightning Protection

**3272 Common Board Part Numbers**

Loc.	PN	Description
A1	2625216	Base
	2610002	50001 RPQ
	1739988	APL
A2	2625218	Base

### 3272 Model 1 and 2 EC Cross-Reference

This chart (Figure 3-4) is to be used to determine the need for any of the optional EC changes and to verify the EC level of any machine. To aid in determination the serial number that implemented each change is listed. This list will be updated periodically. It is recommended that a copy of this service aid be kept in 3270 card caddies.

ECA	EC	REA	Pre-Req ECA	Concur or Comp	Opt/Mand	Feature Affected	Break In Serial #	Cards Affected		Board Wiring Involved	Card Loc	Card Type	Description
								Old P/N	New P/N				
001	716956				Mand	Base	30081						No Field Bill
002	717483				Mand	Base	30081						No Field Bill First Customer Ship Level
003	717490				Mand	Base	30173						These ECs were shipped to all machines to establish 'C' exit level.
004	717950				Mand	Base	30203						
005	717955				Mand	Base	30203	8522125 8522106 or 8522111	8522132 8521414 8522823	Yes	A1Q2 A1L2 A1U2	X459 9095 9046	Add new card to Q2. Correct T10 problem.
006	717959		717955		Opt	Base	30804	8521725 8522138	8522830 8522831	Yes	A1E2 A1N2	2218 2219	Corrects Rd Mod with tagged attribute in last buffer location.
007	718545		717955		Mand	Base	30804	8522129	8522834 or 8522839	None	A1H2	2220	Loss of data in buff location 0 with tagged attribute in last buffer location.
008	718548				N/A	Base	30843						No Field Bill. Became part of 718964
009	718542				N/A	Base	30804						No Field Bill. Became part of 718550
010	718550		717955		Mand	Base	30804	8522127 8522150	8522857 8522862	Yes	A1S2 A1V2	9048 9049	IFCL. Spurious I/O Interrupts
011	718941		717950		Mand	Base	30804	8522152	8522858	None	A1J2	9129	SIO to busy device does not receive busy in initial status
012	718547				Opt	Base	30843						No Field Bill. Became part of 718943
013	718943				Opt	Base	30843	8521829	8522861	None	A1C2	9128	Hang on Rd Mod untagged attribute in last buffer location and no other attribute in buffer.
014	7179552												Update Socket List
015	718948												No Field Bill. Part of 718964
016	718335												IR Code Guide

Figure 3-4(Part 1 of 3). 3272 Model 1 and 2 EC Cross-Reference Chart

ECA	EC	REA	Pre-Req ECA	Concur or Comp	Opt/ Mand	Feature Affected	Break In Serial #	Cards Affected		Board Wiring Involved	Card Loc	Card Type	Description
								Old P/N	New P/N				
017	718964		718550		Mand	Base	31420	8522857 8522823	8523261 8523622 8523626 or 8523627	Yes	A1R2 A1S2 A1U2	Y931 9048 9046	Short read on Rd Mod. False chain on 2880. Chain cannot be broken. CU reset. Multiple chain end. Sends sys avail at wrong time. Add R2 card.
								8522862	8523263		A1V2	9049	
018	718556				Mand								3277 logic.
019	738897				Mand	Base	31604						5V return.
020	718976		717955		Opt	Base	31691	8522840	8523624	None	A1B2	2216	Ctrl cks under DIDOCS.
021	738642		718964		Opt	Base	32185	8521969 8522879	8523635 8523634	See Description.	A1G2 A1H2	9036 2220	Timing for 3115-3125. Wiring done on 718964.
022	738790				Mand	Base							Connector clips.
023	739542		718964		Mand	Base	32775	8522132	8524320	Yes	A1Q2	X459	IFCC address mismatch printer on 2860.
024	738794				Mand								Pwr supply logic.
025	739065				Mand								3277 logic.
026	739072				Mand								
027	718969				Mand								
028	739071				Mand								
029	739279				Mand								
			717959		Opt	Base	33276	8522830	8524319	None	A1E2	9039	Loss of SBA on light pen interrupt.

continued on next page

Figure 3-4 (Part 2 of 3). 3272 Model 1 and 2 EC Cross-Reference Chart

ECA	EC	REA	Pre-Req ECA	Concur or Comp	Opt/ Mand	Feature Affected	Break In Serial #	Cards Affected		Board Wiring Involved	Card Loc	Card Type	Description
								Opd P/N	New P/N				
30	739268			739268 for 3277	Opt								3277 logic.
31	739275	0692444	005		Opt	Base	33918	8521523	8524575	See Note	A1F2	9039	New card for F2 to correct write problem where an extra byte or attribute may be written or a data byte or attribute may be dropped. Also adds a board wire for Katakana machines. The wire and the card are not related.
32	739548	0692453					34089	8524323			A1U2	9046	The field B/M has been cancelled and will be included in EC 741251.
33	740373				Mand	Power	34997						Add fuse to +5V safety.
34	740389				Mand								3277 logic.
35	740394	0681643	005		Opt	Base	34654	8521852	8526062	None	A1M2	9033	Corrects sending an extra byte of data to the channel on a read buffer or read modified command.
36	740038	0681650	017		Opt	Base	34850	8523261	8526064	Yes	A1R2	Y931	Eliminates a hang condition when a channel program check causes the channel to issue a pseudo TIO and then stacks zero initial status.

Figure 3-4 (Part 3 of 3). 3272 Model 1 and 2 EC Cross-Reference Chart

## 3272 SERVICE AIDS

### Loose Coax Ends

A condition of possible component damage in the 3271 and 3272 Control Units could exist if the loose ends of coax cables are left uncovered in the control unit.

The metal ends of unused coax cables that are left in the 3271 and 3272 Control Units can come into contact with the exposed pins of the A2 board, resulting in possible component damage.

Ensure that the unused coax cables are secured and dressed in such a manner that there is no possibility of contact with the A2 board.

### Probe Points for Monitoring PT2 or B-TDAT

The following pins can be used for 3275 Models 1 and 2 with an undercover modem for attaching a PT2 or buffered TDAT for monitoring purposes (all probes are on the B-gate):

SCR	+SCR or SCT 1200/900 BPS	M2B11
CD	+CARRIER DETECT EIA	N4D02
RD	-RECEIVE DATA	N4D13
SCT	+SCT or SCR 1200/900 BPS	F2D12
CS	+CLEAR TO SEND EIA	M2B09
RS	+REQUEST TO SEND EIA	N2D04
SD	-SEND DATA	N2J11

Note that Receive Data and Send Data are minus levels. The minus levels on these two signals are active levels and do not have to be inverted on the PT2 or buffered TDAT.

## Section 4. 3275 Display Station

### Contents

<b>3275 Symptom Fix List</b> . . . . .	4-3
Video (Power) . . . . .	4-4
Remote Interface and Control Logic . . . . .	4-5
Miscellaneous . . . . .	4-6
<b>3275 Model 1 and 2 Card Substitution List</b> . . . . .	4-17
Basic Unit . . . . .	4-17
Other Features and RPOs . . . . .	4-21
<b>3275 Model 1 and 2 EC Cross-Reference</b> . . . . .	4-23
<b>3275 Service Aids</b> . . . . .	4-30
Line, Modem Scoping Procedures . . . . .	4-30
Probe Points for Monitoring PT2 or B-TDAT . . . . .	4-31
Version Level Feature Identification . . . . .	4-32
3275 Line Adapter Installation . . . . .	4-33
Incorrect Characters or Quote Marks on 3275 Screen with Status Light . . . . .	4-33
Field Installation of 4800/7200 BPS Feature . . . . .	4-33
+5 Fuse . . . . .	4-33

### Figures

Figure 4-1.	3275 Display Data Flow . . . . .	4-7
Figure 4-2.	3275 Remote Interface and Control Unit Data Flow, Leased Line – ASCII . . . . .	4-8
Figure 4-3.	3275 Remote Interface and Control Unit Data Flow, Leased Line – EBCDIC . . . . .	4-9
Figure 4-4.	3275 Remote Interface and Control Unit Data Flow, Dial – EBCDIC . . . . .	4-10
Figure 4-5.	3275 Remote Interface and Control Unit Data Flow, Dial – ASCII . . . . .	4-11
Figure 4-6.	3275 A-Gate Card Layout by Function (Display) . . . . .	4-12
Figure 4-7.	3275 B-Gate Card Layout by Function (Leased) . . . . .	4-13
Figure 4-8.	3275 Model 3 A-Gate Card Layout by Function . . . . .	4-14
Figure 4-9.	3275 Model 3 B-Gate Card Layout by Function . . . . .	4-15
Figure 4-10.	3275 B-Gate Card Layout by Function (Dial) . . . . .	4-16
Figure 4-11.	3275 Model 1 and 2 EC Cross-Reference Chart (7 parts) . . . . .	4-23



## Section 4. 3275 Display Station

Figures 4-1 through 4-10 give the locations for the 3275 Display Station.

### 3275 SYMPTOM FIX LIST

The following Symptom Fix List is to be used to supplement the existing troubleshooting procedures in the MLTG.

Symptom	Fix
Attributes are displayed causing Data Checks.	01A-A1C2
Cursor missing on POR. No cursor, Input inhibited and the Status indicator is on after a Power-On Reset.	01A-A1F2
Device End not set with POR. Following POR, EOT status occurs instead of DE status.	01A-A1E2
Displays non-display field.	01A-A1H2
Dot only for cursor. 3275 cursor was only a dot in the left-hand margin. As data was entered, the cursor would move and grow to normal size and was blinking. The original dot was on solid.	01A-A1H2
Extra characters on screen. After powering on, or if the machine was idle, extra characters appear on the screen.	01A-A1D2
Input Inhibit. After POR sequence, the Input Inhibited indicator turns on.	01A-A1E2
Input Inhibit. Characters change display positions, Input Inhibited and Status come on.	01A-A1J2
Input Inhibit on Power On Reset (POR). When the power is turned on, Input Inhibited and Status indicators come on.	01A-A1D2
Input Inhibited indicator is always on.	01A-A1L2
Missing DE after print 3284/3275. After a Write command to the printer, the host system did a General Poll and expected Device End. 3275 sent EOT and never sent status of DE.	01A-A1E2
Modified Data Tags not being set by keyboard. Checks out correctly with SIU.	01A-A1A2
POR problem. No Power On Reset	01A-A1G2
Print Command. Timeouts after a print command to 3284 printer with SIU attached. WACK indicator on. WACK character missing from response.	01A-A1H2
Prints line 1 of 3275 on last line of 3284. 3284 prints first line from 3275 on last line of 3284.	01A-A1L2
Screen full of D or A.	01A-A1F2
Timeouts from CPU. Tape tests run correctly.	01A-A1E2
Transmit EOT with Power On Reset. When 3275 is powered up and attached to TDAT or data set, it will start transmitting EOT continuously.	01A-A1E2

## Video (Power):

Symptom	Fix
Audible Alarm fails. Not working on 3275 or 3277.	Analog card
Blows fuse 1 immediately. 3275 blows fuse 1 immediately when power is turned on.	Analog card
Cursor disappears, Audible Alarm sounds. When not online, the Audible Alarm sounds and the cursor disappears for 20 seconds. When online, a random character is inserted where the cursor was and the Status indicator turns on.	HVPS
Cursor missing - no display. Pressing INTENSIFY OVERRIDE would cause a single line to be displayed at the top of the screen.	HVPS
Extra AID characters prior to transmission.	Decoupling capacitor on the 01B-A1 board is on D05 pin and not on D08 pin.
Input Inhibited and data checks (vibration sensitive)	LVPS card shorting against frame.
Intensity control problem. On initial power up of the 3275, the display comes on very bright. Cannot control the intensity with the intensity control.	Bad analog card
Message not displayed. Messages sent through remote interface cannot be displayed on video screen. Data keyed-in via keyboard are correctly displayed. Cable at B1Z2 with poor connection.	Reseat cable (B1Z2)
Missing 8V. 8V measures 1V. Loss of 400V on high voltage. No cursor or sweep indicator.	Loose connectors pin 10 and 11 connector.
POR sequence failure. POR sequence not correctly ended . . . no cursor displayed.	HVPS defective.
POR without delay, highly intermittent. All data in buffer is lost.	Replace voltage distribution board.
Radio interference - 3275 and 3277. There is a possibility of interference to radio receivers from the analog card due to parasitic oscillations (applies to installations such as police stations). The analog card is not defective, but replacement should correct the problem.	Replace analog card.
Raster failure. Raster always present on the screen.	Replace analog card.
Screen blanks when attaching data set cable.	Missing red insulator cap on mounting stud behind -12V regulator card. The -12V can short from frame to signal ground.
Screen goes blank. Display goes blank 5 to 20 minutes following power up. Pressing INTENSIFY OVERRIDE switch causes single horizontal line across top of screen.	Voltage distribution board. Diodes CR1, 2, 3 on defective boards might be wired backwards.
Screen image disappears. Display intermittently disappears.	HVPS
Short Turnaround - no Clear To Send (CTS). With Integrated Modem (Mini-12) the 3275 responds immediately with no Clear To Send (CTS) delay. +12V measures +22V with a load and +34V without a load.	Open dc return in cable from +12V regulator card to PC board.

## Remote Interface and Control Logic:

Symptom	Fix
ACK - incorrect or out of sequence	EC 740862 ECA 048
Bad data or no data from 3275.	01B-A1M2
Continuously resends data in buffer. When doing a read of the 3275 buffer from the SIU the 3275 resends the data on the display over and over.	01B-A1A2
Bad data transmitted	01B-A1J2
Data Check on status message of Device End	01B-A1L2
Data Checks. TCU Data Check on customer programs. No error on the 3275. It will run offline on SIU.	01B-A1L2
EOT in middle of read modified data stream.	01B-A1B2
EOT reply missing after RVI from host	01B-A1K2
Erase/Write Command failure.	01B-A1B2
ETB sent at wrong time	01B-A1H2 jumper missing
ETX invalid	01B-A1H2
Fails to send correct data. Hit any PF key, ENTER key with blank screen, or TEST REQ. with blank screen, 3275 sends: STX space space ETX.	01B-A1A2
False status (DE). When polling general or specific, status always is presented (C2 40) Device End.	01B-A1H2
General Poll failure. No response to a General Poll. Specific Poll works correctly.	01B-A1K2
Hot bit in SERDES.	01B-A1L2
Incorrect data or Data Check. Cannot send data or status correctly. Fails in Transmit only.	01B-A1L2
Incorrect data transmitted.	01B-A1H2
Incorrect response to poll. 3275 responds to poll with an AID character that should not be there.	01B-A1B2
Input Inhibited. Input Inhibited comes on during polling. Sync Search stays on and Selected turns on.	01B-A1D2
Multiple AID characters on a Read command. On a Read command multiple AID characters move through SERDES - found "Gate Aid" up all the time. For example: For an ENTER key you would get 7D 7D 7D 7D etc.	01B-A1B2
No data display on a Write. No data displays after doing a successful Write command to the screen with all the correct indications on the SIU.	01B-A1J2
No device selected or SP/GP indicator. During Specific Poll, at load of second device address, DEV SEL and SP/GP indicators fail to come on. Initial selection works.	01B-A1J2
Poll failure	01B-A1K2 jumpers
Poll failure - no response	01B-A1H2
Read Command failure	01B-A1L2
Receives correctly, will not transmit	01B-A1F2 (High bps)
Receive Failure - 3275 Integrated Modem (Mini-12). The 3275 was not able to receive with the Integrated Modem (Mini-12).	01B-A1N4
Repeat first data character on Write. On a Write command, the first data character entered will fill the screen with that character. Also a status of Op Check occurs.	01B-A1A2
Request to Send (RTS) up solid.	01B-A1L2 or A1M2
Responds with EOT to any order or command.	01B-A1G2
Specific Poll failure	01B-A1K2 jumpers
Start Pad character incorrect	01B-A1L2

Symptom	Fix
Status indicator comes on intermittently.	01B-A1L2
Status light	01B-A1H2, A1J2
Status of OP Check on Write from SIU.	01B-A1F2 (High bps)
SYN character decode problem. Unable to decode SYN characters (Hex 32). Dial feature without Integrated Modem installed. Also with Integrated Modem no dial.	01B-A1F2
Timeout -	01B-A1H2, A1K2, A1L2, A1M2
Timeout and Op Check	01B-A1F2 (High bps)
Timeouts at CPU. Symptom: (1) Using test box SERDES fills up, (2) Timeouts at host system site, (3) Sync Search indicator not flickering, and (4) no response.	01B-A1L2
Timeouts - after host system is polling, a time-out occurs. When the host system honors an enter request, it will try to get back into the poll sequence. At this time a time-out will occur. The CPU will then go on and poll correctly until the next ENTER key operation is performed.	01B-A1K2
Transmits full buffer ended with ETB. Transmits only the first character entered from the keyboard or loaded by a TCU command for the length of the buffer: Ended with ETB.	01B-A1A2
Write Command failure (no data transfer)	01B-A1M2
<b>Miscellaneous:</b>	
Symptom	Fix
Data incorrect. When numeric characters are keyed in, followed by a Read Buffer command to the 3275, instead of F1F2F3F4F5, the response is B1B2B3B4B5.	Defective cable from B1Y3 to A1Z3.
Drop AID and data-Read Command. Missing AID and data character in SERDES register on Read Modified Command. On an Erase/Write Command, the data should have started at position zero; however, the first character went to the fifth, from the last line in position 40.	Flat cable from 01A-A1Y3 to 01B-A1Z3
Incorrect data displayed. 3275 displays incorrect data in any or all positions of screen.	Insure data set is providing common pins 1 + 7.
Input Inhibited without pressing AID keys. Input Inhibited comes on unexpected while using keyboard (vibration sensitive).	Defective enter key module.
Parity error from keyboard. Keyboard parity bit is on all the time, even when character does not require one. Input Inhibited indicator comes on when a character key is pressed. Does not require a parity bit.	Resistor was wired from 01A-A1C6B04; should have been 01A-A1C6C04; after EC 718965-A resistor will be on card.
Unable to run 3275 at half duplex at 4800 bps.	New sync missing at CPU.



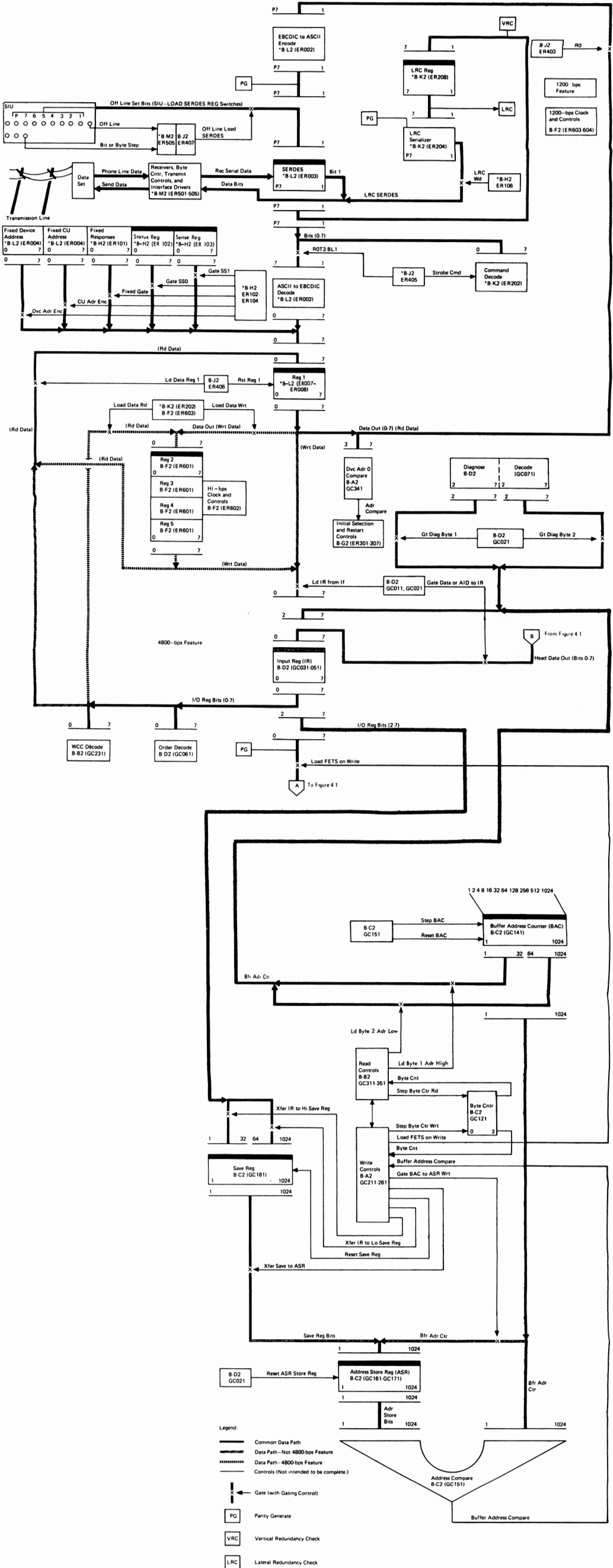

Figure 4.2 3275 Remote Interface and Control Unit Data Flow - Leased Line - ASCII

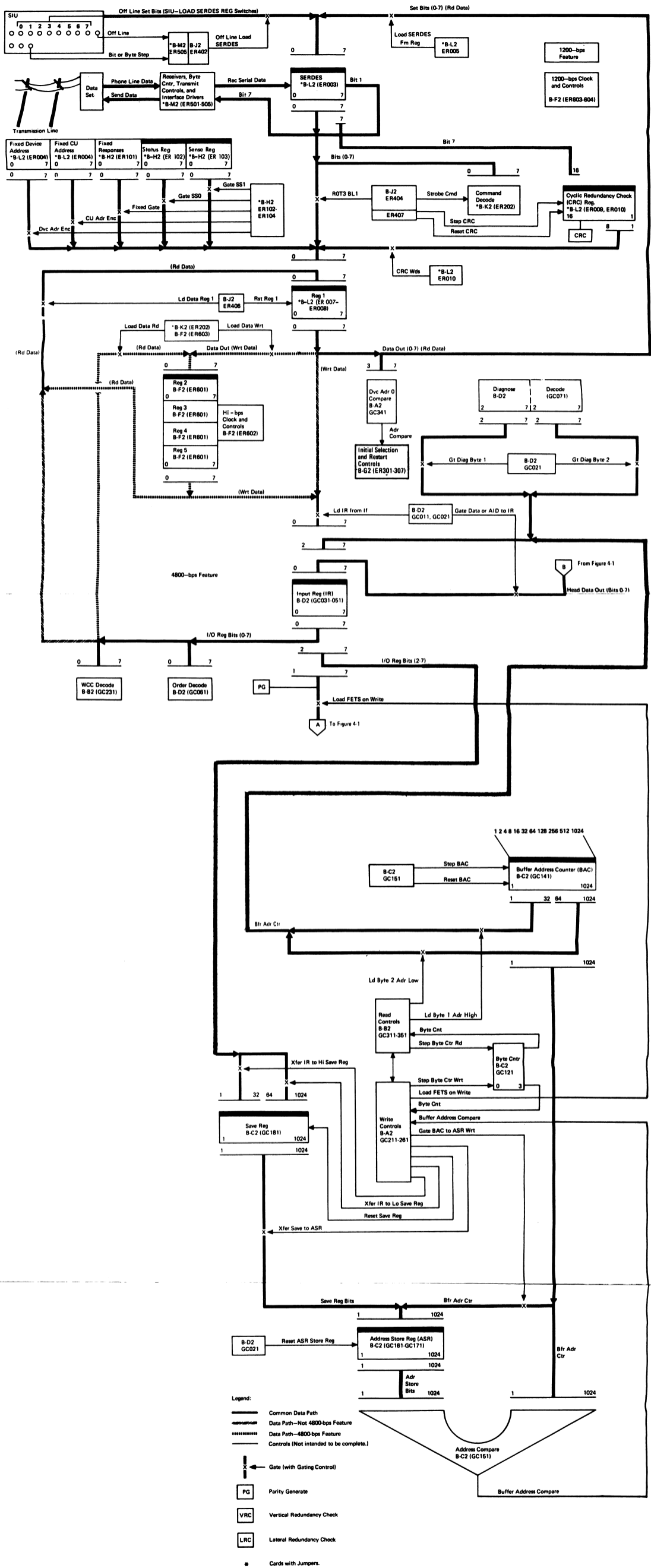

Figure 4-3. 3275 Remote Interface and Control Unit Data Flow, Leased Line – EBCDIC

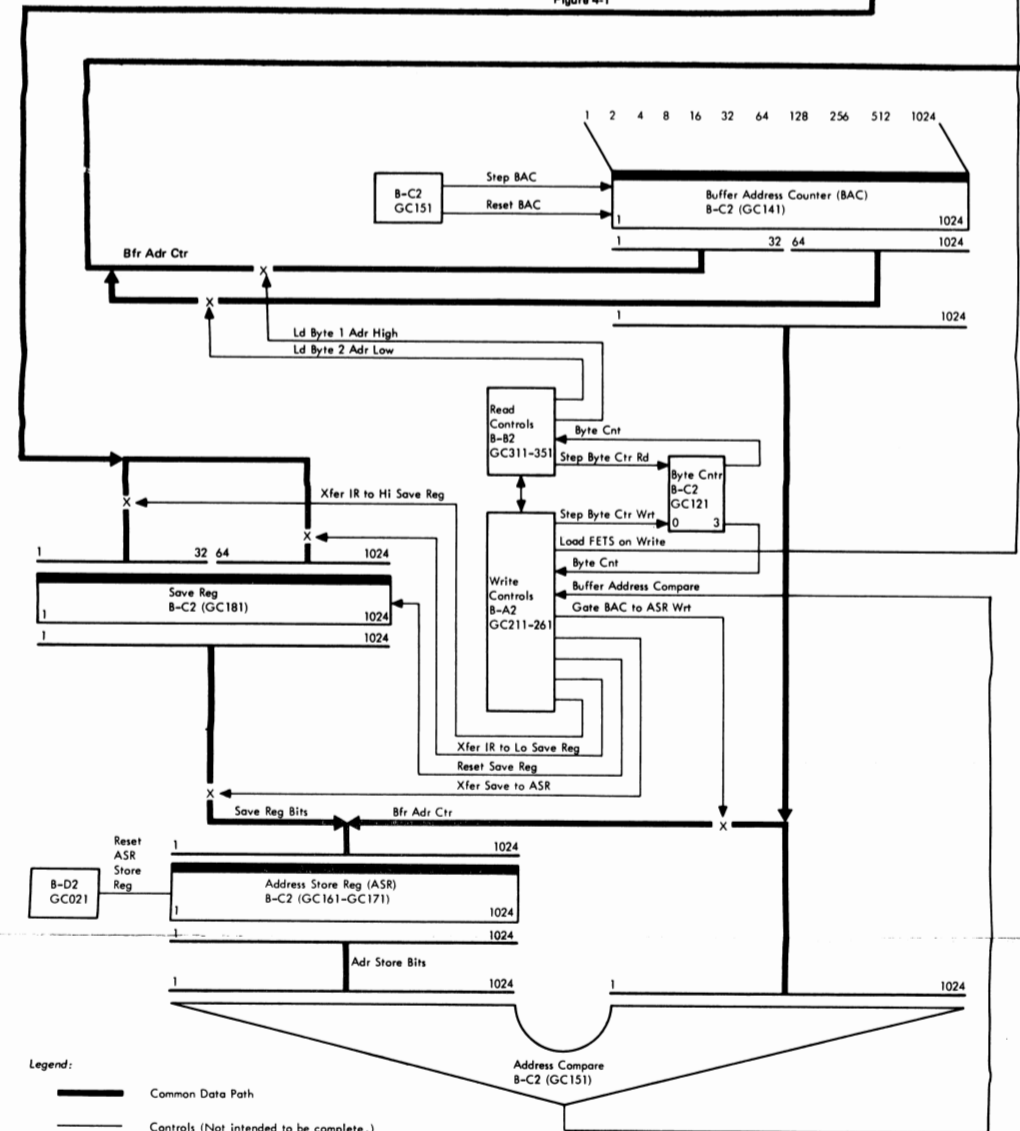
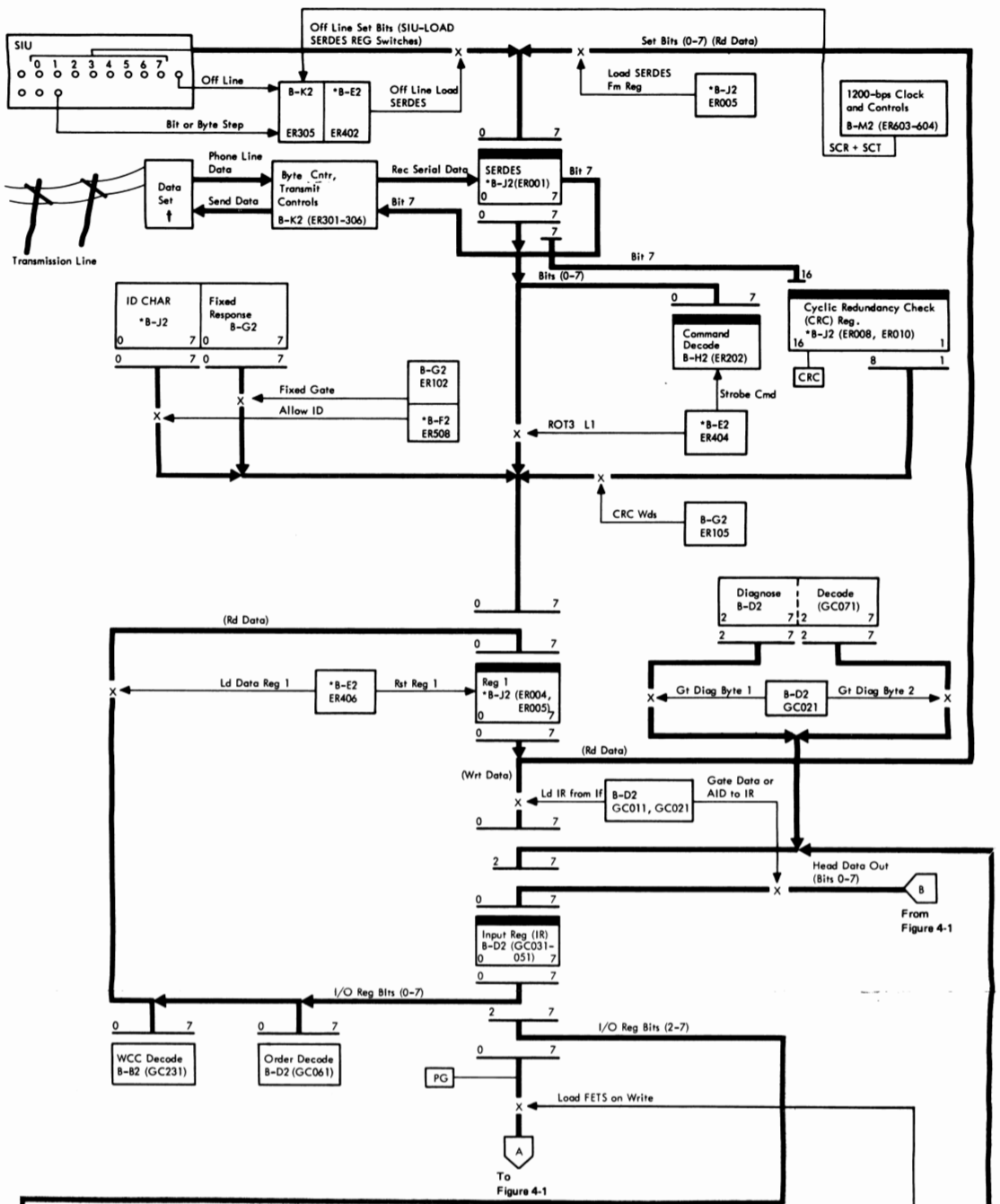
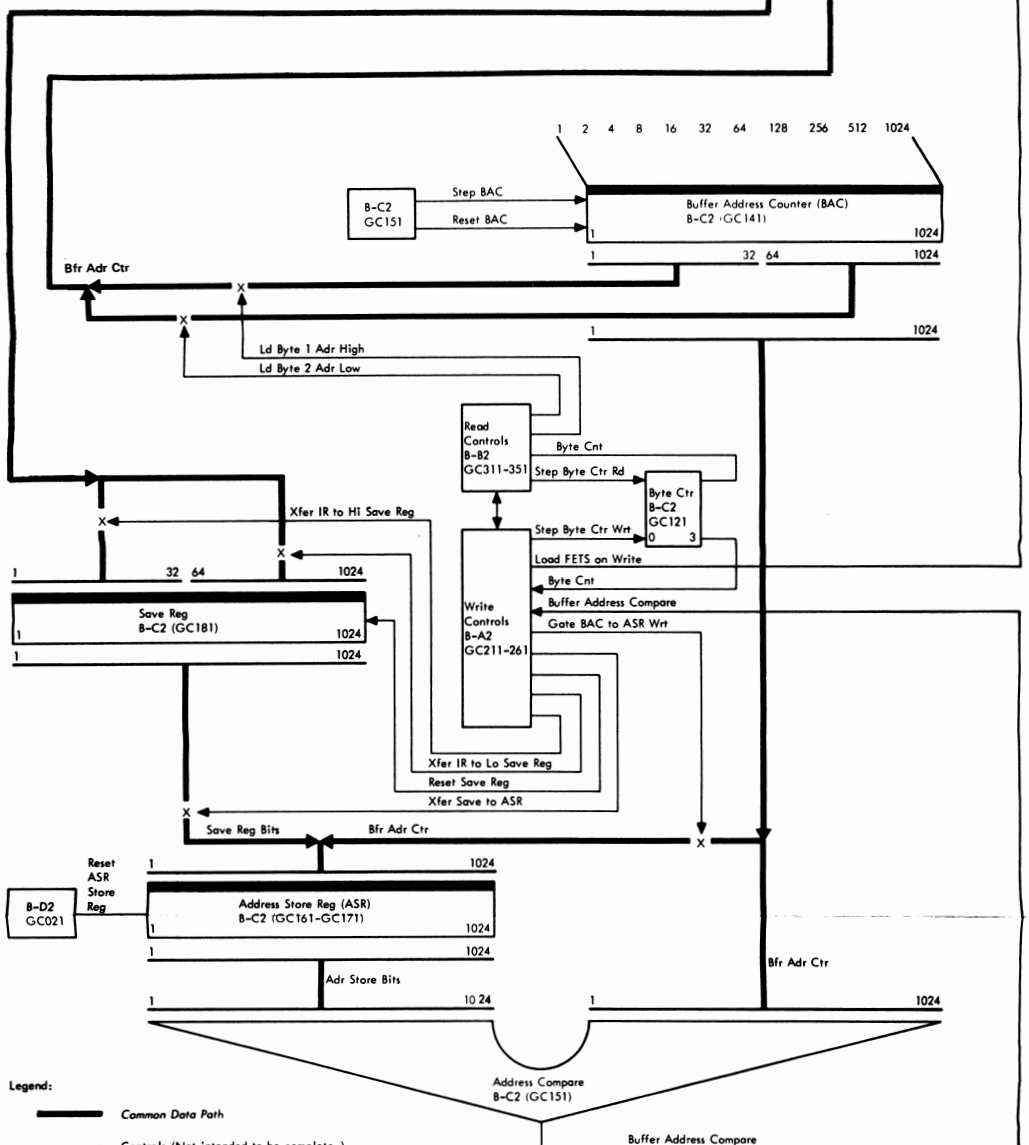
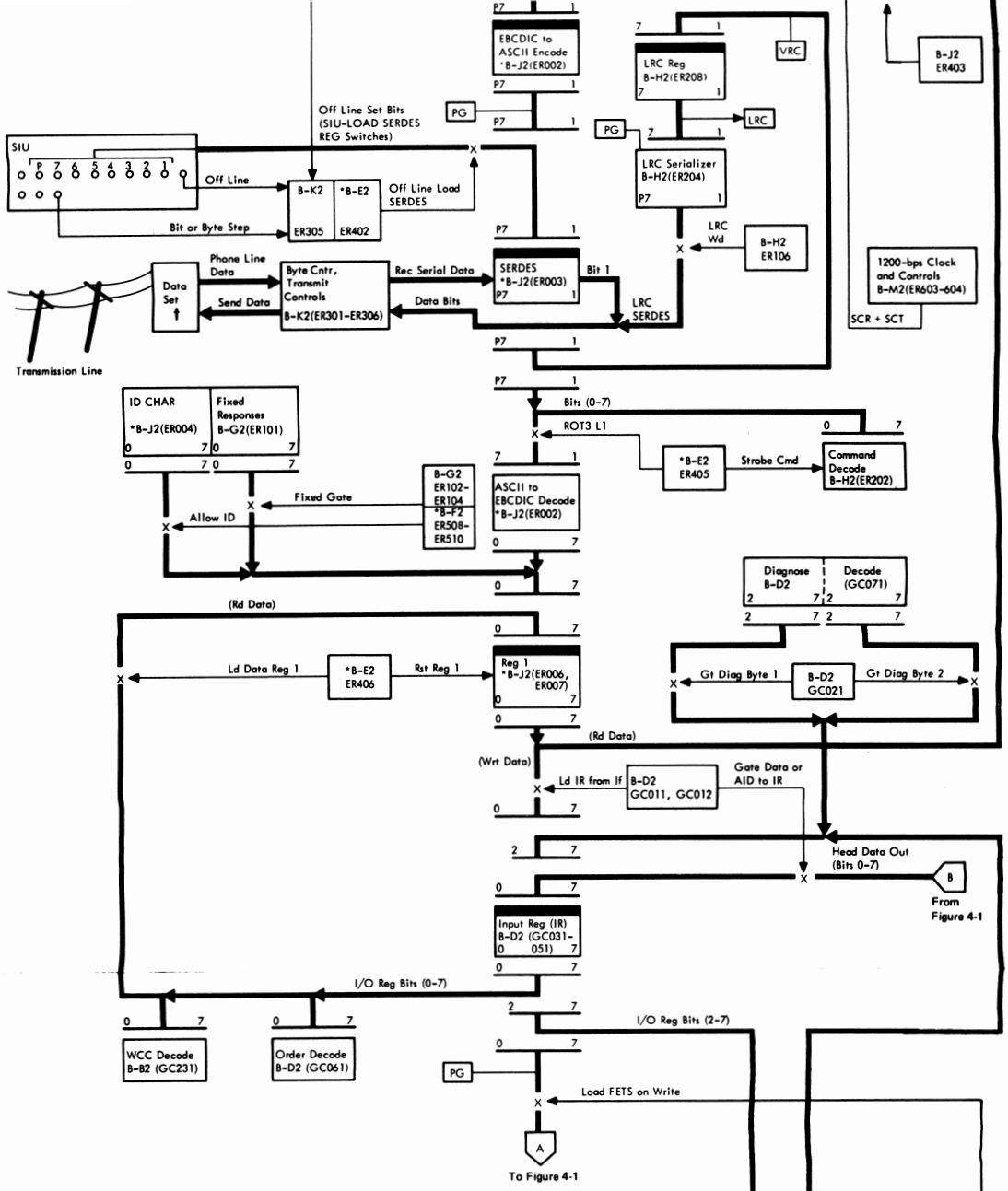

Figure 4-4 3275 Remote Interface and Control Unit Data Flow, Dial - EBCDIC



- Legend:**
- Common Data Path
  - Controls (Not intended to be complete.)
  - Gate (with Gating Control)
  - Parity Generate
  - Vertical Redundancy Check
  - Lateral Redundancy Check
  - Cards with Jumpers.
  - On Display Stations with Line Adapter Feature installed, "Data Set" consists of cards 1 in B-N2 column.

Figure 4-5. 3275 Remote Interface and Control Unit Data Flow, Dial - ASCII

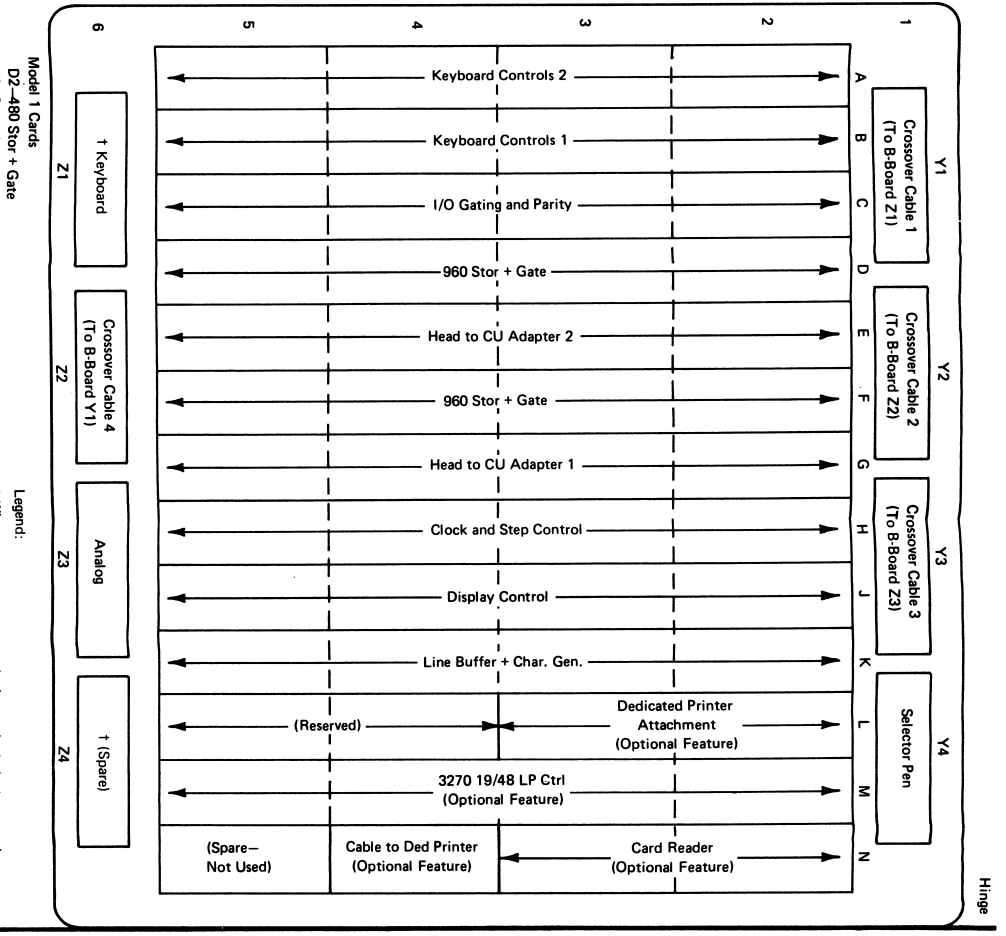
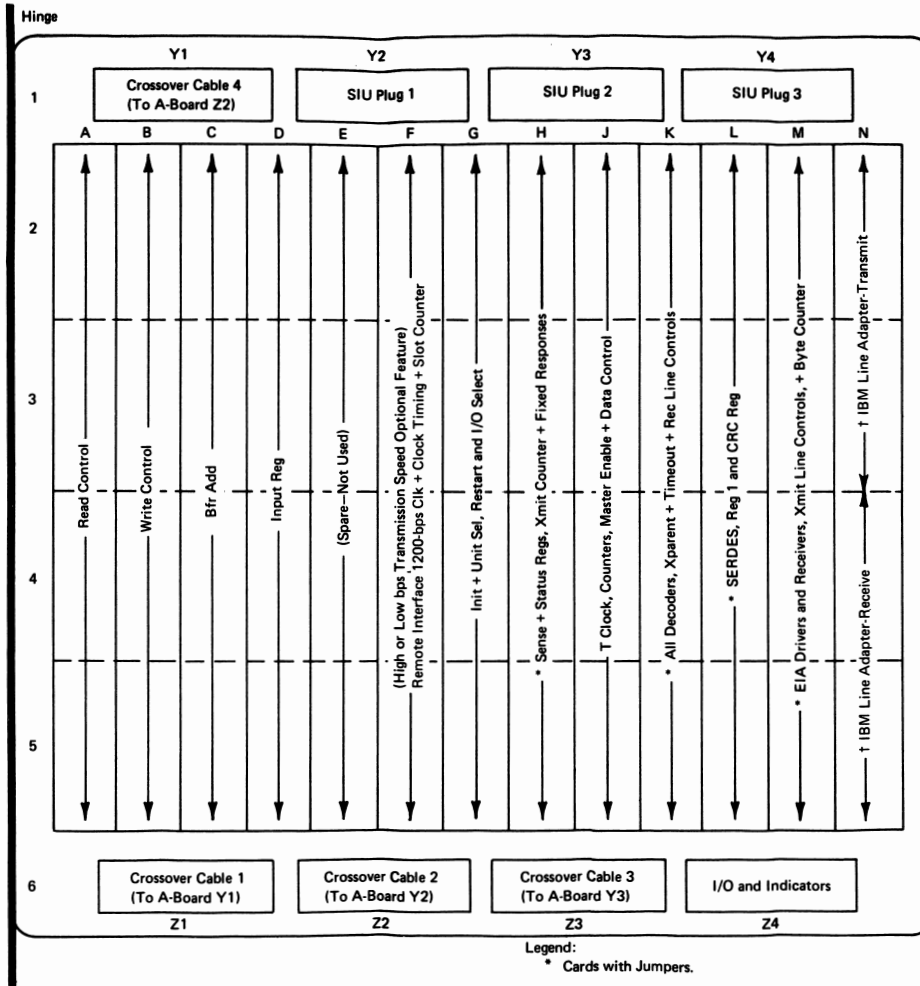

Figure 4-6. 3275 A-Gate Card Layout by Function (Display)



**ASCII Feature Cards**

- H2—ASCII Fixed Inputs Status Reg Xmit Ctr
- J2—ASCII T Clock and Timeout
- K2—ASCII Decoder and LRC Reg and LRC SERDES
- L2—SERDES and ASCII/EBCDIC Code Converters
- D2—ASCII IO Reg

**4800-bps Transmission Speed Card**

- F2—High-Baud Feature (Double card)

**Line Adapter Feature Cards**

- N2—IBM Line Adapter - Transmit
- N4—IBM Line Adapter - Receive

Figure 4-7. 3275 B-Gate Card Layout by Function (Leased)

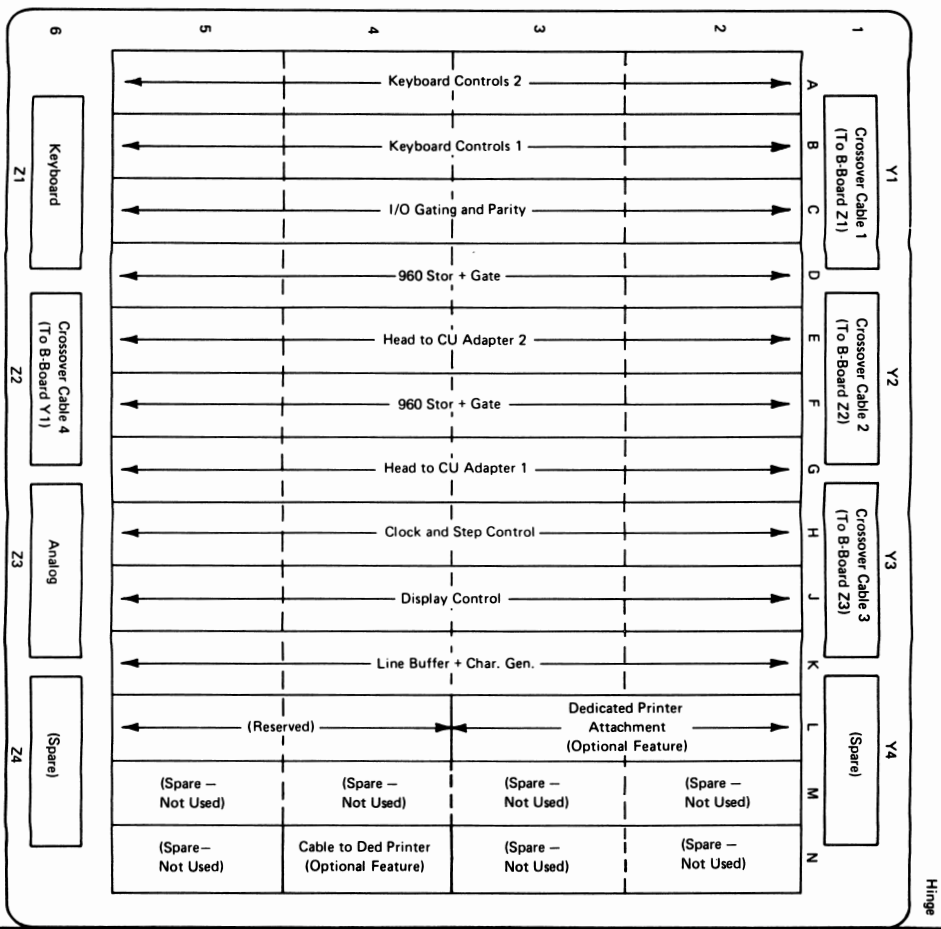
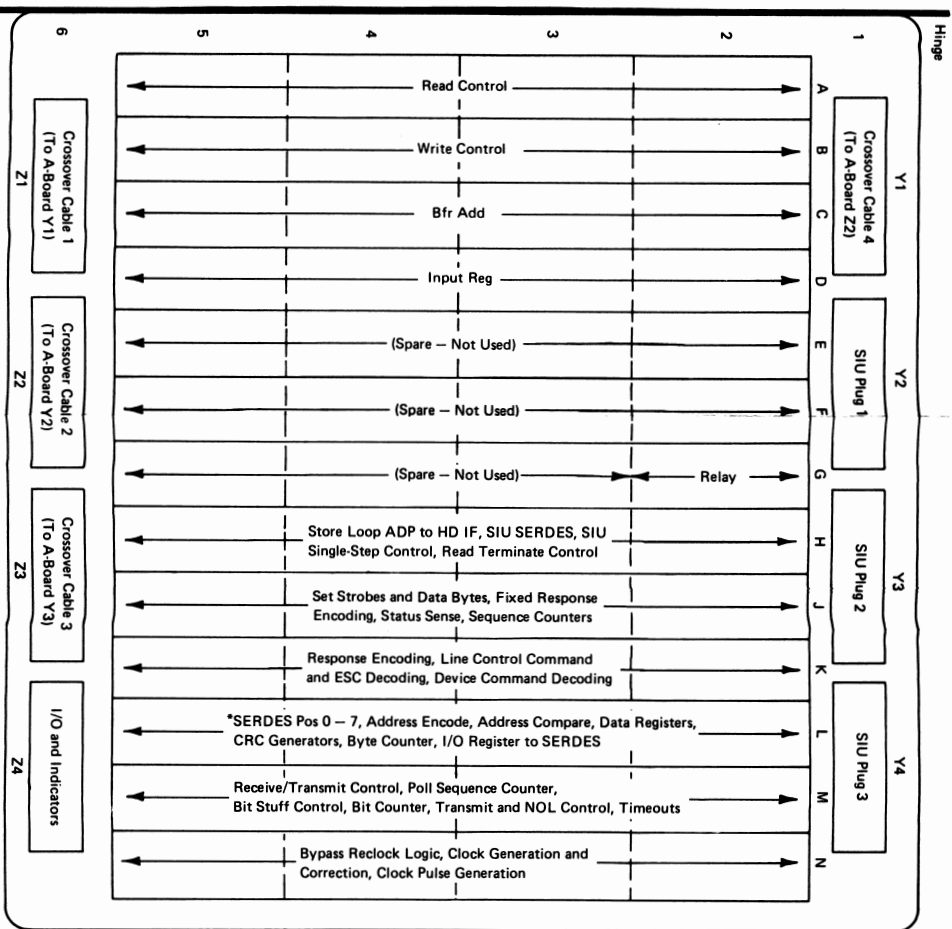

Figure 4-8. 3275 Model 3 A-Gate Card Layout by Function



Legend:

\*Card requires jumpering for address.

Figure 4-9. 3275 Model 3 B-Gate Card Layout by Function

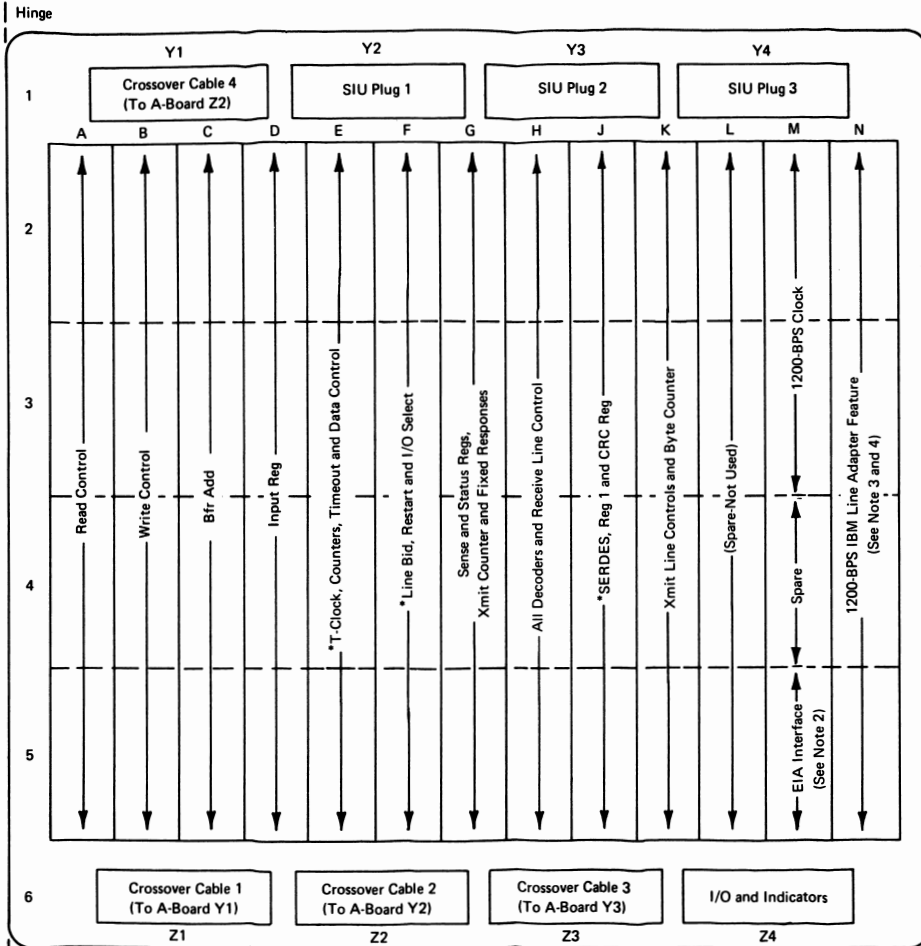

Notes:

1. ASCII Feature Cards
  - \*E2 – ASCII T-Clock and Timeout.
  - G2 – ASCII Fixed Inputs, Status Reg and Xmit Ct.
  - H2 – ASCII Decoder, LRC Reg and LRC SERDES.
  - J2 – SERDES and ASCII/EBCDIC Code Converters.
  - D2 – ASCII Input Reg.
2. EIA Interface Card only: B-M5 (One card wide)
3. 1200 bps Line Adapter feature without Auto Answer: B-N2 and B-N4 (Two 2 wide cards)
4. 1200 bps Line Adapter feature with Auto Answer: B-N2 (One 4 wide card)

Figure 4-10. 3275 B-Gate Card Layout by Function (Dial)

Legend  
\* = Cards with jumpers

## 3275 MODEL 1 AND 2 CARD SUBSTITUTION LIST

The following is a card substitution list approved only for use in the United States on 3275 Display Stations.

### Key

- FO = Factory Only
- NA = Not Available
- CC = Needs Companion Card
- BW = Needs Board Wiring
- MR = Minimum Rework - Functionally equivalent to the PN listed immediately below it.

The Underlined PN is the latest level card.

Cards may be substituted up or down as long as board wiring (BW) is not required.

### Basic Unit

#### "A" Gate - Video Control

Loc	PN	Key	ECA/EC	Function/Comments
A1A2----	8522001		005/718557	Kybd Controls 2
	8523616		017/718965	
	8523633		FO/739273	
	8527296			
	8528262		NA/744145	
	8564132		/746051	Opt/Kybd Adapt
	<u>8564143</u>		/747013	
A1B2----	8522852		005/718557	Kybd Controls 1
	<u>8524282</u>		030/739069	
A1C2----	8521992		005/718557	I/O Gating & Parity
	<u>8523648</u>		031/739068	
A1D2----	<u>8521862</u>		005/718557	480 Storage & Gate
A1D2----	<u>8521863</u>		005/718557	960 Storage & Gate
A1E2----	8522140		005/718557	Head to CU Adapter 2
	8522847		013/718554	
	8523638	BW	027/738651	
	<u>8526058</u>		051/740860	
A1F2----	<u>8521863</u>		005/718557	960 Storage & Gate
A1G2----	8522121		005/718557	Head to CU Adapter 1
	<u>8527982</u>		065/742876	
A1H2----	8522825		005/718557	Clock and Step Control
	8523617		021/718972	
	8523649		003/739073	
	<u>8524604</u>		FO/740386	
A1J2----	<u>8522836</u>		005/718557	Display Control
A1K2----	8520576		005/718557	Model 1 Standard
	<u>8524302</u>		039/739545	
A1K2----	8520577		005/718557	Model 2 Standard
	<u>8524289</u>		039/739545	

"B" Gate - Leased Line

Loc	PN	Key	ECA/EC	Function/Comments
B1A2----	8522183		005/718557	Read Control
	8524322		036/739544	
	8524597	MR	044/740032	
	8524594		044/740032	
	<u>8563023</u>		NA/745463	
B1B2----	<u>8521717</u>		005/718557	Write Control
B1C2----	<u>8522105</u>		FO/718552	Buffer Address
B1D2----	<u>8521732</u>		FO/718552	EBCDIC Input Reg
B1D2----	8521732		005/718557	ASCII Input Reg
	<u>8522846</u>		012/718553	
B1G2----	8521978		005/718557	Init. & Unit Selection
	8528269	MR	NA/744155	
	<u>8528270</u>	BW	NA/744155	
B1H2----	8521712		005/718557	EBCDIC - Status & Sense Regs
	8522868		019/718951	
	8523645		028/739062	
	8526059	BW	048/740862	
	<u>8527916</u>		064/742862	
B1H2----	8521448		005/718557	ASCII-Status & Sense Regs
	8522869		019/718951	
	8523646		028/739062	
	<u>8527977</u>	BW	064/742862	
B1J2----	<u>8521967</u>		005/718557	EBCDIC - T-Clock
B1J2----	<u>8521968</u>		005/718557	ASCII - T-Clock
B1K2----	8521865		005/718557	EBCDIC - All Decoders
	8526054	MR	FO/740027	
	8527295		NA/741254	
	8528256		NA/743331	
	<u>8565001</u>		NA/747501	
B1K2----	8522005		005/718557	ASCII - All Decoders
	8528257		NA/743331	
	<u>8565000</u>		NA/747501	
B1L2----	<u>8521864</u>		005/718557	EBCDIC - Serdes
B1L2----	8521447		005/718557	ASCII - Serdes
	<u>8522849</u>		012/718553	
B1M2----	8521516		005/718557	EIA Driver
	8523640		FO/738654	
	8523658		FO/739558	
	8526047	MR	047/740037	
	8523662	BW	047/740037	
	<u>8527981</u>		NA/742874	

"B" Gate - Dial

Loc	PN	Key	ECA/EC	Function/Comments
B1A2----	8522183 8524322 8524597 8524594 <u>8563023</u>	MR	005/718557 036/739544 044/740032 044/740032 NA/745463	Read Control
B1B2----	<u>8521717</u>		005/718557	Write Control
B1C2----	<u>8522105</u>		FO/718552	Buffer Address
B1D2----	<u>8521732</u>		FO/718552	EBCDIC Input Reg
B1D2----	8521732 <u>8522846</u>		005/718557 012/718553	ASCII Input Reg
B1E2----	8522135 <u>8524286</u>	CC	006/718549 029/739541	EBCDIC T-Clock
B1E2----	8522145 8523267 <u>8524287</u>	CC	006/718549 FO/718966 029/739541	ASCII T-Clock
B1F2----	8522859 8524317 8524585 8524586 <u>8563030</u>	MR	006/718549 FO/739276 040/740021 040/740021 074/745475	Line Bid
B1G2----	<u>8521846</u>		006/718549	EBCDIC-Status & Sense Regs
B1G2----	<u>8522865</u>		006/718549	ASCII-Status & Sense Regs
B1H2----	<u>8522864</u>		006/718549	EBCDIC - All Decoders
B1H2----	<u>8522866</u>		006/718549	ASCII - All Decoders
B1J2----	<u>8522842</u>		006/718549	EBCDIC - Serdes
B1J2----	<u>8522863</u>		006/718549	ASCII - Serdes
B1K2----	8523249 8523260 <u>8524285</u>	CC	006/718549 FO/718963 029/739541	Xmit Line Controls
B1M2----	<u>8521824</u>			
B1M5----	<u>8521719</u>		006/718549	EIA Interface

"B" Gate - Model 3

Loc	PN	Key	ECA/EC	Function/Comments
B1G2----	<u>5863960</u>			Loop Bypass Relay
B1H2----	8525999 <u>8528254</u>		NA/742860	SIU Serdes and Control Control Unit to Interface Control
B1J2----	8526027 <u>8527298</u>		053/740390 058/741763	Fixed Response Encode Status Reg, Sequence
B1K2----	8526028 8527915 <u>8528258</u>	MR	053/740390 NA/742860	Line Control and CMD Decodes Fixed Resp Control
B1L2----	<u>8526004</u>			Serdes Address Compare, DVC Address Encode, CRC Reg, Byte Counter
B1M2----	8526000 8527310 <u>8527978</u>	BW	061/742200 063/742870	Bit Stuff, Destuff, Rcv Xmit Control, Poll Seq Control, Bit Counter
B1N2----	8524641 <u>8526965</u>		057/741243	Bypass Reclocking, Clock Gen and Correction, Clock Pulse Gen, Loop Drivers, and Receivers

## Other Features and RPOs

Loc	PN	Key	ECA/EC "A" Gate	Function/Comments
A1A2----	<u>8522854</u> <u>8523625</u>		005/718557 023/718978	AB3953/2260 compatibility
A1A2----	<u>8526046</u>		FO/740388	ME0731/2260 new line
A1B2----	<u>8523639</u>		FO/718949	WD5095/tab to colon
A1B2----	<u>8522853</u>		005/718557	AB3953/2260 compatibility
A1B2----	<u>8522853</u>		FO/740388	ME0731/2260 new line
A1B2----	<u>8523656</u> <u>8524602</u>		FO/739555 REA69547	WD3140/print key
A1C2----	<u>8522872</u>		FO/718949	WD5095/tab to colon
A1K2----	<u>8521708</u>		005/718557	8K0366/Dual Case
A1L2----	<u>8522115</u> <u>8524324</u> <u>8526677</u> <u>8526678</u>	BW,MR	005/718557 035/739551 NA/740873 NA/740873	Dedicated printer
A1L2----	<u>8523657</u>		FO/739555	WD3140/print key
A1L4----	<u>8521437</u> <u>8524314</u>		005/718557 039/739545	8K0366/Mod 1 Dual Case
A1L4----	<u>8521436</u> <u>8524301</u>			8K03661 Mod 2 Dual Case
A1M2----	<u>8521505</u>		005/718557	Selector Pen
A1N2----	<u>8522108</u> <u>8523257</u>	BW	005/718557 014/718959	Card Reader
A1N2----	<u>8526681</u>		FO/738417 "B" Gate	EE8197/7460-4 Card Reader
B1F2----	<u>8521824</u>		005/718557	1200 bps
B1F2----	<u>8522131</u>		005/718557	Hi-bps
B1M2----	<u>8528261</u>		NA/743338	Mil Specification
B1N2----	<u>5862916</u> <u>5863955</u>		006/718549 FO/741245	Line Adapter w/Auto Answer
B1N2----	<u>8524284</u>		NA/739267	Mil Specification
B1N2----	<u>5862858</u>  <u>5863763</u>		005/718557  FO/738646	Line Adapter w/o Auto Answer (Xmit)
B1N4----	<u>5862859</u>		005/718557	Line Adapter w/o Auto Answer

Note: For 3275 Models 11 and 12 SDLC card part numbers, refer to Section 8 of this handbook.



**3275 Model 1 and 2 EC Cross-Reference**

This chart (Figure 4-11) is to be used to determine the need for any of the optional EC changes and to verify the EC level of any machine. To aid in determination the serial number that implemented each change is listed. This list will be updated periodically. It is recommended that a copy of this service aid be kept in 3270 card caddies.

ECA	EC	REA	Pre-Req ECA	Concur or Comp	Opt/Mand	Feature Affected	Break In Serial #	Cards Affected		Board Wiring Involved	Card Loc	Card Type	Description
								Old P/N	New P/N				
001	717484			None	Mand	Base	80066	N/A	N/A	Yes			Factory installed on all machines.
002	717942	06-63201 06-63202 06-63203	ECA 001		Mand	Base	80269			Yes			This change was shipped to all machines.
003	Cancelled		None										EC was cancelled after ECA was assigned.
004	717952		None		Mand		80617						Field B/Ms were composited into EC 718557.
005	718557	63206	ECA 002	None	Mand	Base — Dual Case Katakana	81274	8521853 8522000 8522014 8522128 8522120	8522153 8522852 8522836 8522001 8522833	Yes	B1A2 A1B2 A1J2 A1A2 A1L2	9080 9069 9067 9072 2214	This change corrects: 1. Backspace blink. 2. Keyboard compatibility. 3. Data entry functional problem. 4. Katakana functional problem.
006	718549		None	None	Mand	Dial	81274	N/A	N/A				Factory installed on all Dial machines. No field B/Ms required.
007	718396		None	None	Mand	Base	N/A						This change provides an Arc suppression network to protect analog cards P/N 2565236. This change is not necessary for analog card P/N 2565080.
008	718348		None	None	Mand	Keyboard	80699	N/A	N/A	None			Keyboard audible feedback asm failures caused by residual magnetism, type A keyboard only.
009	718342		None	None	Opt	Keyboard	81029	N/A	N/A	None			Redesigned clicker card for audible feedback asm, type A keyboard only.
010	718868		None	None	Opt	Base	80972	N/A	N/A	None			Redesigned low-voltage power supply. Released new ferro-xmer to replace noisy (loud hum) 60 Hz ferros.
011	718869		None	None	Opt	Base	N/A	N/A	N/A				Eliminates high-frequency noise caused by yoke and analog card.
012	718553		ECA 005	None	Mand	ASCII	81479	8521447 8521732	8522849 8522846	None	B1L2 B1D2	9110 X463	Corrects ASCII translate problems. Symptoms: 1. 3275 will not respond to selection address 4C. 2. Xlates an EBCDIC 6A to 5C instead of 7C.

Figure 4-11 (Part 1 of 7). 3275 Model 1 and 2 EC Cross-Reference Chart

ECA	EC	REA	Pre-Req ECA	Concur or Comp	Opt/Mand	Feature Affected	Break In Serial #	Cards Affected		Board Wiring Involved	Card Loc	Card Type	Description
								Old P/N	New P/N				
013	718554		ECA 005	None	Opt	Base	81535	8522140	8522847	None	A1E2	9030	Prevents honoring another attn key while selected for a read or write operation.
014	718959		ECA 017	None	Mand	Magnetic Card Reader	82847	8522108	8523257	Yes	A1N2	2229	Corrects MDT bit placement in I/O operations and corrects timing error to prevent attribute being entered at data character. Card reader feature only.
015	718335		None	None	Mand	All	81809	N/A	N/A	N/A			Provided new IR Functional Unit Code Guide form #S229-7018-1.
016	718973												World Trade use only.
017	718965		None	None	Opt	Base	82847	8522001	8523616	Yes	A1A2	9072	1. Corrects double characters on screen caused by numeric field speed shifting. 2. Corrects multiple cursors with card reader feature.
018	738620		None	None	Mand	Base	82104	N/A	N/A	None			Provides new linecord to prevent intermittent loss of input power.
019	718951		ECA 005	None	Opt	Base	81587	EBC1D1C 8521712	8522868	None	B1H2	9041	Field B/Ms have been cancelled. EC 740862 will pick up this EC.
								ASC11 8521448	8522869	None	B1H2	9111	Field B/Ms have been cancelled. EC 739062 will pick up this EC.
020	738628		None	None	Opt	Base	82104	N/A	N/A	N/A			Provides an improved on/off switch spring to ensure a more positive action.
021 Cancelled See ECA 033	718972		ECA 005	None	Opt	Model 1 only	83086	8522825 or 8521981	8523617	None	A1H2	9071	Corrects non-display attribute in last position from causing hi-intensity display in position 0. Cancelled See ECA 033.
022	739021		None	None	Mand	Base	82172	N/A	N/A				+5 Volt power supply change provides additional current capacity for 5 Volt return circuit. Adds a jumper wire in place of land pattern on power supply PC board.
023	718978		ECA 005	None	Opt	2260 Compat. and Card Reader	82830	8522854	8523625	None	A1A2	X457	Provides new card to allow 2260 compatibility to operate with card reader feature.

Figure 4-11 (Part 2 of 7). 3275 Model 1 and 2 EC Cross-Reference Chart

ECA	EC	REA	Pre-Req ECA	Concur or Comp	Opt/ Mand	Feature Affected	Break In Serial #	Cards Affected		Board Wiring Involved	Card Loc	Card Type	Description
								Old P/N	New P/N				
024	738622												World Trade use only.
025	718971		None	None	Mand	Tab to Colon RPQ	82130	8522871 or 8523636	8523639	None	A1B2	X927	Dup key causes hang condition when buffer is unformatted. Tab to colon RPQ only.
026	738639		None	None	Mand	Base	83472	N/A	N/A	None			Provides amp connector stiffener clip to ensure a more positive connection of amp connectors to PC boards and analog card. <i>Note:</i> Amp connectors that have experienced burning prior to this change may continue to arc and should be replaced.
027	738651		ECA 005	None	Opt	Model 1 only	83414	8522847	8523638	Yes	A1E2	9030	Corrects data transfer errors when attri- butes are located in odd-decimal positions only. Affects Model 1 only.
028	739062		ECA 005	None	Opt	Base	83681	EBCDIC 8522868	EBCDIC 8523645	None	B1H2	9041	Field B/Ms have been cancelled. EC 740862 will pick up this EC.
								ASCII 8522869	ASCII 8523646	None	B1H2	9111	
029	739541		ECA 006	None	Mand	Dial	83801	EBCDIC 8522135	EBCDIC 8524286	None	B1E2	4716	Corrects timeouts on read operations of greater than 256 bytes. Affects Dial machines only.
								ASCII 8523267	ASCII 8524287	None	B1E2	4723	
030	739069		ECA 005	None	Opt	Base	84077	8522852	8524282	None	A1B2	9069	Multiple cursors appear on screen when BACKTAB operation is interrupted by backspace, period, comma and # or S.
031	739068		ECA 005	None	Opt	Base	80429	8521992	8523648	None	A1C2	9066	Electrical noise causes partial power on reset. Symptom: Screen blanks — includ- ing cursor momentarily then cursor reappears.
032	738367	06-69181	ECA 002	None	Mand	Magnetic Card Reader	84218	N/A	N/A	Yes			This change installs a resistor asm to correct intermittent card reader failures.

Figure 4-11 (Part 3 of 7). 3275 Model 1 and 2 EC Cross-Reference Chart

ECA	EC	REA	Pre-Req ECA	Concur or Comp	Opt/ Mand	Feature Affected	Break In Serial #	Cards Affected		Board Wiring Involved	Card Loc	Card Type	Description
								Old P/N	New P/N				
033	739073		ECA 005	None	Opt	Base	83472	8522825	8523649	None	A1H2	9071	Corrects a hang condition in the dot counter logic. Symptom: Screen blanks. All information is lost including cursor.
034 Cancelled See ECA 040	739276		ECA 005	None	Opt	Dial		8522859	8524317	None	B1F2	4714	Field B/Ms were cancelled. EC is picked up by EC 740021. See ECA 040
035	739551	06-63212	ECA 005	None	Mand	Print Adapter	84429	8522115	8524324	None	A1L2	9092	Corrects an incorrect decode of a character 9. It interprets it as an end-of-message and causes the printer to stop printing before the end-of-line.
036	739544		ECA 005	None	Opt	Base/With Light Pen Feature	84429	8522153	8524322	None	B1A2	9080	Corrects sending an incorrect character when performing a reread of a block of data ending in ETB. The AID or SBA or First Data Character may be clobbered on the reread operation.
037	739550A		ECA 005	None	Mand	Base/Without Line Pen Feature	83801	N/A	N/A	Yes			Same as ECA 036, for machines without light pen feature. This change is not needed if 739544 is installed.
038	738654			None									This is a factory-only change. Field B/Ms will be composited into EC 740037.
039	739545		ECA 005	None	Opt	Base/ Dual Case	84375	Model 1 Standard 8520576	Model 1 Standard 8524302	None	A1K2	9058	Corrects a short cursor problem.  Symptom: Short or blinking cursor displayed on screen.
								Model 2 Standard 8520577	Model 2 Standard 8524289	None	A1K2	9070	
								Model 1 Dual Case 8521437	Model 1 Dual Case 8524314	None	A1L4	2231	
								Model 2 Dual Case 8521436	Model 2 Dual Case 8524301	None	A1L4	2227	

Figure 4-11 (Part 4 of 7). 3275 Model 1 and 2 EC Cross-Reference Chart

ECA	EC	REA	Pre-Req ECA	Concur or Comp	Opt/ Mand	Feature Affected	Break In Serial #	Cards Affected		Board Wiring Involved	Card Loc	Card Type	Description
								Old P/N	New P/N				
040	740021	06-92452	ECA 005	None	Opt	Dial	84375	8524317	8524586	None	B1F2	4714	<ol style="list-style-type: none"> <li>1. Corrects disconnect message being cut short because the machine was disconnecting at the same time it was sending the END PAD (FF).</li> <li>2. Unable to hang up the phone if a system ready condition was not obtained on Dial machines with the line adapter feature and auto answer. This EC picks up EC 739276 ECA 034.</li> </ol>
041	740659		None	None	Opt	Keyboard Type B Only	N/A	N/A	N/A	None			To reduce keyboard contamination problems by installing new keyboard (less covers). See ECA 041 for details to determine applicable Field B/M.
042	740096	None	None	Mand	Opt	Keyboard Type B Only	N/A	N/A	N/A	None			Eliminates possible keyboard errors due to contamination, and provides ac/dc ground separation to eliminate difficulty to define ground loop problems.
043	740098	None	None	None	Opt	Keyboard Type B Only	N/A	N/A	N/A	None			This is a notice-only change to allow removal of Type B keyboards which have superslick modules. Superslick modules are white and may be identified by looking under keyboard at lip of module. See ECA 043 for further details.

Figure 4-11 (Part 5 of 7). 3275 Model 1 and 2 EC Cross-Reference Chart

ECA	EC	REA	Pre- Req ECA	Concur or Comp	Opt/ Mand	Feature Affected	Break In Serial #	Cards Affected		Board Wiring Involved	Card Loc	Card Type	Description
								Old P/N	New P/N				
044	740032	06-63218	ECA 005	None	Opt	Base	REA 63218 84460 EC 740032 85332	8524322	8524597 MR 8524594 EM	None	B1A2	9080	When executing a read modified, a reread of the last block of multiple data blocks is generated because of a BCC error detected at the TCU. The retransmitted data is incomplete.
045	739991		ECA 005	None	Opt	Base	85210	N/A	N/A				Provides some protection from damage caused by an electrical storm (lightning).
046 Cancelled	740027	06-81048	ECA 005	None		Base		8521865	8526154 MR	None	B1K2	9042	Field B/Ms have been cancelled - EC741254 will release the field B/Ms at a later date.
047	740037	06-81047	ECA 005	None	Opt	Base	84997	8523658	8526047 MR 8523662 EM	None for REA 06-81047 Yes for EC 740037	B1M2	9045	Corrects bit shifting problems due to crosstalk.  Symptoms: Line drop, CU dropped from pollinglist. Transmission checks. Status lights. Timeouts.
048	740862	06-81049	ECA 005 ECA 047	None	Opt	Base	86026	8523645	8526059	Yes	B1H2	9041	Corrects improper ACK response. It will only step the ACK counter upon receipt of a good BCC. Symptoms: Line drop. Timeouts. Wrong ACK response. ENG - ACK loops.
049	740874		ECA 005	None	Opt	Leased Line with Line Adapter	N/A	N/A	N/A				Provides jumpering instruction for decreasing clear-to-send delay for 4-wire machines with the line adapter feature.

Figure 4-11 (Part 6 of 7). 3275 Model 1 and 2 EC Cross-Reference Chart

ECA	EC	REA	Pre-Req ECA	Concur or Comp	Opt/ Mand	Feature Affected	Break In Serial #	Cards Affected		Board Wiring Involved	Card Loc	Card Type	Description
								Old P/N	New P/N				
050 Mod 1, 2, and 3	741722		None	None	Mand	Base	87744 - Mod 1 & 2  89044 - Mod 3	None	None				Provides additional secondary circuit protection. Adds fusing for +5V and +34V.
051 Mod 1, 2	740860	06-63214	ECA 005	None	Opt	Base	87178	8523638	8526058	None	A1E2	9030	This change allows a RVI control message to reset the device check latch. The device check was not being reset and would cause certain error recovery procedures to hang the system.
052 Mod 1, 2, and 3	741726		None	None	Mand	Base	87864 - Mod 1 & 2	None	None	None			Provides a safety cover to prevent power cord from contacting the hinge screw.
053 Mod 3 Only	740390		None	None	Mand	Mod 3 2400 Baud	89039	8526001 8526003	8526027 8526028	None	B1J2 B1K2	Y786 Y787	Provides a proper status and sense return on status request and reset commands.
054	942768												World Trade use only.
055 Mod 1, 2	741254		ECA 005	None	Opt	Base	88391	8521865	8527295	None	B1K2	9042	Corrects timeout after sending data and receiving wrong ACK. This EC replaces EC 740027.
056	740873	0681051	ECA 005	None	Opt	With Print Adapter	88142	8524324	8526677 8526678	Yes	A1L2	9092	Corrects invalid status message. Problem arises when IR or EC is brought up during a poll. Any part or all of the status may be lost or altered.
057 Mod 3	741243			None	Opt	Mod 3 Only	A9079	8524641	8526965	None	B1N2	Y782	1. Provides ac overvoltage protection for loop drivers.  2. Prevents interruption to the loop caused by pick of loop bypass relay when power is turned on.

Figure 4-11 (Part 7 of 7). 3275 Model 1 and 2 EC Cross-Reference Chart

**3275 SERVICE AIDS**

**Line, Modem Scoping Procedure**

Use the following procedure to verify line or modem problems:

1. Power off the 3275 and connect the SIU for offline use.
2. Power on 3275.
3. Perform an initial selection routine including the ACK 0 RESPONSE.
4. Perform a Read Modified command. When the text message response to the Read Modified command is complete, reply with a wrong ACK (ACK 0).

```

32 32 10 70 FF (EBCDIC)
16 16 10 P30 P7E (ASCII)
    
```

5. The 3275 will respond to the wrong ACK with an enquiry sequence.

```

55 32 32 2D (EBCDIC) 2400, 4800, 7200 bps rates
55 16 16 P5 (ASCII) 2400, 4800, 7200 bps rates
    
```

*Note:* (1200-bps rate will have 3 start pads (55) preceding message instead of 1)

Verify in SERDES that the RESPONSE is correct.

6. Place SIU on/line off/line switch to on/line. The 3275 will now send the enquiry sequence down line to the TCU at the system site every 3 seconds if the timeout override switch on the SIU is placed in the NORMAL position.
7. Scoping can now be performed at the TCU (Receive data) for the correct enquiry sequence from the 3275.
8. For continuous uninterrupted transmission, jumper 01B-A1M2J13 to ground (D08).

EBCDIC Pattern every 3 sec from 3275 to TCU

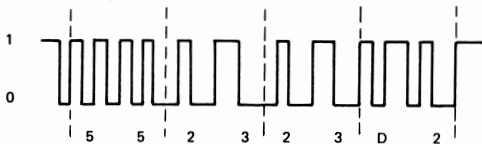

ASCII pattern every 3 sec from 3275 to TCU

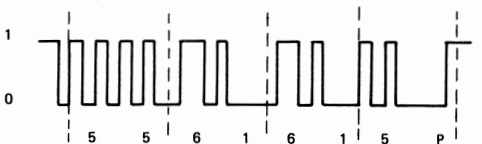

- Notes:*
1. Data bytes appear to be reversed. This is normal because of the shifting of the SERDES shift register in the 3275.

2. SCOPE Timings
  - 1200-bps Rate - 5 ms/div
  - 2000- -
  - 2400-bps Rate - 2 ms/div
  - 4800-bps Rate - 1 ms/div
  - 7200-bps Rate - .5 ms/div

### Probe points for Monitoring PT2 or B-TDAT

The following pins can be used for 3275 Models 1 and 2 with undercover modem for attaching a PT2 or buffered TDAT for monitoring purposes (all probes are on the B-gate):

SCR	+ SCR or SCT 1200/900 BPS	M2B11
CD	+ CARRIER DETECT EIA	N4D02
RD	- RECEIVE DATA	N4D13
SCT	+ SCT or SCR 1200/900 BPS	F2D12
CS	+ CLEAR TO SEND EIA	M2B09
RS	+ REQUEST TO SEND EIA	N2D04
SD	- SEND DATA	N2J11

Note that Receive Data and Send Data are minus levels. Minus levels on these two signals are active levels and do not have to be inverted on the PT2 or buffered TDAT.

## Version Level Feature Identification

The 3275 uses ALD version levels to identify models and character format in ALD Vol. 1 (A gate). In Vol. 2, ALD version levels identify the type of remote interface and features installed.

The following is a cross-reference list of ALD version numbers to model and/or features. Also included are the board PNs for each version.

### Vol-1 (A gate)

Version	Volume Description	Board PN	Notes
000	Standard Model 2	2625226	2
005	Katakana Model 2	2625236	2
007	Dual Case Model 2	2625236	2
002	Standard Model 1	2625226	2
A25	Katakana Model 1	2625236	2
A27	Dual Case Model 1	2625236	2

### Vol-2 (B gate)

Version	Volume Description	Board PN	Notes
000	Leased EBCDIC w/wo Lo-bps	2625228	3
004	Leased EBCDIC Hi-bps	2625232	3
003	Leased ASCII w/wo Lo-bps	2625230	3
A03	Leased ASCII Hi-bps	2625234	3
006	Leased EBCDIC Katakana w/wo Lo-bps	2625238	3
010	Leased EBCDIC UCM	2625244	1,3
B10	Leased ASCII UCM	2625248	1,3
C10	Leased Katakana UCM	2625246	1,3
012	9600 bps RPQ 8K0498	1740294	-
030	Dial EBCDIC UCM Auto Answer	2625752	3
B30	Dial EBCDIC UCM	2625752	1,3
C30	Dial EBCDIC External	2625752	3
040	Dial ASCII UCM/Auto Answer	1829958	3
B40	Dial ASCII UCM	1829958	1
C40	Dial ASCII External	1829958	3
B36	Dial Katakana Auto Answer	2625754	3
C36	Dial Katakana UCM	2625754	1
D36	Dial Katakana External	2625754	3
061	Leased Katakana Hi-bps	1657192	3
050	Model 3 - 2400 bps	1833026	-
051	Model 3 - 9600 bps	1657196	-
052	Model 3 - 2400 Katakana	1657194	-
053	Model 3 - 9600 Katakana	1653854	-

#### Notes:

- 1 UCM = Under Cover Modem (line adapter feature)
- 2 Refer to socket listing ALD A1115 for location and PNs of feature cards such as selector pen, card reader, and dedicated printer.

Refer to ZZIXX pages for location and PNs of RPQs such as 2260 compatibility, Dual Case, print key, and tab to colon.

- 3 Refer to socket listing ALD A2115 for location and PNs of RIF feature cards such as Lo-bps, Hi-bps, Line Adapter (UCM), and Dial.

## 3275 Line Adapter Installation

1. Field installation of line adapter has attachment of dc return wire missing in installation instructions.

Field installation of the line adapter feature requires an additional +12V supply to be added to the base machine.

The dc return line may not be attached on some machines, resulting in 36V being present on the N2 and N4 cards. Check that wire # 8 in cable PN 2565246 is attached to pin 10A on the voltage distribution board. This wire may be taped back into the cable.

2. Base machine wiring verification. The above-mentioned wire is not necessary for proper operation w/o line adapter feature. However, this wire should be attached on all machines. Check for this wire on the next service call. Use service code 34 for base machine wiring verification.

## Incorrect Characters or Quote Marks on 3275 Screen With Status Light

1. Incorrect or garbled characters on the 3275 accompanied by a status light is an indication of a transmission check (status/sense C140). Transmission check (TC) is caused by a BCC error detected by the 3275. BCC checking is the method used to insure the integrity of the data *received* by the 3275. TC is usually caused by line disturbances, modem or TCU errors. It may also be caused by the EIA driver card at 01BA1M2. If replacing the EIA driver card does not fix your problem, contact central site for status/sense information. Error recovery should be to reconstruct the entire device buffer and retry the failing chain of commands. A minimum of six retries should be attempted before the error is considered non-recoverable. See 3270 Component Description manual (GA27-2749) Chart 20 for further information. *Note:* When the 3275 detects a BCC error, it will set TC and responds with EOT. 3271 responds with NAK.
2. Quotation marks on the screen is the result of the 3275 not receiving/recognizing an ETX. As a result, when the line goes to a mark level, the 3275 decodes this as all bits (HEX FF). If the 3275 was unable to decode the ETX, it then decodes the FF characters and places quotes on the screen. Quotation marks will also be displayed with intermittent loss of carrier.

## Field Installation of 4800/7200 Bps Feature

Field installation of the 4800/7200 bps Feature (feature code 7821) has an EC incompatibility problem.

If 01B board is at EC 740037 (ECA 047) or EC740862 (EC 048), the card at 01B-A1H2 must be updated as follows:

Board Level	Card PN at 01B-A1H2
EC 740037	8522868 or 8523645
EC 740862	8526059

*Note:* PN 8521712 *cannot* be used with the 4800/7200 bps Feature when the board is at EC 740037 or 740862.

Use Service Code 31 for any cards used.

## +5V Fuse

Blowing the +5V fuse will cause "Request-to-Send" to come up solid on the EIA interface.

**TEXT:** With EC 741722 installed, blowing of the +5V fuse will cause "Request-to-Send" to come up solid on the EIA interface. In most applications, this could cause an entire line to hang or be removed from the polling list. Instruct the operator that when the symptoms listed below are observed, the control unit should be powered down and call for service.

**SYMPTOMS:** 3275: No cursor, all lights are Off.

EC 742874 resolves this problem.

EIA Line Name	EIA Pin No.	3275 Leased Pin No.
Protective Ground	1	"Pigtail to frame ground from cable connector
Transmit Data	2	01B-M2D02
Receive Data	3	01B-M2M10
Request to Send	4	01B-M2B02
Clear to Send	5	01B-M2B09
Data Set Ready	6	Only used on Dial Feature
Signal Ground	7	01B-M2D08
Carrier Detect	8	01B-M2U04
Serial Clock Transmit	15	01B-M2S08
Serial Clock Receive	17	01B-M2M12
Data Terminal Ready	20	01B-M2B13
Ring Indicator	22	Only used on Dial Feature

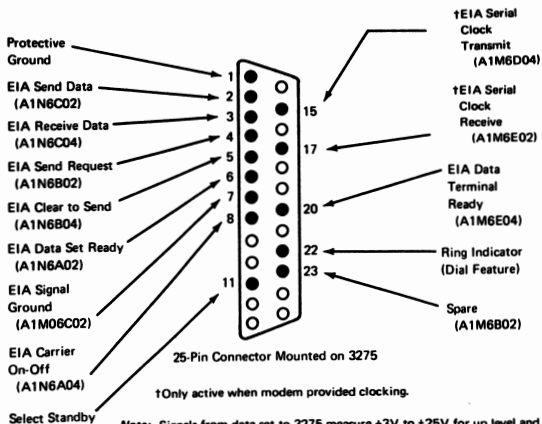

**Note:** Signals from data set to 3275 measure +3V to +25V for up level and -3V to -25V for down level. Signals to data set for 3275 measure +3V to +8V for up level and -3V to -12V for down level. Protective ground pin 1 does not pick up ground from 3270. Ground is the cable shield and is clamped to the 3270.

**CAUTION:** When measuring voltages on the IO Connector, use an oscilloscope. Do not use the General Logic Probe or the standard probe.

## Section 5. 3277 Display Station

### Contents

<b>3277 Symptom Fix List</b> . . . . .	5-3
Display Malfunctions . . . . .	5-3
Keyboard Malfunctions . . . . .	5-5
Power Malfunction . . . . .	5-7
CPU Error Indicators . . . . .	5-7
<b>3277 Card Substitution List</b> . . . . .	5-11
Basic Unit . . . . .	5-11
Feature or RPQ Units . . . . .	5-12
<b>3277 Model 1 and 2 EC Cross-Reference</b> . . . . .	5-15
<b>3277 Service Aids</b> . . . . .	5-21
Analog Cards 2565236 and 2565080 . . . . .	5-21
Multiple Characters . . . . .	5-22
Interchangeable Data Entry and Typewriter Keyboards . . . . .	5-22
Defective Line Cords . . . . .	5-23
Contamination Problems on Type B Keyboards . . . . .	5-23
Air Flow Restrictions . . . . .	5-24
New PC Board Part No. for Type B Keyboards . . . . .	5-24
Part No. Change . . . . .	5-24
Screen Blanking . . . . .	5-24
Installation of PN 2577718 in Wrong Location . . . . .	5-24
Lightning Protection . . . . .	5-25
PC Board PNs for RPQ Keyboards . . . . .	5-25
Feature MES Keyboard PNs and Replacement Assembly PNs . . . . .	5-25
Type A Keyboard PNs for 3277 . . . . .	5-26
3277 Ship Group . . . . .	5-26
3277 Board PN List . . . . .	5-27
High-Frequency Noise . . . . .	5-28
Selector Pen Replacement of Tip . . . . .	5-28

### Figures

Figure 5-1. 3277 Data Flow . . . . .	5-9
Figure 5-2. 3277 A-Gate Card Layout by Function . . . . .	5-10
Figure 5-3. 3277 Model 1 and 2 EC Cross-Reference Chart (6 parts) . . . . .	5-15



## Section 5. 3277 Display Station

Figures 5-1 and 5-2 give the locations for the 3277 Display Station

### 3277 SYMPTOM FIX LIST

The following Symptom Fix List should be used to supplement the existing procedures in the MLTG.

Symptom	Fix
<b>Display Malfunctions</b>	
<b>NO DISPLAY:</b>	
No visible light or glow on CRT after POR.	Change card E2.
No visible light or glow on CRT.	Change cards: E2, G2, H2, J2. Resolder -12V regulator card socket connections on LVPS board. Replace: LVPS, HVPS, analog card, or voltage distribution board connectors, arc-suppression neon arc-suppression board, +5V bus bar on logic board.
<b>INTERMITTENT DISPLAY:</b>	
Blanks momentarily; data lost and cursor repositioned at 00.	Replace cards E2, C2. Replace: voltage distribution board, arc-suppression neon or board.
Blanks when display station is polled; cursor move key(s) causes cursor to appear.	Replace card G2.
Cursor (only) flashes on and off.	Replace CRT.
Disappears and reappears (similar to POR).	Replace card C2. Tighten LVPS cap screws. Replace: HVPS connector clips or HVPS, LVPS.
Flashing display.	Replace card E2.
Flashing dots on display.	Replace LVPS (Damage may have resulted from burned PS connector. Check that ECA 022 or 023 is installed.)
Flashing field in formatted display.	Change card K2.
Arcing display or snapping noise.	Replace HVPS, CRT.
<b>INTENSITY AND FOCUS:</b>	
Low intensity display, or dim cursor.	Replace analog card. Check for loose connections at arc-suppression board.
Low intensity display with horizontal line at top of display.	Replace CRT.
High intensity display when it should not occur.	Replace card F2.
High intensity attribute displays as character H. INPUT INHIBITED lighted.	Replace cards D2, F2.
Normal intensity fields do not display.	Replace card F2.
Intensity varies when display station is idle.	Check for proper ac grounding.
Intensity (brightness/contrast) not adjustable.	Replace: voltage distribution board, arc-suppression neon or board, analog card.
Glow (only) on CRT.	Check for loose cable connections at 01AA1Z3.

**Symptom****Fix**

Display blinks when intensity (brightness/contrast) control is turned down.

Replace ac line cord.

Flashing occurs when brightness/contrast control is turned up.

Check for loose connection(s) in CRT socket.

Flashing and loss of focus occur when brightness/contrast control is increased.

Replace voltage distribution board, arc-suppression neon or board.

Focus cannot be varied with focus control.

Straighten pin 9 on CRT.

Replace: voltage distribution board, arc-suppression neon or board, LVPS, HVPS, CRT.

Compressed raster on screen.

Replace card K2.

Constant raster.

Replace CRT.

One horizontal line on top of display.

Check analog card connections; replace analog card.

Unstable display.

Check for interference from external electrical fields; for example, electric clocks or the Operator Identification Card Reader is located too close to the display station.

Check and repair, if necessary, defective connectors, ac grounds, fuse terminal board.

Replace cards E2, H2, J2, analog card in 3277; P2 in 3271/3272.

Replace HVPS, LVPS.

**CHARACTERS:**

Vertical row of B's displayed.

Replace card D2.

Vertical row of B or D characters displayed INPUT INHIBITED lights.

Replace card F2.

Characters move on display.

Replace card J2.

INPUT INHIBITED lights

Extra characters displayed.

Replace -12V regulator card.

Screen full of character B.

Replace card K2 or buffer card.

Extra dots in each character row.

Replace card K2.

Incorrect characters displayed.

Check for voltage on coax shield.

Characters displayed in line 1 shrink vertically.

Reverse leads on ac capacitor C1.

Misshaped characters displayed.

Replace analog card.

Partial display of characters.

Replace card J2, analog card.

Same character repeated on display.

Replace cards D2, F2.

Format problems.

Check for proper ac grounding.

Random data display after POR.

INPUT INHIBITED lights.

Replace cards D2, F2, G2.

Symptom	Fix
<b>CURSOR:</b>	
Multiple cursor with intervention required status.	Check that logic and frame grounds are connected.
Multiple cursors appear.	Check for loose connector 01AA1Z3.
Cursor not fully displayed and data missing.	Replace cards H2, J2.
Cursor does not move in an unprotected intensified field.	Replace card G2.
Cursor moves backward and data is compressed at top of display.	Replace analog card.
Cursor moves to position 00 and INPUT INHIBITED indicator comes on.	Check I/O cable connections at 01AA1Z4.
Cursor does not move.	Replace card H2.
Cursor does not clear data off display.	Adjust -12V regulator card.
Cursor disappears with control check status.	Replace card G2.
Cursor does not advance to new line.	Replace card G2.
Power comes up with three blinking cursors in upper left corner of display.	Replace card H2 and -12V regulator card.
Cursor moves left and right across top line on display.	Check for loose connection at 01AA1Z3.
Vertical line of cursors on left side of display.	Replace card F2.
Full line of cursors on screen.	Replace voltage distribution board.
<b>INDICATORS:</b>	
SYSTEM AVAILABLE indicator does not light.	Check for loose coax connection. Replace cards E2, G2, J2.

## Keyboard Malfunctions

### CHARACTER KEYS:

Alpha characters are displayed in numeric field (with keyboard numeric lock feature installed).	Remove jumper between A2B06 and A2D08 if logic board is at EC 717946.
When keying rapidly, alpha characters are displayed in numeric field (with keyboard numeric lock feature installed).	Install ECA 023.
Extra characters displayed when signing on.	Replace card H2.
Extra characters displayed when entering one character.	Reseat P2 at voltage distribution board. Check for bent pin at E2D08.
Cursor is visible but characters cannot be entered.	Replace keyboard.
Cursor disappears after first character is entered.	Replace card A2.
No characters can be entered from keyboard.	Replace card J2.
Characters change after entry.	Check for intermittent open connection on -12V wire to keyboard.

Symptom	Fix
INPUT INHIBITED lights after any key entry.	Check for voltage between frame and signal ground. Voltage should be 0. Replace card F2. Replace logic board (defective coupling capacitor).
Last key entry does not display and INPUT INHIBITED lights. Display blanks after key entry.	Replace enter key module. Resolder connection at CLEAR key on keyboard PC board. Replace card E2.
<b>CURSOR CONTROL KEY FAILURE:</b>	
Backspace (←) key, when pressed: Cursor does not move or data moves to the left of the cursor.	Replace card B2.
INPUT INHIBITED lights or data moves to the right of the cursor and cursor does not move.	Replace card J2.
Data moves to right and down to next line.	Replace card H2.
Screen fills with cursors, B, D or H characters.	Replace card C2.
Jitter in top row of data.	Replace analog card (to minimize jitter).
Backtab (↵) key INPUT INHIBITED lights and two cursors appear when tab key (→) pressed in a protected field.	Replace card B2. Replace cards D2, F2.
<b>OPERATOR FUNCTION KEY FAILURES:</b>	
Buffer "runaway" occurs when INS MODE is pressed.	Check that the current level logic board is installed.
Data shift when INS MODE is pressed.	Replace card A2.
INPUT INHIBITED lights when INS MODE is pressed.	Replace card H2, logic board.
<b>PROGRAM ACCESS KEY FAILURES:</b>	
ENTER key inoperative.	Replace key module.
INPUT INHIBITED lights after ENTER key is pressed.	Replace card H2.
Display blanks when ENTER key is pressed.	Replace analog card.
<b>KEYBOARD ASSEMBLY:</b>	
Keyboard clicker not working.	Check for missing wire from A1A2S12 to .A1C6E02 or wire from Z1B13 to A2S11 instead of Z1B13 to A2S12.
Keyboard clicker runs continuously.	Check that ground bus on logic board is plugged to correct pins. Replace LVPS.

**Symptom****Fix****Power Malfunction**

Repeated HVPS failures.  
Bright spot on center of screen.

Replace CRT.  
Check for missing +5V or -12V; burned pins 8 and 9 of J1 on LVPS board; defective analog card.

Fuse 1 blows.

Replace: arc-suppression board (3277 Model 1), voltage distribution boards (3277 model 2).

Check for reversed connection of wires 12 and 14 on voltage distribution board.

Fuse 2 blows.

Replace ferro-transformer.

Fuse 3 blows.

Check for short on -12V wire to keyboard.

Replace cards D2, E2, F2 or K2.

Replace ferro-transformer.

POR does not occur,  
-12V regular card overheats or fails.  
Random intermittent failures.

Replace card G2.

Replace ferro-transformer.

Replace -12V fuse (fuse filament is vibrating).

**CPU Error Indicators**

Continuous attention interrupt.  
Data checks.

Replace card G2.

Check for defective coax connection at 01AA1E2D08. Shield on BNC connector should have continuity with all D08 pins.

Data checks and/or unit checks with INPUT INHIBITED indicator on.  
Error status on initial selection.

Check for ungrounded ac outlet.

Replace card C2, analog card, keyboard.

Check for LVPS short to frame.

Fails on OLT routine 9C.  
System "hangs" and constant busy status.  
INPUT INHIBITED does not go off.

Check for defective cable connections at control unit.

Replace card H2.

Check for incorrect grounding of ferro transformer to D08 pin.

Check I/O cable connections at A1Z1 analog card.

Device check with line of underscored characters. INPUT INHIBITED indicator lights.

Check for loose connections at A1Z1 connector.

Losing display stations to system.

Replace card E2.

Losing display stations to system.

Replace card G2.

Data flashes on screen.

Losing display station to system after master display station exchange.

Check for two ENTER key clicks. Replace ENTER key module.

Control checks, ripple on display.  
INPUT INHIBITED lights.

Check that connection is made between E2D07 and E2D08.



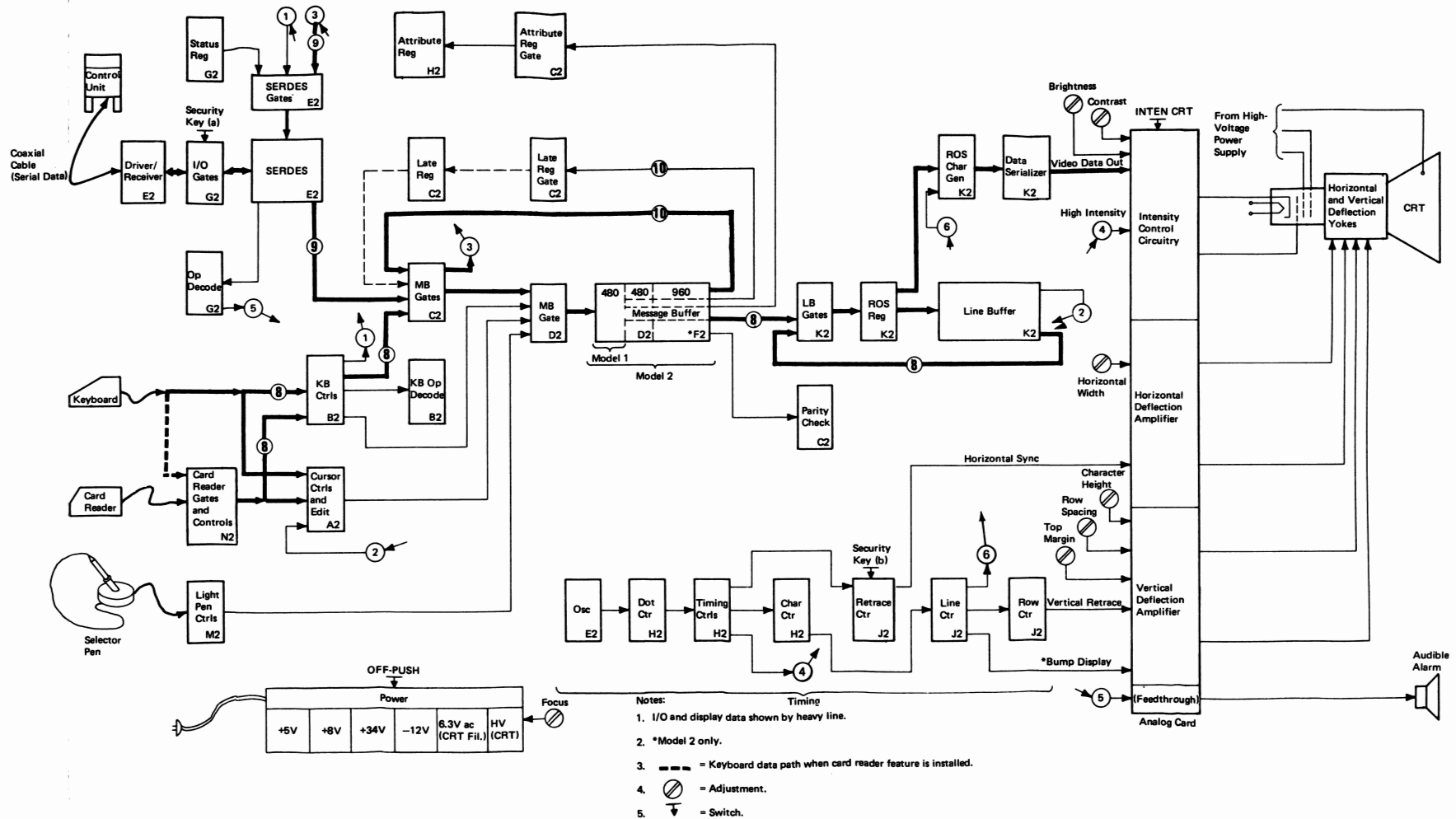

Figure 5-1. 3277 Data Flow

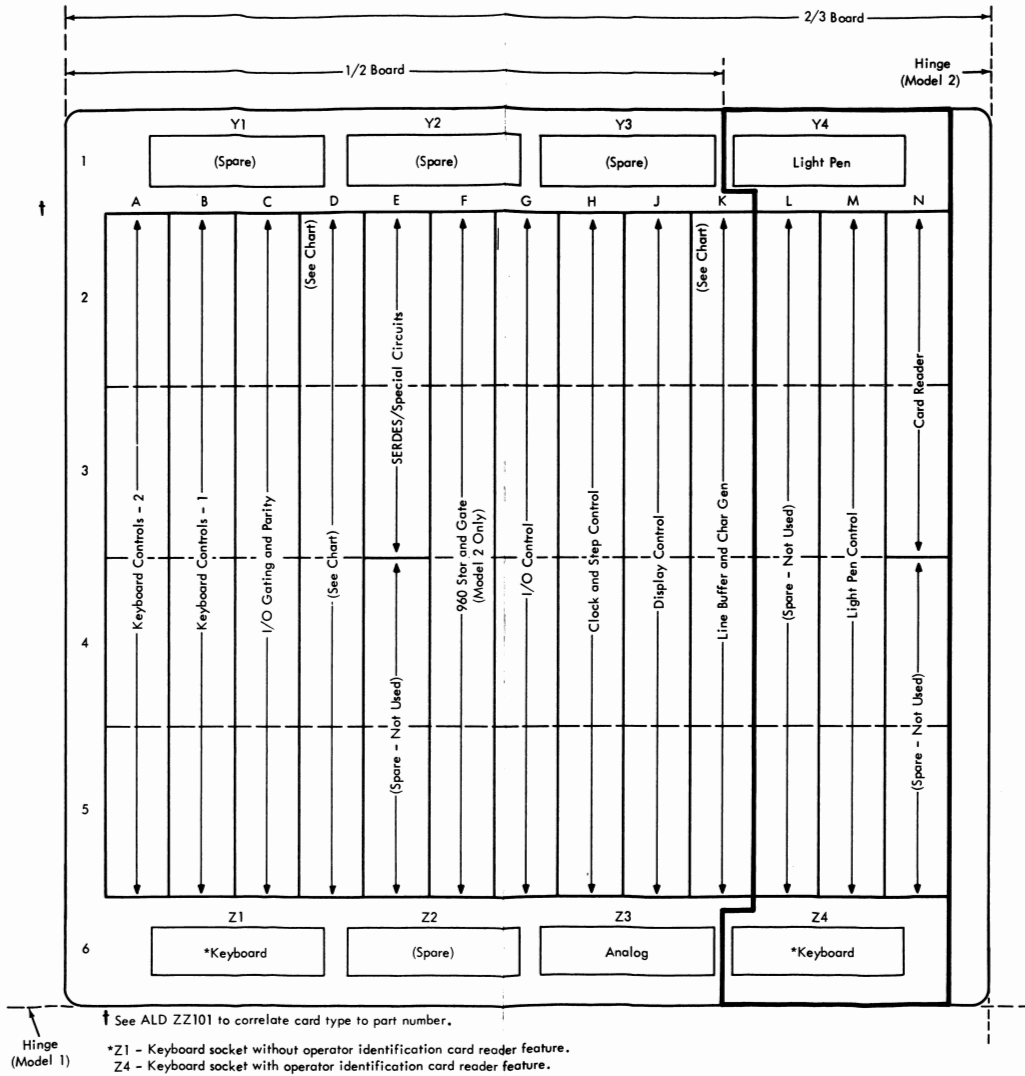

Figure 5-2. 3277 A-Gate Card Layout by Function

## 3277 CARD SUBSTITUTION LIST

The following is a card substitution list to be used for 3277 Display Stations.

### Key

- Mand = Mandatory EC  
 Opt = Optional EC  
 CC = Needs Companion Card  
 BW = Needs Board Wiring  
 MR = Minimum Rework - Functionally equivalent to the PN listed immediately below it.

The Underlined PN is the latest level card.

Cards may be substituted up or down as long as board wiring (BW) is not required.

### Basic Unit

Loc	PN	Key	ECA/EC	Function/Comments
A-2	8522128		002/717492	Mand/Keyboard Adapter
A-2	8522001	CC,BW	005/718556	Opt/Keyboard Adapter
A-2	8523628	MR		Keyboard Adapter
A-2	8523616	MR	023/718969	Opt/Keyboard Adapter
A-2	8523633		023/718969	Opt/Keyboard Adapter
A-2	8527296		FO/741258	Opt/Keyboard Adapter
	<u>8528262</u>		004/743339	
B-2	8521178		002/717492	Mand/Keyboard Adapter
B-2	8522852	CC,BW	005/718556	Opt/Keyboard Adapter
B-2	8523647	MR		Keyboard Adapter
B-2	<u>8524282</u>		028/739065	Opt/Keyboard Adapter
C-2	8521992		002/717492	Mand/I/O Gating and Parity
C-2	<u>8523648</u>		032/739071	Opt/I/O Gating and Parity
D-2	<u>8521862</u>		002/717492	Mand/Buffer Card Mod 1
D-2	<u>8521863</u>		002/717492	Mand/Buffer Card Mod 2
E-2	8522013		002/717492	Mand/SERDES
E-2	<u>8527302</u>		Factory EC	SERDES
F-2	<u>8521863</u>		002/717492	Mand/Buffer Card Mod 2
G-2	8522109		002/717492	Mand/I/O Control
G-2	8522151	CC,BW	005/718556	Opt/I/O Control
G-2	8523663	MR	-	- /I/O Control
G-2	8523651	MR	-	- /I/O Control
G-2	<u>8523664</u>		029/739072	Opt/I/O Control
H-2	8521981		002/717492	Mand/Clock and Step
H-2	8522825	CC,BW	005/718556	Opt/Clock and Step
H-2	8523617		024/718790	Opt/Clock and Step
H-2	8523649		033/739066	Opt/Clock and Step
H-2	<u>8524604</u>		Factory EC	- /Clock and Step
J-2	8522014		002/717492	Mand/Display Control
J-2	<u>8522836</u>	*CC,BW	005/718556	Opt/Display Control
K-2	8520576		002/717492	Mand/Char. Generator Mod 1
K-2	<u>8524302</u>		Factory EC	- /Char. Generator Mod 1

\*PN 8522836 can be directly substituted for PN 8522014 if the function of EC is not needed.

## Feature or RPO Units

Loc	PN	Key	ECA/EC	Function/Comments
K-2	8520577		002/717492	Mand/Char. Generator Mod 2
K-2	<u>8524289</u>		Factory EC	/Char. Generator Mod 2
A-2	8522854		718558	AB3953/2260 Compatibility
A-2	<u>8523625</u>	CC	718978	AB3953/2260 Compatibility
A-2	<u>8526046</u>	CC	740388	ME0731/2260 New Line Compatibility
A2	8564132		746050	Opt Kybd Adapt
	<u>8564143</u>		747009	
B-2	<u>8522853</u>	CC	718978	AB3953/2260 Compatibility
B-2	<u>8522853</u>	CC	740388	ME0731/2260 New Line Compatibility
B-2	<u>8523639</u>	CC	718971	WD5095/Tab-to-Colon
C-2	8528272		744156	WD5095/Tab-to-Colon
	<u>8563032</u>		745473	
C-2	<u>8528272</u>	CC	744156	APL only
C-2	8563032		745473	APL text
E-2	<u>8523653</u>		718954	AB4820/5000 Foot (1 524 m) RPO
E-4	8521437			8K0366/Dual Case Mod 1
E-4	<u>8524314</u>	CC	739268	8K0366/Dual Case Mod 1
E-4	8521436			8K0366/Dual Case Mod 2
E-4	<u>8524301</u>	CC	739268	8K0366/Dual Case Mod 2
H-2	8563021	CC	744156	APL only
K-2	<u>8521708</u>	CC	739268	8K0366/Dual Case Mod 1 and 2
K-2	8520584		739268	- /Mod 1 ASCII A
K-2	<u>8524305</u>		739268	- /Mod 1 ASCII A
K-2	8520584		739268	- /Mod 1 ASCII B
K-2	<u>8524306</u>		739268	- /Mod 1 ASCII B
K-2	8520580		739268	- /Mod 2 ASCII A
K-2	<u>8524292</u>		739268	- /Mod 2 ASCII A
K-2	8520581		739268	- /Mod 2 ASCII B
K-2	<u>8524293</u>		739268	- /Mod 2 ASCII B
K-2	<u>8527979</u>		NA	APL
L-4	8523244	CC	740392	740010/Signature Retrieval
L-2	<u>8526603</u>	CC	741248	740010/Signature Retrieval

## 3277 CARD SUBSTITUTION LIST

The following is a card substitution list to be used for 3277 Display Stations.

### Key

Mand = Mandatory EC  
 Opt = Optional EC  
 CC = Needs Companion Card  
 BW = Needs Board Wiring  
 MR = Minimum Rework - Functionally equivalent to the PN listed immediately below it.

The Underlined PN is the latest level card.

Cards may be substituted up or down as long as board wiring (BW) is not required.

### Basic Unit

Loc	PN	Key	ECA/EC	Function/Comments
A-2	8522128		002/717492	Mand/Keyboard Adapter
A-2	8522001	CC,BW	005/718556	Opt/Keyboard Adapter
A-2	8523628	MR		Keyboard Adapter
A-2	8523616	MR	023/718969	Opt/Keyboard Adapter
A-2	8523633		023/718969	Opt/Keyboard Adapter
A-2	8527296		FO/741258	Opt/Keyboard Adapter
	<u>8528262</u>		004/743339	
B-2	8521178		002/717492	Mand/Keyboard Adapter
B-2	8522852	CC,BW	005/718556	Opt/Keyboard Adapter
B-2	8523647	MR		Keyboard Adapter
B-2	<u>8524282</u>		028/739065	Opt/Keyboard Adapter
C-2	8521992		002/717492	Mand/I/O Gating and Parity
C-2	<u>8523648</u>		032/739071	Opt/I/O Gating and Parity
D-2	<u>8521862</u>		002/717492	Mand/Buffer Card Mod 1
D-2	<u>8521863</u>		002/717492	Mand/Buffer Card Mod 2
E-2	8522013		002/717492	Mand/SERDES
E-2	<u>8527302</u>		Factory EC	SERDES
F-2	<u>8521863</u>		002/717492	Mand/Buffer Card Mod 2
G-2	8522109		002/717492	Mand/I/O Control
G-2	8522151	CC,BW	005/718556	Opt/I/O Control
G-2	8523663	MR		- /I/O Control
G-2	8523651	MR		- /I/O Control
G-2	<u>8523664</u>		029/739072	Opt/I/O Control
H-2	8521981		002/717492	Mand/Clock and Step
H-2	8522825	CC,BW	005/718556	Opt/Clock and Step
H-2	8523617		024/718790	Opt/Clock and Step
H-2	8523649		033/739066	Opt/Clock and Step
H-2	<u>8524604</u>		Factory EC	- /Clock and Step
J-2	8522014		002/717492	Mand/Display Control
J-2	<u>8522836</u>	*CC,BW	005/718556	Opt/Display Control
K-2	8520576		002/717492	Mand/Char. Generator Mod I
K-2	<u>8524302</u>		Factory EC	- /Char. Generator Mod I

\*PN 8522836 can be directly substituted for PN 8522014 if the function of EC is not needed.

## Feature or RPO Units

Loc	PN	Key	ECA/EC	Function/Comments
K-2	8520577		002/717492	Mand/Char. Generator Mod 2
K-2	<u>8524289</u>		Factory EC	/Char. Generator Mod 2
A-2	8522854		718558	AB3953/2260 Compatibility
A-2	<u>8523625</u>	CC	718978	AB3953/2260 Compatibility
A-2	<u>8526046</u>	CC	740388	ME0731/2260 New Line Compatibility
A2	8564132		746050	Opt Kybd Adapt
	<u>8564143</u>		747009	
B-2	<u>8522853</u>	CC	718978	AB3953/2260 Compatibility
B-2	<u>8522853</u>	CC	740388	ME0731/2260 New Line Compatibility
B-2	<u>8523639</u>	CC	718971	WD5095/Tab-to-Colon
C-2	8528272		744156	WD5095/Tab-to-Colon
	<u>8563032</u>		745473	
C-2	<u>8528272</u>	CC	744156	APL only
C-2	8563032		745473	APL text
E-2	<u>8523653</u>		718954	AB4820/5000 Foot (1 524 m) RPO
E-4	8521437			8K0366/Dual Case Mod 1
E-4	<u>8524314</u>	CC	739268	8K0366/Dual Case Mod 1
E-4	8521436			8K0366/Dual Case Mod 2
E-4	<u>8524301</u>	CC	739268	8K0366/Dual Case Mod 2
H-2	8563021	CC	744156	APL only
K-2	<u>8521708</u>	CC	739268	8K0366/Dual Case Mod 1 and 2
K-2	8520584		739268	- /Mod 1 ASCII A
K-2	<u>8524305</u>		739268	- /Mod 1 ASCII A
K-2	8520584		739268	- /Mod 1 ASCII B
K-2	<u>8524306</u>		739268	- /Mod 1 ASCII B
K-2	8520580		739268	- /Mod 2 ASCII A
K-2	<u>8524292</u>		739268	- /Mod 2 ASCII A
K-2	8520581		739268	- /Mod 2 ASCII B
K-2	<u>8524293</u>		739268	- /Mod 2 ASCII B
K-2	<u>8527979</u>		NA	APL
L-4	8523244	CC	740392	740010/Signature Retrieval
L-2	<u>8526603</u>	CC	741248	740010/Signature Retrieval

Loc	PN	Key	ECA/EC	Function/Comments
M-2	<u>8521505</u>		717492	- /Light Pen
M-4	<u>8523242</u>	CC	740392	740010/Signature Retrieval
N-2	8522108		717492	- /Card Reader
N-2	8523257		718958	- /Card Reader
N-2	8526676		740872	EF3269/Double/Triple Zero
N-2	<u>8527308</u>		741776	EF3269/Double/Triple Zero
N-2	8526964		738413	AD0129/2956-8 Card Reader
N-2	<u>8526968</u>		741112	AD0129/2956-8 Card Reader
N-2	8526681		738417	EE8197/7460-4 Card Reader
N-2	8523243	CC	740392	7U0010/Signature Retrieval
N-2	<u>8526604</u>	CC	741248	7U0010/Signature Retrieval
E-2	<u>8527302</u>			Lightning Protection RPQ 8K0566

For maximum flexibility in stocking or controlling the card caddy, all 3277s should be brought up to ECA 005 since that is the last EC requiring board wiring. Also, an analog card (PN 2568924), latest level MLTG, and the 3270 Service Aids should be in every card caddy.



**3277 Model 1 and 2 EC Cross-Reference**

This chart (Figure 5-3) is to be used to determine the need for any of the optional EC changes and to verify the EC level of any machine. To aid in determination the serial number that implemented each change is listed. This list will be updated periodically. It is recommended that a copy of this service aid be kept in 3270 card caddies.

ECA	EC	REA	Pre-Req ECA	Concur or Comp	Opt/Mand	Feature Affected	Break In Serial #	Cards Affected		Board Wiring Involved	Card Loc	Card Type	Description
								Old P/N	New P/N				
001 (Mod 1 & 2)	716959	None	None	With ECA 002	Mand	Logic Base	10124 (Mod 1)  50235 (Mod 2)	N/A	N/A	Yes	N/A	N/A	Installation instructions and Field B/Ms will ship as part of EC 717492.
002 (Mod 1 & 2)	717492	0660110 0660121 0660124 0660125 0660126 0660129 0660133 0660135 0660137	Picks up EC 716959	With ECA 001	Mand	Logic Base	10603 (Mod 1)  50979 (Mod 2)	N/A	N/A	Yes	N/A	N/A	This change brings all early ship machines to a base EC level.
003 (Mod 1)	718601	None	None	None	Opt	Logic Base	12969	2565236	2565080	Yes	N/A	N/A	Analog cable ground wire – needed to change from old analog card P/N 2565236 to new analog card P/N 2565080.
003 (Mod 2)	717563	None	None	None	Mand	Logic Base	50235	2565236	2565080	Yes	N/A	N/A	Analog cable ground wire needed to change from P/N 2565236 card to P/N 2565080 card.
004	717946				Opt	Logic Base	12400 (Mod 1)  50979 (Mod 2)	N/A	N/A	None	N/A	N/A	New "max pack" logics shipped as part of EC 718556.
005	718556	0660138	ECA 002 EC 717492	Companion with 3271172 B/M 1838163	Opt	Logic Base	15352 (Mod 1)  57165 (Mod 2)	8522128 8521178 8522109 8521981 8522014	8522001 8522852 8522151 8522825 8522836	Yes	A1A2 A1B2 A1G2 A1H2 A1J2	9072 9069 9068 * 9071 * 9067	Remove backspace blinking, correct keyboard compatibility and correct data entry functional problems.  * Note: Card type 9068 and 9071 have no functional change – P/N change only. No parts will be shipped. P/Ns are interchangeable.
006	718399	None	None	None	Opt	None	14717 (Mod 1)	N/A	N/A	None	N/A	N/A	To extend cable length when new analog card (P/N 2565080) is installed. Note: Wiring change is on cable assembly 2577735.

Figure 5-3 (Part 1 of 6). 3277 Model 1 and 2 EC Cross-Reference Chart

ECA	EC	REA	Pre-Req ECA	Concur or Comp	Opt/ Mand	Feature Affected	Break In Serial #	Cards Affected		Board Wiring Involved	Card Loc	Card Type	Description
								Old P/N	New P/N				
006	717572	None	None	None	Mand	None	50112 (Mod 2)	N/A	N/A	None	N/A	N/A	Power Switch Actuator Guard
007	718396	None	None	None	Mand	None	56239 (Mod 2)	N/A	N/A	None	N/A	N/A	Analog arc suppressor Mod 2 only with analog card asm. P/N 2565236.
008	718348	None	None	None	Mand	Keyboard	12689 (Mod 1)  53503 (Mod 2)	N/A	N/A	None	N/A	N/A	Keyboard audible feedback asm failures caused by residual magnetism. Type A keyboard only.
009	718342	None	None	None	Opt	Keyboard	14934 (Mod 1)  56500 (Mod 2)	N/A	N/A	None	N/A	N/A	Redesigned clicker card for audible feedback asm. Type A keyboard only.
010	718613	None	None	None	Opt	None	14427 (Mod 1)	N/A	N/A	None	N/A	N/A	This EC reduces the low-frequency noise level caused by the ferro.
010	718868	None	None	None	Opt	None	55825 (Mod 2)	N/A	N/A	None	N/A	N/A	This EC reduces the low-frequency noise level caused by the ferro. On all 3277 Mod 2s previous to S/N 55825.
011	718611	None	None	None	Opt	None	18979 (Mod 1)	N/A	N/A	None	N/A	N/A	Reduce high-frequency noise caused by yoke and analog cards.
011	718869	None	None	None	Opt	None	65814 (Mod 2)	N/A	N/A	None	N/A	N/A	Reduce high-frequency noise caused by yoke and analog cards.
012	718335	None	None	None	Mand	None	18164 (Mod 1)  63338 (Mod 2)	N/A	N/A	None	N/A	N/A	Updated IR Code Guide Form No. S229-7018-1
013	718610	None	None	None	Mand	Logic Base	15157 (Mod 1)	N/A	N/A	None	N/A	N/A	Provide CRT arc suppressions to prevent damage to analog card P/N 1565236.

Figure 5-3 (Part 2 of 6). 3277 Model 1 and 2 EC Cross-Reference Chart

ECA	EC	REA	Pre-Req ECA	Concur or Comp	Opt/Mand	Feature Affected	Break In Serial #	Cards Affected		Board Wiring Involved	Card Loc	Card Type	Description
								Old P/N	New P/N				
014	738620B	None	None	None	Mand	Logic Base	18950 (Mod 1)	N/A	N/A	None	N/A	N/A	Replace defective line cord.
014	738620A	None	None	None	Mand	Logic Base	65424 (Mod 2)	N/A	N/A	None	N/A	N/A	Replace defective line cord.
015	738403	None	None	None	Opt	Mech. Group B/M	19782 (Mod 1)	N/A	N/A	None	N/A	N/A	Install foam strip to front cover to improve the retention of I/O cables.
016	738628	None	None	None	Opt	Mech. Asm 50-60 Hz		N/A	N/A	None	N/A	N/A	Replace defective detent spring.
017	739021	None	None	None	Mand	Mech. Asm 50-60 Hz	65850 (Mod 2)	N/A	N/A	None	N/A	N/A	To prevent burning of 5V return connections.
018													No EC will ever be assigned.
019	738401				Mand								World Trade only.
020	738622				Mand								World Trade only.
021	718971	None	None	None	Mand	RPQ WD 5095	64184 (Mod 2)	8522871 or 8523636	8523639	None	A1B2		To correct Dup key hang – when display is unformatted and REA 06-60142 has been installed.
022	738411	None	None	None	Mand	Mech. Group B/M	21893 (Mod 1)	N/A	N/A	None	N/A	N/A	To prevent connector housing separation which causes scorches and open connector lands. Install clips.
022	738639	None	None	None	Mand	Mech. Group B/M	75468 (Mod 2)	N/A	N/A	None	N/A	N/A	To prevent connector housing separation which causes scorches and open connector lands. Install clips.
023	718969	None	EC 718556 (ECA 005)	Companion B/M 1841516 3271/3272	Opt	Logic Base	20303 (Mod 1) 70867 (Mod 2)	8522001	8523616 or 8523633	None	A1A2	9072	Alphameric character duplicate characters with depression and release of key.
024	718970	None	None	None	Opt	Logic Base	20664 (Mod 1) 72237 (Mod 2)	8522825	8523617	None	A1H2	9071	Correct high-intensity nondisplay problem when F/S is in last character position.

Figure 5-3 (Part 3 of 6). 3277 Model 1 and 2 EC Cross-Reference Chart

ECA	EC	FEA	Pre-Req ECA	Concur or Comp	Opt/Mand	Feature Affected	Break In Serial #	Cards Affected		Board Wiring Involved	Card Loc	Card Type	Description
								Old P/N	New P/N				
025	738367	None	EC 717492 (ECA 002)	None	Mand	Card Reader Adapter	83182 (Mod 2)	N/A	N/A	Yes	N/A	N/A	To install a 2.7K ¼ watt resistor in the data strobe input circuit of card type 2229 to provide additional current in order to avoid intermittent keyboard operation.
026													No EC will ever be assigned to ECA 026.
027	718958	None	EC 718969 (ECA 023)	None	Mand	Logic Base	20303 (Mod 1) 70867 (Mod 2)	8522108	8523257	None	A1N2	2229	To correct MDT bit placement in 3277 I/O operations, and correct functional timing error.
028	739065	None	EC 718556 (ECA 005)	B/M 1841534 for 3271/72 which updates 3277 Logic	Opt	Logic Base	23878 (Mod 1) 81406 (Mod 2)	8522852	8524282	None	A1B2	9069	Correct logic to prevent multiple cursors when backtab is interrupted by backspace, period, comma, # and \$ keys.
029	739072	None	EC 717492 (ECA 002)	B/M 1841530 On 3271/72 Which Updates 3277 Logic	Opt	Logic Base	22760 (Mod 1) 77822 (Mod 2)	8522151	8523664	None	A1G2	9068	Correct logic to prevent the SERDES register from glitching during reset time. Correct logic to degate "protect buffer latch" during I/O operations.
030	738415	None	None	None	Opt	Mech. Asm 50-60 Hz		N/A	N/A	None	N/A	N/A	5 Volt return model 1.
031													Cancelled picked up on EC 740096 (ECA 035).
032	739071	None	EC 717492 (ECA 002)	B/M 1841538 Which Updates 3277 Logic	Opt	Logic Base	23738 (Mod 1) 80814 (Mod 2)	8521992	8523648	None	A1C2	9068	Correct POR logic to prevent sporadic noise from activating the POR.
033	739066	None	EC 717492 (ECA 002)	B/M 1841525 for 3271/72 Which Updates 3277 Logic	Opt	Logic Base	21455 (Mod 1) 74773 (Mod 2)	8523617	8523649	None	A1H2	9071	Correct an intermittent hang condition in the DOT CTR logic in the 9071 type card, which results in a blank screen condition. Correct error in nondisplay, high-intensity logic.

Figure 5-3 (Part 4 of 6). 3277 Model 1 and 2 EC Cross-Reference Chart

ECA	EC	REA	Pre-Req ECA	Concur or Comp	Opt/ Mand	Feature Affected	Break In Serial #	Cards Affected		Board Wiring Involved	Card Loc	Card Type	Description
								Old P/N	New P/N				
034	740659	None	None		Opt	Keyboard		N/A	N/A	None	N/A	N/A	To reduce keyboard contamination type problems by installing a new keyboard (less covers) that has a contamination shield and improved PC board. Keyboards affected will have a date code of 899 through 072.
035	740096	None	None	None	Mand.	Keyboard	26061 (Mod 1)  40482 (Mod 2)	N/A	N/A	None	N/A	N/A	Eliminate possible keyboard errors due to contamination and provide ac/dc ground separation on (Type-B) keyboards. B/M – 1655174 – All 66 key keyboard B/M – 1655175 – All 78 key keyboard
036	740098	None	None	None	Opt	Keyboard		N/A	N/A	None	N/A	N/A	This is an ECA to allow removal of (Type B) keyboards from the field which have "super slick" key modules. The key module is identifiable by its color which is white compared to the standard black module.
Continued on next page													

Figure 5-3 (Part 5 of 6). 3277 Model 1 and 2 EC Cross-Reference Chart

ECA	EC	REA	Pre-Req ECA	Concur or Comp	Opt/Mand	Feature Affected	Break In Serial #	Cards Affected		Board Wiring Involved	Card Loc	Card Type	Description
								Old P/N	New P/N				
037	739992	None	None	None	Opt	Logic Base	24956 (Mod 1)	N/A	N/A	Yes	N/A	N/A	Add several capacitor assemblies and ground jumpers to minimize shift between AC & DC ground. To protect display from damage caused by electrical storms (lightning).
037	739991	None	None	None	Opt	Logic Base	86537 (Mod 2)	N/A	N/A	Yes	N/A	N/A	Add several capacitor assemblies and ground jumpers to minimize shift between AC & DC ground. To protect display from damage caused by electrical storms (lightning).
038	739268	None	EC 717492 ECA 002	Companion B/M 1655954 3271/3272	Opt	Logic Base	24564 (Mod 1)  85047 (Mod 2)	Mono Case 8520576 (Mod 1)  8520577 (Mod 2)  Dual Case 8521437 (Mod 1)  8521436 (Mod 1)	Mono Case 8524302 (Mod 1)  8524289 (Mod 2)  Dual Case 8524314 (Mod 2)  8524301 (Mod 2)	No	K2   E4	9058 (Mod 1)  9070 (Mod 2)  2231 (Mod 1)  2227 (Mod 2)	To correct logic timing error on character gen cards causing dot size cursors. (Symptom may also start as blinking cursor.)
039	740392	06-96548  06-96549	EC 7383376	None	Mand	Signature Retrieval	28881 (Mod 1)  43507 (Mod 2)	N/A	N/A	Yes	N/A	N/A	To correct logic and modify wiring for signature display feature.
040	741691	None	None	None	Mand	Base	30649 (Mod 1)	N/A	N/A	Yes	N/A	N/A	Safety – Provide additional secondary circuit protection in case of power fault condition. Add fuses to +5 and +34 voltage lines.
040	741722	None	None	None	Mand	Base	B4083 (Mod 2)	N/A	N/A	Yes	N/A	N/A	Safety – Provide additional secondary circuit protection in case of power fault condition. Add fuses to +5 and +34 volt lines.
041	741726	None	None	None	Mand	Base	B5208 (Mod 2)	N/A	N/A	No	N/A	N/A	Safety – Provide an insulated covering over the exposed end of the hinge screw for the front cover so that when line cord is pulled, it will not accidentally short to the frame.

Figure 5-3 (Part 6 of 6). 3277 Model 1 and 2 EC Cross-Reference Chart

## 3277 SERVICE AIDS

### Analog Cards 2565236 and 2565080\*

The following procedure should be used when replacing analog cards in the 3275 or 3277 displays.

**Arcing Protection for Cathode and G1 Circuits.** (See Logic Page YA011).

1. Analog Card 2565080\* requires jumper from P4 pin 7 to frame.
  - 5" (127 mm) jumper (PN 2568928) used for 3275-1, 2 and 3277-2.
  - 8" (203 mm) jumper (PN 2577848) used for 3277-1.
2. Analog Card 2565236 requires use of spark gap assembly, PN 2568807.

For 3275-1, 2 and 3277-2, see Field B/M 2568857 at EC 718396B. 5" (127 mm) jumper (PN 2568918) from spark gap assembly 2568807 pin 3 to frame.

For 3277-1, see Field B/M 2577847 at EC 718610A. 8" (203 mm) jumper (PN 2577848) from spark gap assembly 2568807 pin 3 to frame.

3. Verify grounding of yoke shield and spring to frame.

For 3275-1, 2 and 3277-2, see Field B/M 1827666 at EC 717563B.

For 3277-1, see Field B/M 1831700 at EC 718000B.

**CAUTION:** Lack of arc protection endangers Analog Card, HVPS, Keyboard and logic cards in 01A-A1J2.

### Replacing Card 2565236 with 2565080\*

1. Remove spark gap assembly (PN 2568807) if it is installed.
2. Reconnect so that:
  - a. Cathode CRT pin 13 (yellow wire) to analog connector P4-6.
  - b. Grid 1 CRT pin 5 (white/green) to P4-4.
  - c. Frame ground jumper to P4-7.

#### Notes:

1. (3277-1 Only) If connector cabling to P3 on Card 2565080 is too short, use extender cable (PN 2577858).
2. In an emergency, 2565236 and 2565080\* are directly interchangeable. However, appropriate arc protection should be installed as soon as possible. The arc protection makes the cards permanently interchangeable.
3. Rare Case - Replacing 2565236 with 2565080\* results in vertical jitter on display. May be caused by HVPS.
4. No longer are the 5" (127 mm) or the 8" (203 mm) jumper wires being shipped with the analog cards.

### Analog Card – HV Supply

UV (Undervoltage) Line – Analog Card P3-8 to HVPS Pin 3.

1. The primary function of this line is to enable the HVPS when horizontal deflection is functioning (indicated by analog card neon). The normal operating voltage at this point (Sweep Indicator on) is approximately  $-0.7V$ . Therefore, Sweep Indicator on means HV should be on.

On the 2565236 card *only*, a second function is performed – the "+5V Switched" is sampled (P4-11); if it is absent, the UV Line will be raised to approximately +4V, thereby disabling the HVPS.

\*2568924 is the latest level analog card and replaces 2565080.

2. When UV line is removed from pin 3 of HVPS, the voltage reading on the wire from the Analog Card depends on the part number of the card. With Sweep Indicator on, the correct readings are:

2565236	Approximately	-15V
2565080	Approximately	-80V
2568924	Approximately	-80V

Note that 2565236 could have +4V on this wire for two reasons: No "+5V switched" to analog card, or analog card is defective.

3. Prior to replacing a defective analog card, a resistance check should be made on the HVPS as follows:
- Power down 3277/3275.
  - Remove wires from pins 3 and 4 (undervoltage) of HVPS.
  - With meter on X10 scale, measure resistance in both directions. The meter should NOT indicate a short or open condition (you are measuring across a diode). The actual reading will vary from meter to meter. A short will damage analog card PN 2565236 only. If a short or open is indicated, replace the HVPS.
4. Undervoltage check. The purpose of the UV line is to enable the HVPS when horizontal deflection is operating.
- Normal voltage is approximately -0.7V with wire connected to HVPS pin 3 neon on.
  - With wire removed from HVPS, pin 3 analog card PN 2565236 should measure -15V on the wire. Analog card PN 2565080\* should measure approximately -80V on the wire.
5. If approximately +4V is measured on the UV wire (2565236 only), the analog card is defective or the +5V switched to analog card is missing. +5 switched can be checked at analog connector P4-11.

#### Other Analog Troubleshooting Hints

- Predominant analog card failure causes severe loading of +34V supply which may blow F1. Isolate by pulling P3 from analog card.
- Power-On-Reset signal to logic gate is generated on analog card by sampling +400V from HVPS. Note that "+5V switched" is also required on analog cards for this function. Watch for loose Z3 connector.
- Watch for loose T0-5 heatsinks on analog card which may shake loose. Slight bend of tab will increase tension sufficiently.

#### Multiple Characters

A character is presented on the display with the depression of a key, and a duplicate character appears when the key is released.

If you are displaying duplicate characters from a single key operation, the following may be the temporary fix.

Place a 1000-ohm resistor, 1/4 watt or larger, from A02 M10 to A (+5 pin).

#### Interchangeable Data Entry and Typewriter Keyboards

Without EC 717946, keyboards are not interchangeable between typewriter and data entry 3277s unless the proper jumpering on the logic board is performed. Jumpering can be checked with logic page ZZ101 in the logic binder or page 6-13 in the 3277 troubleshooting guide.

\*2568924 is the latest level analog card and replaces 2565080.

## Defective Line Cords

Intermittent line cords causing loss of display.

The female end of the power cord which plugs into the unit can either intermittently make and break contact or not make contact at all. This condition can exist without any physical movement of the unit or cord. If you are experiencing a loss of display or raster problem, be sure this is not the defect before replacing any parts.

A temporary solution to fix a defective plug is to form the female connectors with your vise grip so they are slightly out of round and will make better contact to the male prongs.

### CAUTION

Do this only with the line cord disconnected from the ac power source. A mandatory E.C. was released to the field to correct this condition. It is ECA 014, EC 738620A and 238620B.

## Contamination Problems on Type B Keyboards

Recent Type B keyboards have several improvements which reduce problems resulting from dirt or contamination. Older Type B keyboards can be upgraded through one of the 3277 ECAs listed below:

ECA 034 – The purpose of the ECA is to reduce keyboard contamination type problems by installing a new keyboard assembly that has a contamination shield and improved PC board. The affected keyboards are easily identifiable by a three-digit handwritten date code located on the lower front corner of the all-key assembly. Keyboards affected will have a date code of 899 through 072. Keyboards other than a date code of 899 through 072 are not affected. Listed below are the affected part numbers and applicable FBMs:

PN	FBM
1858506	5187006
1858507	5187007
1858508	5187008
1858509	5187009
1858510	5187010
1858511	5187011

ECA 035 – This EC will eliminate possible keyboard errors due to contamination and provides ac/dc ground separation. The change is optional and must be ordered if needed. B/M 1655174 covers all 66-key keyboards and B/M 1655175 covers all 78-key keyboards.

ECA 036 – This ECA allows the replacement of keyboard assembly with white key modules. Color of modules may be determined by looking under keybuttons at retain lip of key module. If white, this ECA applies to the replacement of them.

All of these ECAs are Code 33.

The following is also a list of ECAs on the 3275s which have keyboards that could possibly have these same type of problems. They are: ECA 041, 042 and 043.

You are reminded that Type B keyboards are field repairable. Repair procedures are in the 3277 MLTG and parts are available through the Parts Center.

## Air Flow Restrictions

Placement of materials over top vents and/or beneath unit severely restricts air flow. The 3275 and 3277 rely on convection air flow for proper cooling of internal FRUs. The placement of materials over the top vents and/or beneath the unit severely restricts required air flow and causes overheating of components. Instruct operators to refrain from any procedure that causes a restricted air flow condition.

You are also reminded that no material (such as an IR Pack, Troubleshooting Guide, etc.) is to be stored inside of the display unit. This would both restrict air flow and constitute a safety hazard.

### CAUTION

Replacing a blown +5V or +34V fuse will cause a capacitor discharge to occur.

1. If the new fuse is placed into the fuse clip in a normal manner, it is possible for a slight arc to occur.
2. If you accidentally short the +34V fuse between the +34V and +5V fuse holder, or ground, a larger arc can occur.

Fuse puller (PN 452397) or equivalent should be used when installing or replacing fuses.

## New PC Board Part No. for Type B Keyboards

The following is a list of updated part numbers for PC boards which are not listed in the 3275/3277 Parts Catalog (S126-0005):

Keyboard	Old PN	New PN	Latest PN
66-Key EBCDIC	1860840	1643280	1865280
66-Key ASCII	1860841	1643281	1643207
Data Entry	1860842	1643282	1865281
Data Entry 2	1863842	1643283	1865282
78-Key EBCDIC	1860843	1643286	
78-Key ASCII	1860844	1643287	
1052-7	1860845	1643288	

## Part No. Change

The part number for the Arc Suppression Card Assembly on the 3277 Mod 1 has changed from 2577742 to 2577860. They are interchangeable.

## Screen Blanking

To reduce the possible replacement of analog cards and HVPS because of intermittent relay failures on E2 card (PN 8522013) in 3277s.

The symptom of intermittent screen blanking can be caused by a defective E2 card. This can be checked out quickly by tapping the E2 card. If, when tapping the card, you get a quick flashing of the data on the screen, but no total blanking, the E2 card is OK. However, when tapping this card you get a blank screen; this could indicate relay failures and the E2 card should be replaced.

## Installation of PN 2577718 in Wrong Location

**SYMPTOM:** Intermittent response from system.

**CAUSES:** Unnecessary cleaning of keyboards.

Check for proper installation of bushing as follows:

1. Turn OFF power.
2. Remove front and right side cover.
3. Disconnect coax cable from display.
4. Open gate.

5. Check to see if coax connector is isolated from casting. The coax connector is mounted correctly if there is no continuity.
6. If there was continuity between the coax connector and the casting, then PN 2577718, bushing, is either missing or mounted wrong. Refer to 3277 Parts Catalog for proper installation of the bushing.

### Lightning Protection

In lightning-prone areas, the following modifications should be made on 3277s to reduce possible component damage:

1. Add ECA 037. This ECA provides capacitor assemblies and ground jumpers to minimize the shift between ac and dc ground. Factory break in serial numbers for this ECA on the 3277 are:

3277 Model 1 – 24956

3277 Model 2 – 86537 (all 40,000 series units have this ECA installed)

2. Add RPQ 8K0566. This RPQ provides a circuit modification on the 3277 by adding a new E2 card (PN 8527302) and adds new device adapter cards (PN 8527294) to the 3271 and 3272 Control Units.

This RPQ is included on all 3277s built after 5/16/75. Factory break in serial numbers for this RPQ on the 3277 are:

3277 Model 1 – 31116

3277 Model 2 – C0221

*Note:* This RPQ is not compatible with 5000-foot (1 524 m) RPQ AB4820.

### PC Board PNs For RPQ Keyboards

RPQ Name	RPQ No.	PC Board PN
Numeric Pad	WD0760	1643289
2260 Style	8K0407	1643284
NRT	Z09005	1748102
Adding Machine	EF0436	1748112
Double/Triple Zero	EF3269	1748156

### Feature MES Keyboard PNs and Replacement Assembly PNs

Type	KEYBOARD PN (with covers MES)	KEYBOARD PN (W/O covers)
78-Key EBCDIC	1825029	1858507
78-Key ASCII	1825032	1858509
1052-7 (Console)	1825033	1858510
66-Key EBCDIC	1825028	1858506
66-Key ASCII	1825031	1858508
Data Entry	1825030	1858511
Data Entry	1655139	1863828

### RPQ KEYBOARD

Numeric Pad (WD0760)	1832722	1865180
2260 Style (8K0407)	1836442	1864390
NRT (Z09005)	1655181	1748100
Adding Machine (EF0436)	1655182	1748113
Double/Triple Zero (EF3269)	1655199	1748155

## Type A Keyboard PNs for 3277

Type	Keyboard PN (with covers MES)	Keyboard PN (W/O cover)
66-Key EBCDIC	2621364	5995515
66-Key ASCII	2621367	5995528
Data Entry	2621366	5995523
78-Key EBCDIC	2621365	5995519
78-Key ASCII	2621368	5995529
1052-7 (Console)	2621369	5995527

### RPQ KEYBOARD

Adding Machine Format (EB2788)	1836424	1855922
-----------------------------------	---------	---------

## 3277 Ship Group

Listed below is what to expect in the 3277 Shipping Group.

### HARDWARE KIT

PN	Description	Quantity
104294	Clamp-Mod 2 only	One
5756324	Label IBM	One
5756348	Holder	One

### DOCUMENTATION

Packing/Unpacking Instructions  
MLC History

### MANUALS

None — a 3277 Troubleshooting Guide is sent with each control unit.  
— one set of 3277 ALDs is sent with each control unit. (B/M2565065)

### REFERENCE BOOKLETS

None — A packet of blank IRs is sent with the control unit for use with the displays.

### KEYBOARD (if ordered)

### LINE CORD

### FEATURE DOCUMENTATION

Feature	Form No.	Title
Card Reader	SY26-4188	IDR-M Theory Maintenance Manual and Parts Catalog included

## RPQ DOCUMENTATION

RPQ No.	Form/Part No.	Title
8K0366 (Dual Case)	SY27-2345	Troubleshooting Guide
AB3953 (2260 Compatibility)	5922917	Logic Sheet ZZ102
WB5095 (Tab to Colon)	2568965	Installation Instructions
FB0760 (Security Radiation Control)	SY27-2358	Logic Sheet ZZ103 Troubleshooting Guide
8K0438 Signature Display	SY27-2357	

## SPECIAL DOCUMENTATION

3277-Mod I Documentation for Sys 3 Mod 15 Machines. Feature No. 9590.

PN	Description/Title
2565025	System Diagram
2577899	Mask
SY27-2314	3277 MLTG
GA27-2750	Problem Determination Guide
S126-0005	Parts Catalog
IR PACK WITH BLANK FORMS	
LOGIC MANUAL – 3277 – MAX PAC (B/M 2565025)	

### 3277 Board PN List

- (1/2) – Indicates 10-card position board  
(2/3) – Indicates 13-card position board.

## BASIC UNIT

PN	Latest EC Level	Description
2625204	717946	(1/2) Base Board, No Features
2625206	717946	(2/3) Base Board With Features

## RPQs

PN	Latest EC Level	Description
2625208	717946	(1/2) Dual Case, No Other Features
2625210	717946	(2/3) Dual Case With Other Features
1655978	740876	(2/3) 7460-4 Card Reader
1738806	741776	(2/3) Double/Triple Zero
1655958	740392	(1/2) Signature Retrieval, No Other Features
1655960	740392	(2/3) Signature Retrieval Feature
1655978	739260	(2/3) 2956-8 Card Reader

### **High-Frequency Noise**

Loud high-frequency noise from the display station may be reduced by tightening the heatsinks on the analog card.

If the noise problem continues and is unacceptable at the particular operating location, replace the analog card with the more recently released analog card PN 2568924.

### **Selector Pen Replacement of Tip**

If the black tip, PN 2570128, on the Selector Pen, PN 2570100, is damaged, it can be replaced by obtaining the part from Mechanicsburg or distribution centers.

## Section 6. 3284/3286 Printer

### Contents

<b>3284/3286 Symptom Fix List</b>	6-3
Printer Status Errors	6-3
Power On Reset (POR) and Printout Errors	6-3
Character Print Failures	6-4
Message Printout Errors	6-5
Platen Indexing Failures	6-6
Miscellaneous Failures	6-6
<b>3284 and 3286 Model 1 and 2 Card Substitution List</b>	6-11
Basic Unit	6-11
Features and RPQs	6-12
<b>3284 and 3286 Model 3 Card Substitution List</b>	6-13
Basic Unit	6-13
Features and RPQs	6-14
<b>3284 and 3286 Model 1 and 2 EC Cross-Reference</b>	6-15
<b>3284 and 3286 Model 3 EC Cross-Reference</b>	6-17
<b>3284 Model 1, 2, and 3 EC Cross-Reference</b>	6-19
<b>3286 Model 1, 2, and 3 EC Cross-Reference</b>	6-22
<b>3284/86 Service Aids</b>	6-25
Index Failures	6-25
Index Failures — Paper Feed Assemblies	6-25
Forms Jamming	6-26
Ribbon Drive Roll (New Style)	6-30
Card Jumpering	6-30
Transducer-to-Emitter Wheel Clearance	6-30
Preferred Alternative Transducer Adjustment	6-30
Improved Glare Shield	6-34
Cover Interlock	6-34
Data Check	6-35
Crash Stopping and/or Equipment Check	6-35
+5V Power Supply Failure	6-35
Power Supply Service Information	6-35
Equipment Checks	6-36
Index Pawl Carrier Return Spring Breakage	6-36
Indexing on Power-On Reset	6-36
Safety — 3284/3286 Top Cover Window	6-37
Maintenance Monitor	6-37
Printer PC Board and MST Card Damaged	6-37
Corrections and Additions to 3284/3286 Parts Catalog S126-0006-4	6-37
Indexing Problems	6-38
VFIC RPQ Service Information	6-39
Variable Margin RPQ EB3995	6-41
Safety — DC Power Cable	6-41
Too Many Jumper Pins on Card PN 8523248	6-41
5's and/or 9's Printing for NL or EM Orders	6-42
ALD Version Level Feature Identification	6-42
Stepper Motor and Speed Adjustment Service Hints	6-42

MLTG Updates . . . . .	6-43
Ribbon Jamming or Feeding Problems . . . . .	6-43
Ribbon Drive Roll . . . . .	6-43
Installation Instructions . . . . .	6-44
Variable Margin RPQ EB3995 Parts Information . . . . .	6-44
Forms Tractor RPQ WD4031 Service Information . . . . .	6-45
Logic Boards . . . . .	6-46
<b>VFIC Forms Specifications . . . . .</b>	<b>6-46</b>
Forms Size . . . . .	6-46
Single Part Forms — Thickness Considerations . . . . .	6-46
Multipart Forms — Thickness Considerations . . . . .	6-47
Multipart Forms — Fastening Considerations . . . . .	6-47
Index Mark — Size and Location . . . . .	6-47
Ink-Color/Paper-Color Combinations . . . . .	6-47

## Figures

Figure 6-1. 3284/3286 Model 1 and 2 Block Diagram . . . . .	6-7
Figure 6-2. 3284/3286 Model 1 and 2 A-Gate Card Layout by Function . . . . .	6-8
Figure 6-3. 3284/3286 Model 1 and 2 A-Gate Card Layout by Function — Dual Case . . . . .	6-8
Figure 6-4. 3284/3286 Model 1 and 2 A-Gate Card Layout by Function — VFIC . . . . .	6-9
Figure 6-5. 3284/3286 Model 3 A-Gate Card Layout by Function . . . . .	6-9
Figure 6-6. 3284/3286 Model 3 A-Gate Card Layout by Function — Dual Case . . . . .	6-10
Figure 6-7. 3284/3286 Model 3 A-Gate Card Layout by Function — VFIC . . . . .	6-10
Figure 6-8. 3284 and 3286 Model 1 and 2 EC Cross-Reference Chart (2 parts) . . . . .	6-15
Figure 6-9. 3284 and 3286 Model 3 EC Cross-Reference Chart (2 parts) . . . . .	6-17
Figure 6-10. 3284 Model 1, 2, and 3 EC Cross-Reference Chart (3 parts) . . . . .	6-19
Figure 6-11. 3286 Model 1, 2, and 3 EC Cross-Reference Chart (3 parts) . . . . .	6-22
Figure 6-12. Forms Specifications (2 parts) . . . . .	6-28
Figure 6-13. 3284/3286 Transducer-Adjustment Procedure (3 parts) . . . . .	6-31
Figure 6-14. VFIC Form, Locations and Dimensions . . . . .	6-48

## Section 6. 3284/3286 Printer

Figures 6-1 through 6-7 give the locations for the 3284/3286 Printer.

### 3284/3286 SYMPTOM FIX LIST

The following Symptom Fix List is to be used to supplement the existing procedures in the MLTG.

Symptom	Fix
<b>Printer Status Errors</b>	
Attn/Dev End/UC	Refer to ECA 032
Data Check	Missing, loose or defective jumper card in A1Z2, PN 5800036.
Data Check	Replace or reseat A1D2.
Data Check	Replace or reseat A1G2, also check jumpers on A1G2.
Data Check	Defective or misassembled coaxial cable decoupling capacitor.
Data Check, and/or dropping print positions	Defective or maladjusted transducer.
Data Check with Unit Specified and/or "X" in printout	Defective buffer card, socket B4, B5, C4, C5.
Data Check, and/or dropping print positions	Defective or maladjusted transducer.
Device End occurs continually	Replace or reseat A1J2.
Equipment Check, and/or "X" in printout	Defective or maladjusted transducer. Defective printer PC board. Transducer cable grounded. Defective or misassembled coaxial cable decoupling capacitor. Reseat jumper on card A1G2. Loose wire from stepper motor to EC-4. Defective cable from 3275 to 3284.
Equipment Check inhibited when running OLT's to 3275/3284	
Intervention Required occurs when online, and/or H's printed are expanded when in offline mode	Reseat or replace A1J2 or A1E2.
Intervention Required occurs when online, yet printer operates OK when in offline mode	Bad ground on ac power cord or +24V missing at A1B3D11. Reseat or replace A1E2. +5V dc switched missing.
Intervention Required and Unit Specify	Defective or maladjusted forms motion switch, or speed adjustment.
Unit Check followed by Busy	Defective coaxial cable.
<b>Power On Reset (POR) and Printout Errors</b>	
Carriage motion erratic, garbled print	Blown driver card A1 or B1, or printer PC board.
Carrier motion erratic or noisy	Clean and lubricate lead screw and carriage support shaft.
Carriage crashes into left margin	Stepper motor coupling out-of-round.
No POR	Replace or reseat A1E2.
No POR	Missing voltage. Poor I/O cable connection.

Symptom	Fix
No POR. Erratic carriage motion, and/or carriage hangs at the right margin	Replace or reseat A1D2, A1C5 or A1B2. Defective right margin switch, margin switch cable, or cable to logic gate. Defective printer PC board. If PC board blows on 3286 again, check C1 and C2 (stepper motor capacitors) for shorts. Reverse feedback transducer short to frame or shield, or intermittent open circuit. Maladjusted print emitter.
No POR. No Print (Model 3).	Defective cable to 3275 or cable ground strap not making good contact or internal printer cable (PN 2570239) defective.
PORs unexpectedly during normal operation.	Check capacitor on A1A5D03 to A1A4D08.
No print. Offline (Model 3). No print when online. Carriage may move but no print. CE Test Pattern has incorrect number of lines.	Defective card A1L2 in 3275. Defective or maladjusted forms motion switch. Defective buffer card. Defective or maladjusted left margin switch. Broken or maladjusted index link. Replace or reseat A1H2.
No print when online. (Model 3)	Decoupling capacitor should be mounted between A1A4D08 and A1A5D03.
Offline test patterns do not print	DC voltage missing at logic board.
Offline "H" Test Pattern failure or (?) appears in "H" Test Pattern printout.	Replace or reseat A1D2, or A1E2 or A1C5. Perform transducer adjustment. Check A1G2 (A1E2 on Model 3) jumper arrangement.
Prints incorrect characters during offline test	Check buffer cards B4, B5, C4, C5 or J2.
<b>Character Print Failures</b>	
Carriage moves but no print	Replace or reseat A1H2.
Dropping dots or entire character.	Check jumpering of motor control card A1G2 (Models 1, 2) or A1E2 (Model 3). Defective or maladjusted transducer.
Garbled print or varying speed.	
Incorrect line length	
Extra dots in characters	Check dc power supply voltages.
Garbled print in evenly spaced positions across the page, forming a vertical line of bad print in the printout	Warped or crooked emitter wheel.
Garbled or missing character.	Defective character generator card J2.
No Data Check and Unit Specified, and no "X" at end of printout	
Garbled print or varying print impressions; Emitter adjustment critical, or difficult to adjust.	A1B2 defective or low output.
Prints all wires for every character.	Defective card A1J2. 12 V missing, or excessive ripple at A1 board.
Print one or more random "X" characters during normal print operation	Replace buffer cards B4, B5, C4, and C5.

Symptom	Fix
Printer speed too fast; can't slow down with adjustment.	Defective PC board in printer assembly. Defective stepper motor. Noise on DC power supply voltages. A1B2 weak or defective. Warped platen or ribbon problems.
Varying print impressions.	
<b>Message Printout Errors</b>	
Continuous printing.	Defective buffer card.
Drops character, or entire line of print.	Replace or reseal A1H2 or A1D2.
Extra characters (random).	Reseat cable at A1A3.
Left margin uneven.	Defective stepper motor. Defective or maladjusted emitters. Check motor control card jumpering: A1G2 - Models 1 and 2 A1E2 - Model 3
Losing messages on 3284/3286 printers used as alternate console.	OS alternate console support does not retry equipment checks or data checks.
New Line and End of Message orders. Prints as "5" or "9".	Buffer card B4, B5, C4, C5, or J2 (Models 1 and 2) or C2 (Model 3).
One line of data from 129 Key punch is split into two lines if the first card column contains an 8 or 9.	Defective card in printer location A1D2.
Printer hangs at left margin after one line of print.	Defective or maladjusted left margin switch.
Printer hangs at some point in print line	Defective 3272 card at 01A-A1K2. Emitter wheel out-of-round, or defective tooth. Defective buffer card.
Printer hangs up.	Defective or maladjusted emitters.
Printer repeats buffer printout.	Check power supply voltages.
Printer repeats buffer printout with an "X" printed at the end.	Check emitter cables for shorts or grounding.
Printer repeats messages on a Copy command.	Loose wire from stepper motor to EC 4. Operator error. Cursor on 3277 must be returned to position zero before hitting a copy key.
Printer repeats message in online mode. Offline test works correctly	Defective card E2.
Does not print numeric 9, Model 3 printer.	Replace or reseal 3275 card at 01A-A1L2.
Wrong character prints out.	Defective ROS character generator card: A1J2 - Models 1 and 2 A1C2 - Model 3
"X" prints and Status indicator lights. Prints "X" and "?" during test patterns.	Emitter wheel out of adjustment.
"X" prints on Model 3 printer, and/or Equipment Checks.	Emitter adjustment Defective buffer card in 3275. Bad connection at A1N4 in 3275.
"X" prints or 3275 Status indicator lights, when printer is bumped.	Loose C4 capacitor in the printer.

**Symptom****Fix****Platen Indexing Failures**

Does not eject paper when end of forms is recognized.

Prints while indexing

Stacking or paper feeding problems

Too many indexes

Too many indexes

Too many indexes

Too many indexes. Clutch detect assembly not seating properly

Too many or too few indexes

Defective or maladjusted forms motion switch.

Slow transfer of forms motion switch. Binding index solenoid.

More than 6-part forms in use, or total thickness greater than 0.018 (0.5 mm) (basic), or 0.014 (0.4 mm) with VFIC RPO.

Ground strap at the rear of the printer shorting to the index solenoid.

Maladjusted right margin switch.

Binding index solenoid. Index clutch shaft undercut by support bearings.

Not enough spring tension on index clutch release lever.

Defective clutch assembly.

Defective forms motion switch.

Replace it even if it tests good.

**Miscellaneous Failures**

CE Test Pattern failure - first part of ripple pattern is correct, but second part is a repeat of first part.

Noisy - Stepper motor chatter

Noisy - Squeaking

Noisy - (vibration, rattling, or hum)

Replace or reseal A1D2 card.

Bad PC board.

Bad stepper motor driver card.

Check cabling from logic gate to printer PC board.

Carriage support shaft requires lubrication.

Lead screw requires lubrication.

Transducer touching (nipping) emitter wheel.

Carriage assembly motor drive belt too tight. (Refer to ECA 016.)

Check for out-of-round pulleys on drive motor or carriage drive shaft. Motor should not touch frame.

Check alignment of pulleys for proper belt tracking.

Check for interference between the motor pulley, and the fan shaft bearing retaining screw.

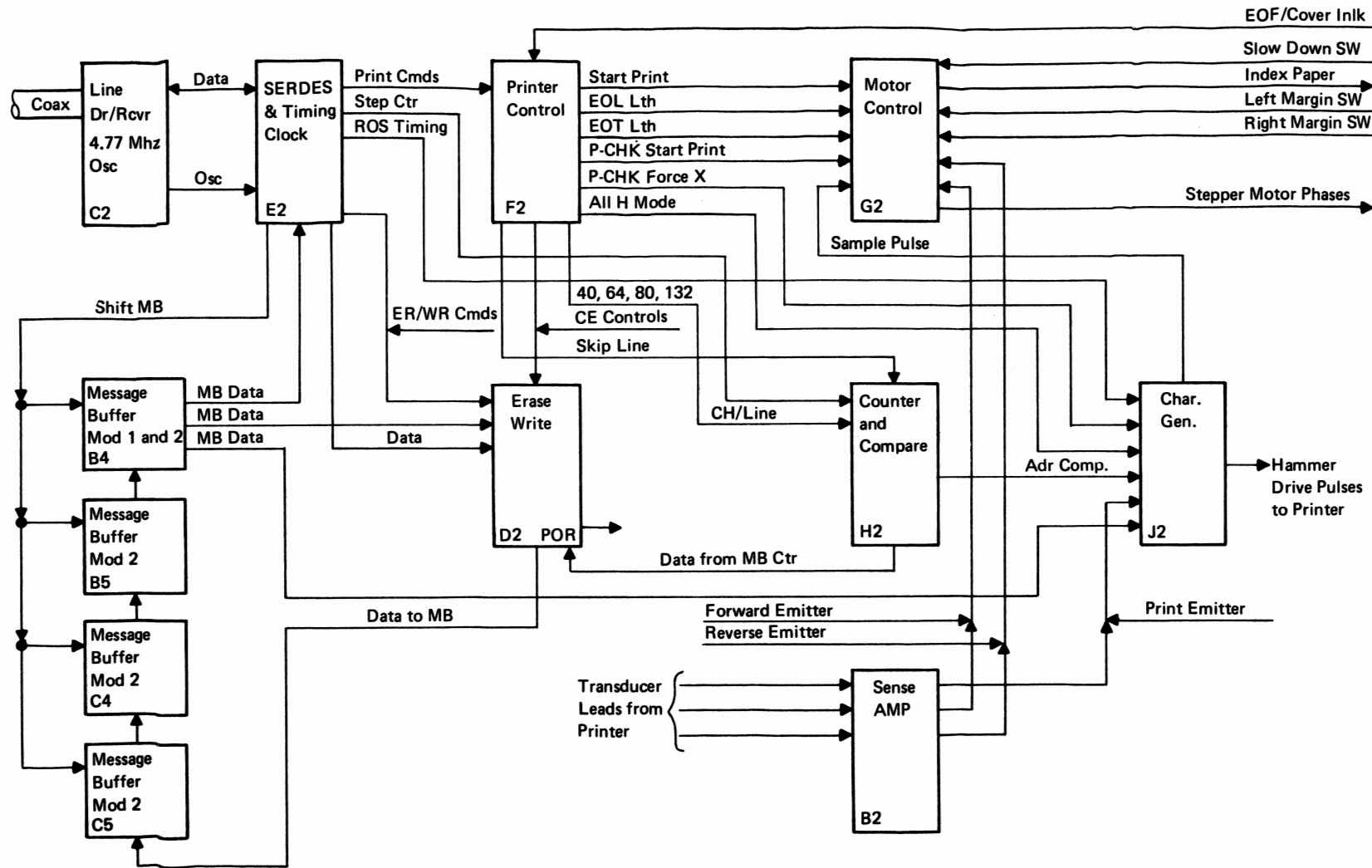

Figure 6-1. 3284/3286 Model 1 and 2 Block Diagram

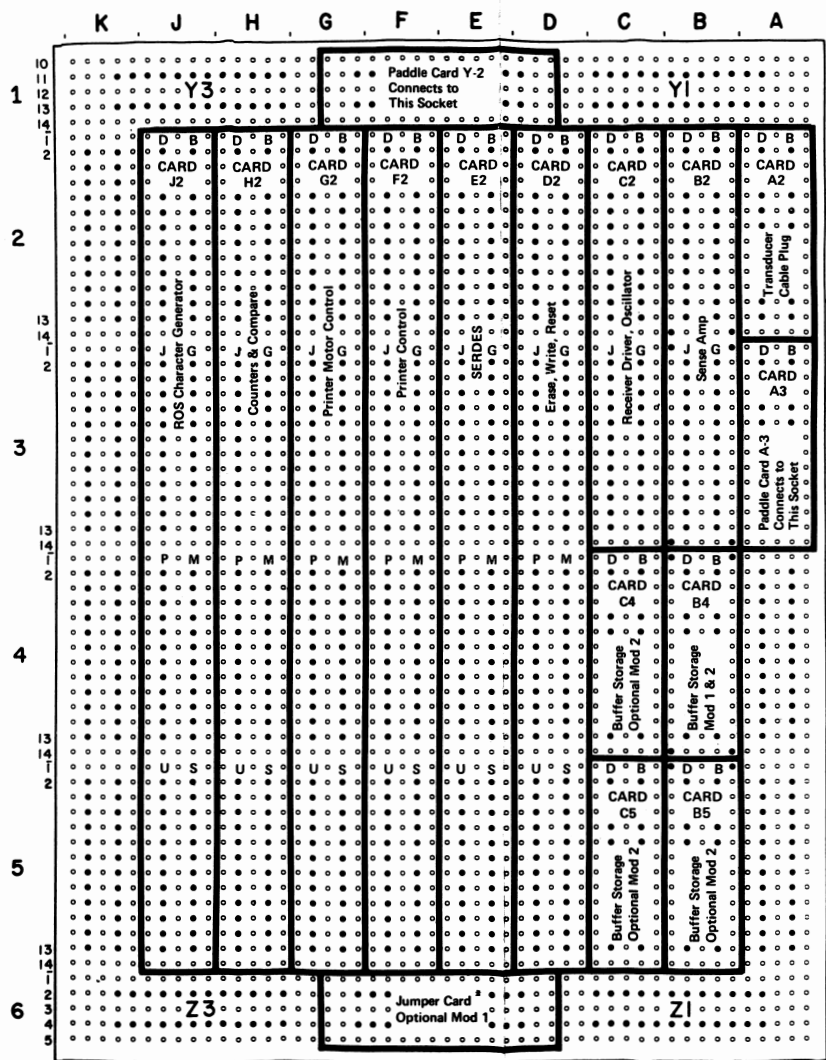

Figure 6-2. 3284/3286 Model 1 and 2 A-Gate Card Layout by Function

\* Jumper Card requires no external wiring.

1/2 Board Card Layout (Pin Side)

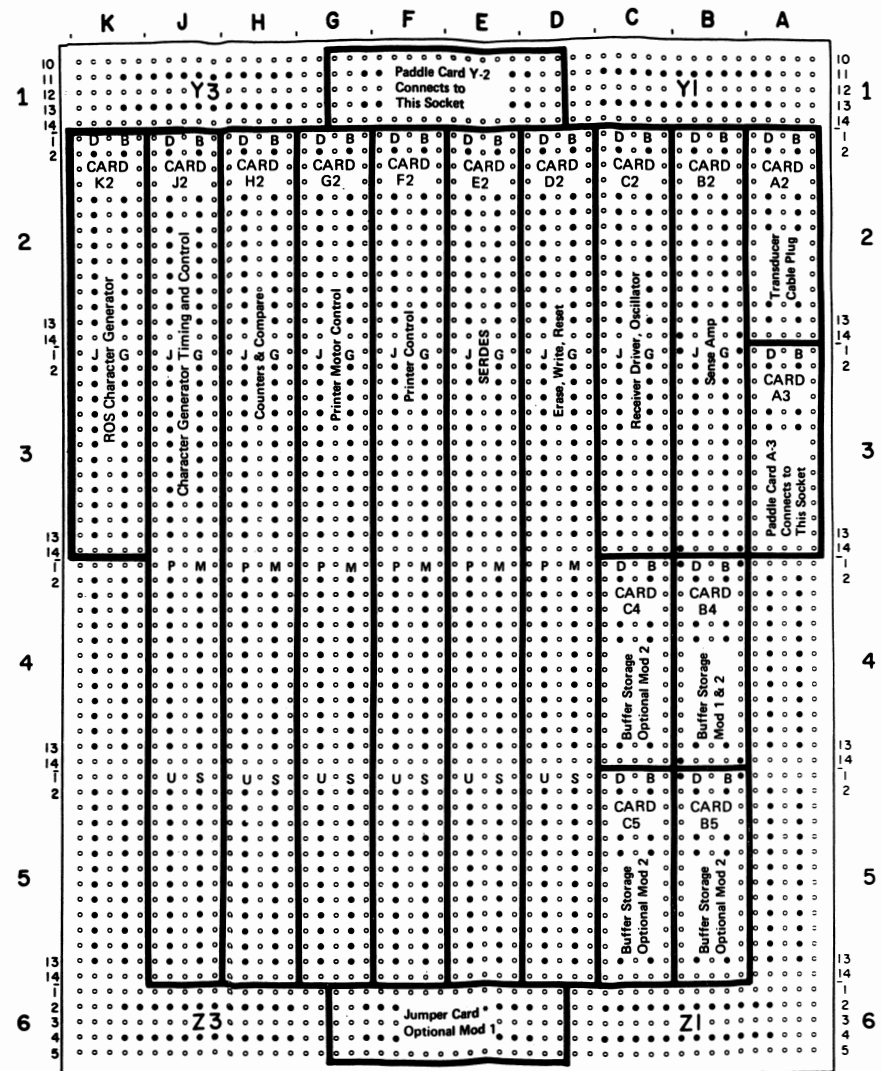

Figure 6-3. 3284/3286 Model 1 and 2 A-Gate Card Layout by Function - Dual Case

\* Jumper Card requires no external wiring.

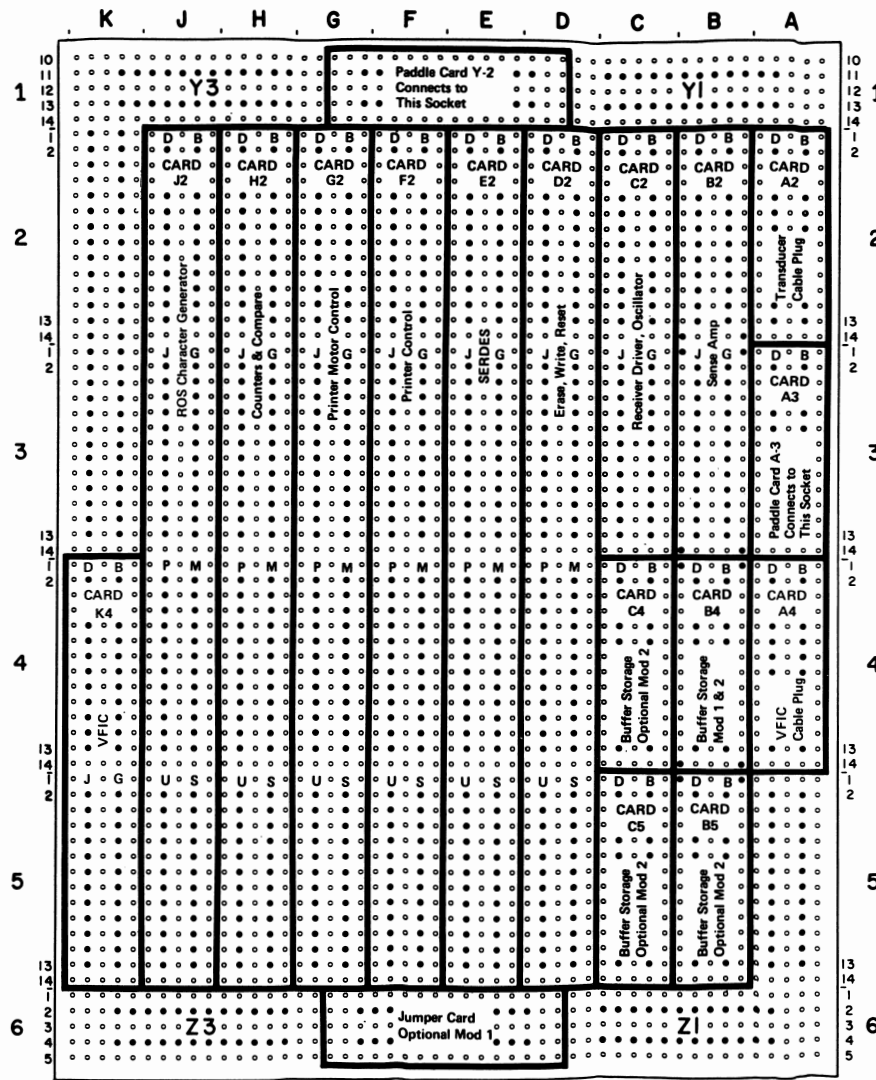

Figure 6-4. 3284/3286 Model 1 and 2 A-Gate Card Layout by Function – VFIC

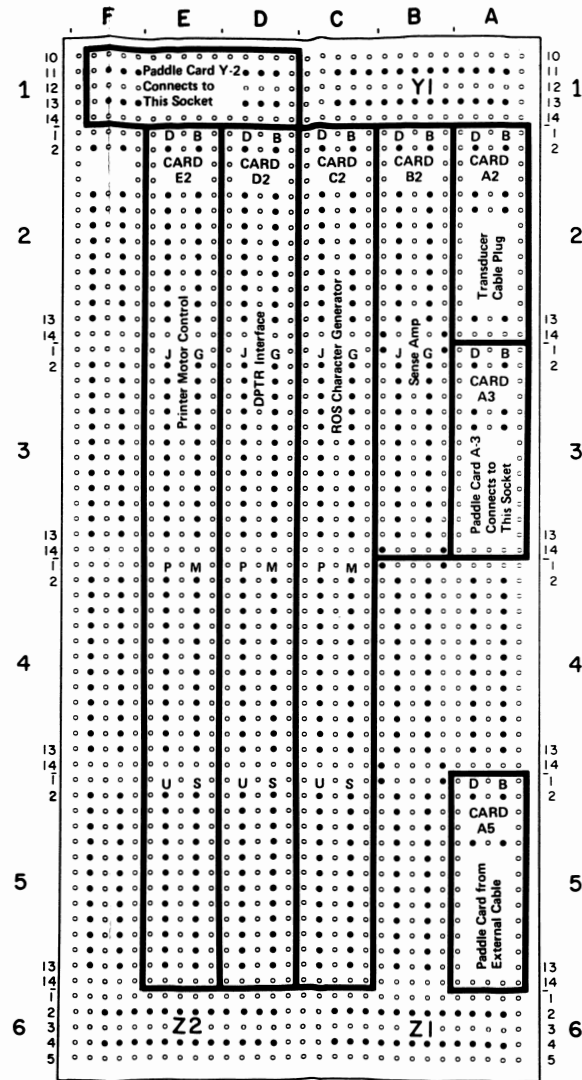

Figure 6-5. 3284/3286 Model 3 A-Gate Card Layout by Function

1/3 Board Card Layout (Pin Side)

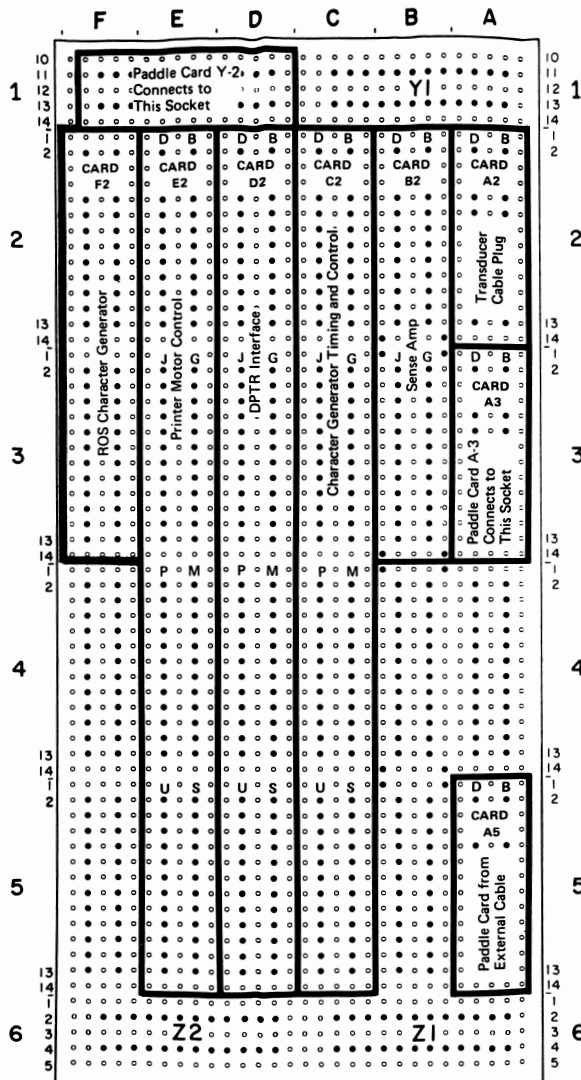

Figure 6-6. 3284/3286 Model 3 A-Gate Card Layout by Function - Dual Case

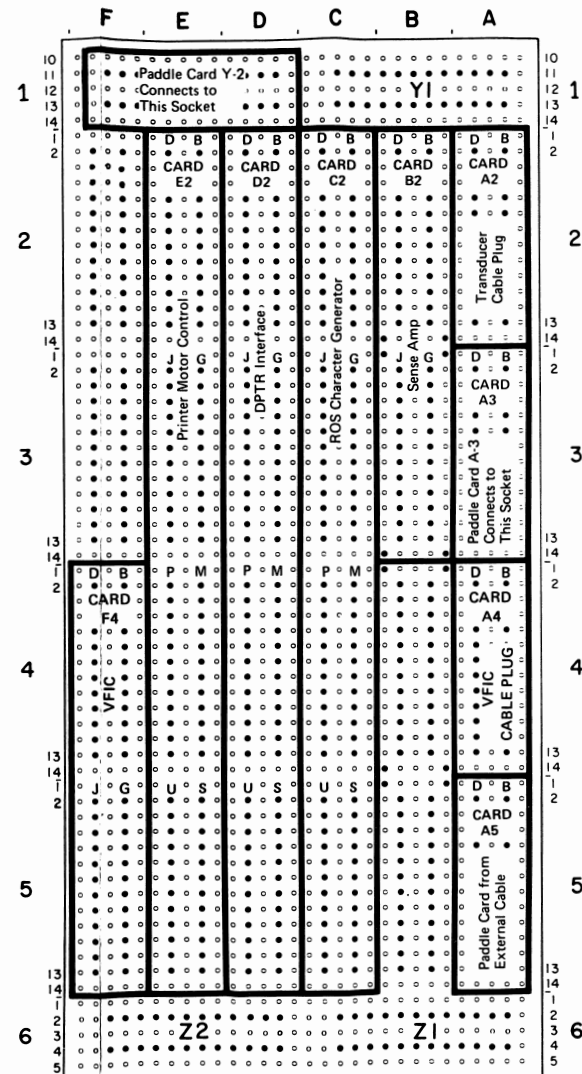

Figure 6-7. 3284/3286 Model 3 A-Gate Card Layout by Function - VFIC

### 3284 and 3286 Model 1 and 2 EC Cross-Reference

This chart (Figure 6-8) is to be used to determine the need for any of the optional EC changes and to verify the EC level of any machine. To aid in determination the serial number that implemented each change is listed. This list will be updated periodically. It is recommended that a copy of this service aid be kept in 3270 card caddies.

ECA	EC	REA	Pre-Req ECA	Concur or Comp	Opt/ Mand	Feature Affected	Break In Serial #	Cards Affected		Board Wiring Involved	Card Loc	Card Type	Description
								Old P/N	New P/N				
001	716958	63677 63678 63692 63695	None	None	Mand	Basic	3284/50050 3286/80054	8521435 8520569 8521496 8521431	8521823 8522012 8521722 8521517	Yes	A1B2 A1C2 A1D2 A1E2	9050 L511 9118 9115	Factory installed on all machines.
002	717480	None	001	None	Mand	Basic	3284/50050 3286/80054	8521722	8521731	Yes	A1D2	9118	This EC is picked up by ECA 003.
003	717487	63692 63688 63693 63694	001	None	Mand	Basic	3284/50151 3286/80171	8521041 8521517 or 8521830	8521985 8521986	Yes	A1B4 A1E2	9035 9115	Picks multiple REAs. For Model 2. Buffer cards in B5, C4, and C5 are replaced as well as B4.
004	718551	63710	003	None	Opt	Basic	3284/50801 3286/80690	8521986	8522844	No	A1E2	9115	Corrects CE test pattern failure.
005	718555	63712	003	None	Opt	Basic	3284/50966 3286/80798	8521495 or 8521698	8522850	No	A1F2	9117	Corrects intermittent missing line feeds.
006	718335	None	None	None	Mand	Basic	3284/51575 3286/81609	N/A	N/A	N/A	N/A	N/A	New IR Code Guide
007	138879	None	None	None	Mand	Basic	3284/52944 3286/82724	N/A	N/A	N/A	N/A	N/A	New carriage motion switch. Kingston EC 718336.
008	None	N/A	N/A	N/A	N/A	N/A	N/A	N/A	N/A	N/A	N/A	N/A	No EC released.
009	718977	None	003	None	Opt	Basic	3284/51615 3286/81528	8521488	8523248	No	A1G2	9113	Corrects constant indexing during POR.
010	141384	None	007	None	Mand	Basic	3284/53288 3286/83197	N/A	N/A	N/A	N/A	N/A	Install improved index link and clevis. Kingston EC 738786.
011	738791	None	None	None	Mand	Basic	3284/53249 3286/83110	N/A	N/A	N/A	N/A	N/A	Adds clips to power supply connectors to improve contact.
012	None	None	None	None	N/A	Basic	N/A	N/A	N/A	N/A	N/A	N/A	Announces the availability of an improved glare shield P/N 2495731.
013	None												World Trade Corp only.
014	141991	None	None	None	Mand	Basic	3284/53486 3286/83339	N/A	N/A	N/A	N/A	N/A	Safety change to round corners on cover P/N 2632620. Kingston EC 738795.

Figure 6-8 (Part 1 of 2). 3284 and 3286 Model 1 and 2 EC Cross-Reference Chart

ECA	EC	REA	Pre-Req ECA	Concur or Comp	Opt/Mand	Feature Affected	Break In Serial #	Cards Affected		Board Wiring Involved	Card Loc	Card Type	Description
								Old P/N	New P/N				
015	739552	69546	None	None	Opt	VFIC RPQ	3284/53899 3286/83825	N/A	N/A	Yes	N/A	N/A	Corrects VFIC counter reset problem.
016	141936	None	None	None	Opt	Basic	3284/55148 3286/85674	N/A	N/A	N/A	N/A	N/A	Reduces idling noise due to vibration.
017	None												World Trade Corp only.
018	739549	63722	003	None	Opt	Basic	3284/54363 3286/84486	8521495 or 8521698 or 8522850	8524326	No	A1F2	9117	Corrects loss of last line of CE mode. Corrects loss of last line of print "on line". Corrects switch bounce on "ready" line.
019	141990	None	None	None	Opt	Basic	3284/55440 3286/86529	N/A	N/A	No	N/A	N/A	Improved cover interlock magnet mounting bracket. Kingston EC 740361.
020	740033	63723	004	None	Opt	Basic	3284/55515 3286/86609	8521986 or 8522844 or 8523642 or 8523644	8524596	No	A1E2	9115	Corrects intermittent control checks on 3272 on SIO to a printer.

Figure 6-8 (Part 2 of 2). 3284 and 3286 Model 1 and 2 EC Cross-Reference Chart

## 3284 AND 3286 MODEL 1 AND 2 CARD SUBSTITUTION LIST

### Key

- Mand = Mandatory EC  
 Opt = Optional EC  
 CC = Companion Card required  
 BW = Board Wiring required  
 MR = Minimum Rework - functionally equivalent to PN listed immediately below it.

The underlined PN is the latest level card.

Cards may be substituted up or down as long as board wiring (BW) is not required.

### Basic Unit

Loc	PN	Key	ECA/EC	Function/Comments
B2-----	8521823		002/717480	Sense Amp
	<u>8526055</u>		030/740396	Optional EC
B4-----	<u>8521985</u>		003/717487	Buffer
B5-----	<u>8521985</u>		003/717487	Buffer Model 2
C2-----	<u>8522012</u>		003/717487	Receiver/Driver
C4-----	<u>8521985</u>		003/717487	Buffer Model 2
C5-----	<u>8521985</u>		003/717487	Buffer Model 2
D2-----	<u>8521731</u>		002/717480	Erase/Write/Reset
E2-----	8521986		003/717487	Serdes
	8522844		004/718551	Optional EC
	8523642	MR	738658	Factory EC
	8523644		738658	Factory EC
	8524595	MR	020/740033	Optional EC
	<u>8524596</u>		020/740033	Optional EC
F2-----	8521698		003/717487	Printer Control
	8522850		005/718555	Optional EC
	8524325	MR	018/739549	Optional EC
	8524326		018/739549	Optional EC
	<u>8526044</u>		023/740387	Optional EC
G2-----	8521488		003/717487	Motor Control
	8523248		009/718977	Optional EC
	<u>8526969</u>		032/741250	Optional EC
H2-----	<u>8521492</u>		003/717487	Counters & Compare
J2-----	<u>8521494</u>		003/717487	ROS Character Generator
Z2-----	<u>5800036</u>			Model 1 Jumper Card
A1A1----	5860705		NA	Print Wire Driver
	5862898		NA	
	5861753		NA	
	5863914		NA/141950	
	<u>5864333</u>		036/347554	

Loc	PN	Key	ECA/EC	Function/Comments
A1B1----	5860705		NA	Stepper Motor Driver
	5862898		NA	
	5861753		NA	
	5863914		NA/141950	
	5864333		036/347554	

### Features and RPOs

Loc	PN		EC	No./Description
C2-----	<u>8523654</u>		NA/718650	5000 Ft (1 524 m) Ext
D2-----	<u>8526960</u>		NA	APL
J2-----	<u>8521501</u>		NA/716957	Dual Case/Katakana
J2-----	<u>8526961</u>		NA	APL
J2-----	<u>8521499</u>		NA	ASCII A
J2-----	<u>8521500</u>		NA	ASCII B
K2-----	<u>8526691</u>		NA	APL
K2-----	<u>8521700</u>			Dual Case
K2-----	<u>8521518</u>			Katakana
K4-----	<u>8527300</u>		NA	APL
K4-----	8523643		NA/738659	VFIC
	8526957	BW	FO/741241	
	8527309	BW	035/742212	Optional EC
	<u>8528255</u>		045/743329	
A1A1----	5861752		NA	Dual Case Print Wire Driver
	5863915		NA/141950	
	<u>5864334</u>		036/347554	
A1B1----	5861752		NA	Dual Case Stepper Motor Driver
	<u>5864334</u>		036/347554	

## 3284 AND 3286 MODEL 3 CARD SUBSTITUTION LIST

The following is a card substitution list to be used for the 3284 and 3286 Model 3 Printer.

### Key

- Mand = Mandatory EC
- Opt = Optional EC
- CC = Companion Card Required
- BW = Board Wiring Required
- MR = Minimum Rework – functionally equivalent to PN listed immediately below it.

The underlined PN is the latest level card.

Cards may be substituted up or down as long as board wiring (BW) is not required.

### Basic Unit

Loc	PN	Key	ECA/EC	Function/Comments
B2-----	8521823		002/717481	Sense Amp
	<u>8526055</u>		031/740396	Optional EC
C2-----	<u>8521494</u>		003/717488	ROS Char. Gen
D2-----	8521833		003/717488	Ded Prtr Intf
	8522848	MR	004/717958	Optional EC
	8522829		004/717958	Optional EC
	8523615	MR	012/718968	Optional EC
	8523618	MR	012/718968	Optional EC
	8523619		012/718968	Optional EC
	<u>8526956</u>		025/740878	Optional EC
E2-----	8521488		003/717488	Motor Control
	8523248		005/718946	Optional EC
	<u>8526969</u>		NA/741762	Optional EC
A1A1----	5860705		NA	Print Wire Driver
	5862898		NA	
	5861753		NA	
	5863914		NA/141950	
	<u>5864333</u>		036/347554	
A1B1----	5860705		NA	Stepper Motor Driver
	5862898		NA	
	5861753		NA	
	5863914		NA/141950	
	<u>5864333</u>		036/347554	

## Features and RPOs

Loc	PN	EC	No./Description
C2-----	<u>8521501</u>	NA/716957	Katakana
F2-----	<u>8521700</u>		Dual Case
F2-----	<u>8521518</u>		Katakana
F4-----	8523643	NA/738659	VFIC
	8526957 BW	FO/740879	
	8527309 BW	NA/742863	Optional EC
	<u>8528255</u>	041/743334	
A1A1----	5861752	NA	Dual Case Print Wire Driver
	5863915	NA/141950	
	<u>5864334</u>	036/347554	
A1B1----	5861752	NA	Dual Case Stepper Motor Driver
	5863915	NA/141956	
	<u>5864334</u>	036/347554	

**3284 and 3286 Model 3 EC Cross-Reference**

This chart (Figure 6-9) is to be used to determine the need for any of the optional EC changes and to verify the EC level of any machine. To aid in determination the serial number that implemented each change is listed. This list will be updated periodically. It is recommended that a copy of this service aid be kept in 3270 card caddies.

ECA	EC	REA	Pre-Req ECA	Concur or Comp	Opt/Mand	Feature Affected	Break In Serial #	Cards Affected		Board Wiring Involved	Card Loc	Card Type	Description
								Old P/N	New P/N				
001	716957		None	None	Mand	Basic	3284/70034 3286/75032	N/A	N/A	N/A	N/A	N/A	Factory installed on all machines.
002	717481	None	001	None	Mand	Basic	3284/70034 3286/75032	N/A	N/A	N/A	N/A	N/A	This EC is picked up by ECA 003.
003	717488	63683 63697	001	None	Mand	Basic	3284/70196 3286/75114	8521528 8521490	8521833 8521823	Yes	A1D2 A1B2	9093 9050	Picks up multiple REAs.
004	717958	63711	003	None	Opt	Basic	3284/70579 3286/75235	8521833	8522829	No	A1D2	9093	Correct a problem of missing line feeds.
005	718946	None	003	None	Opt	Basic	3284/70791 3286/75347	8521488	8523248	No	A1E2	9113	Corrects constant paper indexing during POR.
006	138879	None	None	None	Mand	Basic	3284/71594 3286/83197	N/A	N/A	N/A	N/A	N/A	New carriage motion switch. Kingston EC 718336.
007	718335	None	None	None	Mand	Basic	3284/70995 3286/75359	N/A	N/A	N/A	N/A	N/A	New IR Code Guide
008	None	N/A	N/A	N/A	N/A	N/A	N/A	N/A	N/A	N/A	N/A	N/A	No EC released.
009	141384	None	006	None	Mand	Basic	3284/71790 3286/75435	N/A	N/A	N/A	N/A	N/A	Install improved index link and clevis. Kingston EC 738786.
010	738791	None	None	None	Mand	Basic	3284/71719 3286/75413	N/A	N/A	N/A	N/A	N/A	Adds clips to power supply connectors to improve contact.
011	None	None	None	None	N/A	Basic	N/A	N/A	N/A	N/A	N/A	N/A	Announces the availability of an improved glare shield P/N 2495731.
012	718968	None	003	None	Opt	Basic	3284/71117 3286/75381	8522829	8523619	No	A1D2	9093	Eliminate switch bounce on "ready" line to 3275 to correct loss of "device-end" status.
013	None												World Trade only.
014	141991	None	None	None	Mand	Basic	3284/71829 3286/75446	N/A	N/A	N/A	N/A	N/A	Safety change to round corners on cover P/N 2632620. Kingston EC 738795.
015	None												Not applicable to Model 3.

**Figure 6-9 (Part 1 of 2). 3284 and 3286 Model 3 EC Cross-Reference Chart**

ECA	EC	REA	Pre-Req ECA	Concur or Comp	Opt/ Mand	Feature Affected	Break In Serial #	Cards Affected		Board Wiring Involved	Card Loc	Card Type	Description
								Old P/N	New P/N				
016	141936	None	None	None	Opt	Basic	3284/72994 3286/75697	N/A	N/A	N/A	N/A	N/A	Reduce idling noise due to vibration.
017	None												World Trade only.
018	None												Not applicable to Model 3.
019	141990	None	None	None	Opt	Basic	3284/73292 3286/75794	N/A	N/A	N/A	N/A	N/A	Improved cover interlock magnet mounting bracket. Kingston EC 740361.
020	740033												Not applicable to Model 3.

Figure 6-9 (Part 2 of 2). 3284 and 3286 Model 3 EC Cross-Reference Chart

**3284 Model 1, 2, and 3 EC Cross-Reference**

This chart (Figure 6-10) is to be used to determine the need for any of the optional EC changes and to verify the EC level of any machine. To aid in determination, the serial number that implemented each change is listed. This list will be updated periodically. It is recommended that a copy of this service aid be kept in 3270 card caddies.

ECA	EC	REA	Pre-Req ECA	Concur or Comp	Opt/Mand	Feature Affected	Break In Serial #	Cards Affected		Board Wiring Involved	Card Loc	Card Type	Description
								Old P/N	New P/N				
021	740375	None	None	None	Mand	Basic	Mod 1 & 2 56859 Mod 3 73833	N/A	N/A	N/A	N/A	N/A	Provides additional secondary circuit protection in case of power fault condition by adding a +5V and +24V fuse.
022	144179	None	None	None	Opt	Basic	N/A	N/A	N/A	N/A	N/A	N/A	Prevents paper jams which are due to static electricity by replacing plastic forms guide with all metal guide.
023	740387	None	003	None	Opt	Basic	Mod 1 & 2 56087 Mod 3 N/A	8524325 or 8524326	8526044	No	A1F2	9117	Corrects a problem of loss of last buffer position if preceding 2 positions have N/L codes and printer is in default mode.
024	144173	None	None	None	Mand	Basic	Mod 1 & 2 55779 Mod 3 73516	N/A	N/A	N/A	N/A	N/A	Prevents indexing problems by replacing clutch cam set screws and by adding shims to clutch cam release arm.
025	740878	None	None	None	Opt	Basic	Mod 3 74131 Mod 1 & 2 NA	8523619	8526956	No	A1D2	9093	Corrects a problem of undefined S/S on Mod 3 printers with V/FIC by bypassing 20-ms delay between equipment check and not ready status.
026	393341												World Trade only.
027	393327												World Trade only.
028	393305												World Trade only.
029	740759	None	None	None	Mand	Basic	Mod 1 & 2 55910 Mod 3 73630	N/A	N/A	N/A	N/A	N/A	MLTG update
030	740396	003	None	None	Opt	Basic	N/A	8521823	8526055	No	A1B2	9050	Corrects the problem of machine indexing for 15 seconds when first powered "on". Models 1 and 2

Figure 6-10 (Part 1 of 3). 3284 Model 1, 2, and 3 EC Cross-Reference Chart

ECA	EC	REA	Pre-Req ECA	Concur or Comp	Opt/Mand	Feature Affected	Break In Serial #	Cards Affected		Board Wiring Involved	Card Loc	Card Type	Description
								Old P/N	New P/N				
031	740397	63726	003	None	Opt	Basic		8521823	8526055	No	A1B2	9050	Corrects problem of machine indexing for 15 seconds when first powered on. Mod 3
032	741250		003	None	Opt	Basic		8523248	8526969	No	A1G2	9113	Corrects problem of S/S errors of ATTN/Dev End/UC on 3284 connected to 3272 with 1 Dev adapt and 4 Dev.
033	742633		None	None	Opt	Basic				No			New cassette aligner and ribbon drive roll.
034	742852		021	None	Mand	Basic	Mod 1 & 2 58792 Mod 3 74662			Power Supply			Fan change to eliminate belt 24V supply change safety.
035	742212	85322	015	None	Opt	VFIC		8526957	8527309 or 8528255	Yes	A1K4	Y936	Provides adj VFIC sensitivity. Changes VFIC timeout. Provides VFIC reset. Mod 1 & 2
036	347554		None	None	Opt	Basic		5863914 or 5863915	5864333 or 5864334	No	A1A1 A1B1		Eliminates erroneous firing of print wires during POR.
037	742179		None	None	Opt	Basic				No			Adds clamp to capacitors C1 & C2 to minimize loosening.
038	347563		None	None	Opt	Basic				No			Replaces index shaft and bearings to reduce index problems.
039	740363		023	None	Opt	Basic				No			Provides Ready lamp Mod 1 & 2
040	743344		025	None	Opt	Basic				No			Provides Ready lamp Mod 3
041	740879 743334		(056) 3275 025		Opt	VFIC		8527309	8528255	Yes	A1F4	Y936	Improved VFIC reliability Mod 3 Requires ECA 056 on 3275
042	347577		None	None	Opt	Basic				No			Installs new heavy duty index link and clevis to eliminate index failures.

Figure 6-10 (Part 2 of 3). 3284 Model 1, 2, and 3 EC Cross-Reference Chart

ECA	EC	REA	Pre-Req ECA	Concur or Comp	Opt/ Mand	Feature Affected	Break In Serial #	Cards Affected		Board Wiring Involved	Card Loc	Card Type	Description
								Old P/N	New P/N				
043	349160		None	None	Opt	Basic				No			Supplies improved drive belts.
044	741113		None	None	Opt	VFIC				No			Installs forms guide and paper hold down assem to fix paper jam.
045	743329		035	None	Opt	VFIC		8527309	8528255		A1K4	Y936	Provides improved VFIC Mod 1 & 2 reliability.
046	347598		None	None	Opt	Basic				No			Provides wider emitter wheel and a more sensitive transducer to help alleviate emitter problems.
047	318253												WTC only.

Figure 6-10 (Part 3 of 3). 3284 Model 1, 2, and 3 EC Cross-Reference Chart

### 3286 Model 1, 2 and 3 EC Cross-Reference

This chart (Figure 6-11) is to be used to determine the need for any of the optional EC changes and to verify the EC level of any machine. To aid in determination, the serial number that implemented each change is listed. This list will be updated periodically. It is recommended that a copy of this service aid be kept in 3270 card caddies.

ECA	EA	REA	Pre-Req ECA	Concur or Comp	Opt/Mand	Feature Affected	Break In Serial #	Cards Affected		Board Wiring Involved	Card Loc	Card Type	Description
								Old P/N	New P/N				
021	740375	None	None	None	Mand	Basic	Mod 1 & 2 88090 Mod 3 75890	N/A	N/A	N/A	N/A	N/A	Provides additional secondary circuit protection in case of power fault condition by adding +5V and +24V fuse.
022	144179	None	None	None	Opt	Basic	N/A	N/A	N/A	N/A	N/A	N/A	Prevents paper jams caused by static electricity by replacing plastic forms guide with metal guide.
023	740387	None	003	None	Opt	Basic	Mod 1 & 2 87704 Mod 3 N/A	8524325 or 8524326	8526044	No	A1F2	9117	Corrects problem of loss of last buffer position if preceding 2 positions have N/L codes and printer is in default mode.
024	144182	None	None	None	Mand	Basic	Mod 1 & 2 88822 Mod 3 75947	N/A	N/A	N/A	N/A	N/A	Prevents PC board burnout by installing heatsinks on diodes. Prevents indexing problems by replacing clutch cam set screws and adding shims to clutch cam release arm.
025	740878	None	None	None	Opt	Basic	Mod 3 75952 Mod 1 & 2 N/A	8523619	8526956	No	A1D2	9093	Corrects a problem of undefined S/S on Mod 3 printers with V/FIC, by bypassing 20-ms delay between equipment check and not ready status.
026	393341												World Trade only.
027	393327												World Trade only.
028	393305												World Trade only.
029	740759	None	None	None	Mand	Basic	Mod 1 & 2 87370 Mod 3 75840	N/A	N/A	N/A	N/A	N/A	MLTG update.
030	740396	63725	003	None	Opt	Basic	N/A	8521823	8526055	No	A1B2	9050	Corrects the problem of machine indexing for 15 seconds when first powered "on". Models 1 and 2

Figure 6-11 (Part 1 of 3). 3286 Model 1, 2, and 3 EC Cross-Reference Chart

ECA	EC	REA	Pre-Req ECA	Concur or Comp	Opt/Mand	Feature Affected	Break In Serial #	Cards Affected		Board Wiring Involved	Card Loc	Card Type	Description
								Old P/N	New P/N				
031	740397		003	None	Opt	Basic		8521823	8526055	No	A1B2	9050	Corrects the problem of machine indexing for 15 seconds when first powered on. Mod 3
032	741250		003	None	Opt	Basic		8523248	8526969	No	A1G2	9113	Corrects problem of S/S errors of ATTN/DE/UC on 3284 connected to 3272 with 1 Device adapter & 4 Devices.
033	347568		None	None	Opt	Basic				No			New cassette aligner and ribbon drive roll.
034	347575		021	None	Mand	Basic	Mod 1 & 2 11470 Mod 3 76010			Power Supply			Fan change to eliminate belt.
035	742212		015	None	Opt	VFIC		8526957	8527309 8528255	Yes	A1K4	Y936	Provides adj VFIC sensitivity. Changes VFIC timeout. Provides VFIC reset. Mod 1 & 2
036	347554		None	None	Opt	Basic		5863914 or 5863915	5864333 or 5864334	No	A1A1 A1B1		Eliminates erroneous firing of print wires during POR.
037	742179		None	None	Opt	Basic				No			Adds clamp to capacitors C1 & C2 to minimize loosening.
038	347563		None	None	Opt	Basic				No			Replaces index shaft and bearings to reduce index problems.
039	740363		023	None	Opt	Basic				No			Provides ready lamp. Mod 1 & 2
040	743344		025	None	Opt	Basic				No			Provides ready lamp. Mod 3
041	743334		025	See Descrip.	Opt	VFIC		8527309	8528255	Yes	A1F4		Improved VFIC reliability. Mod 3 Requires ECA 056 on 3275.

Figure 6-11 (Part 2 of 3). 3286 Model 1, 2, and 3 EC Cross-Reference Chart

ECA	EC	REA	Pre-Req ECA	Concur or Comp	Opt/Mand	Feature Affected	Break In Serial #	Cards Affected		Board Wiring Involved	Card Loc	Card Type	Description
								Old P/N	New P/N				
042	743349		None	None	Opt	Basic				No			Installs new heavy duty index link and clevis to eliminate index failures.
043	743359		None	None	Opt	Basic				No			Supplies improved drive belts.
044	741113		None	None	Opt	VFIC				No			Installs forms guide and paper hold down assem to fix paper jams.
045	743329		035	None	Opt	VFIC		8527309	8528255		A1K4	Y936	Provides improved VFIC function. Increases VFIC timeout to 192 indexes & provides VFIC error reset. Mod 1 & 2
046	347598		None	None	Opt	Basic				No			Provides wider emitter wheel and a more sensitive transducer to help alleviate emitter problems.
047	318253												WTC only.

Figure 6-11 (Part 3 of 3). 3286 Model 1, 2, and 3 EC Cross-Reference Chart

## 3284/86 SERVICE AIDS

### Index Failures

Indexing failures may be due to wearing of the carriage clutch assembly shaft, PN 2495519 (Item 72, fig. 5 in 3284/86 parts catalog). Any vertical movement of the shaft indicates that the shaft and bearings (PN 114498) should be replaced. This vertical movement can be observed by lifting upon the shaft with a screwdriver while using the motor as a fulcrum. If the bearings are presently clearance-fit on this shaft (allowing the shaft to turn inside the inner race of the bearing), order ECA038, which provides B/M 1863576. Installation of this B/M requires Loctite\* sealant Type A, PN 216348, and Loctite Primer, PN 615960. Until parts are available, the problem can be solved by making the shaft swell in the area where the left bearing fits on the shaft. This can be done by striking a center punch at four spots equidistant around the circumference of the shaft. This procedure is only necessary for the bearing nearest to the motor pulley. The bearing on the opposite end of the shaft is held in place by pressing the collar (PN 2495518) against the inner race of the bearing. It is important that there be no clearance between the collar and the bearing.

### Index Failures – Paper Feed Assemblies

There are two style paper feed assemblies on 3284/86 printers presently in the field. The type of paper feed assembly on a printer can be identified by comparing the mechanical assembly serial number to that below.

The serial number is stamped in the base casting of the mechanical printer assembly directly below the right end of the print head worm shaft.

3284 base serial number below 01611 is old style.

3284 base serial number above 01610 is new (A frame) style.

3286 base serial number below 01680 is old style.

3286 base serial number above 01679 is new (A frame) style.

There are several parts which are not interchangeable between the two style paper feed assemblies, and intermittent indexing problems could result if these parts are intermixed on a machine. Consult 3284/86 Parts Catalog, Figure 8, for old style paper feed assemblies, or Figure 7 for new style paper feed assemblies. Also, the pin feed platens are not interchangeable between the different style pin feed assemblies (refer to Parts Catalog, Figure 6, item 1).

\*Trademark of Loctite Corp.

## Forms Jamming

The following is a recommended checklist if you are experiencing forms jamming problems.

1. Apply anti-static solution PN 2200118 (or equivalent) to all paper guide surfaces. Frequency dictated by environment.
2. Adjust platen laterally to ensure the forms do not contact the left edge of Forms Entry Guide.
3. Ensure that the platen pin-to-pin dimension aligns with the marginally punched holes in the forms. (Note that forms hole-to-hole dimension changes significantly with variations in relative humidity.)
4. Ensure that the platen pinwheels are adjusted per MLTG.
5. Ensure that the Forms Entry Guide is square with and parallel to the platen.
6. Ensure that Forms Stacker Stand, sales feature number 4450 or equivalent, is used with each printer. The Forms Supply Tray should be located below the Forms Stacking Tray.
7. Verify that platen height, platen-to-print head, and platen-to-ribbon guide dimensions are as specified in the MLTG.
8. Ensure the Forms Wire Guides are located per the MLTG. Additional Forms Wire Guides may be installed as required, using clamp (1) PN 2640769, bracket (2) PN 2642456, and guides (as required) PN 2642446.
9. Verify that orange shipping spacers have been removed from shock mounting for printer assembly.
10. All forms should be removed from the carton.
11. If jamming is due to static electricity on printers with a plastic exit rack (old style), install optional EC 144179 (refer to ECA 022), replacing existing rack with new metal forms exit rack.
12. Forms jamming may also be due to out-of-specification forms. Refer to Figure 6-12 for form specifications or to the *Forms Design Reference Manual*, GA24-3488.
13. If the VFIC feature is installed, see ECA044.



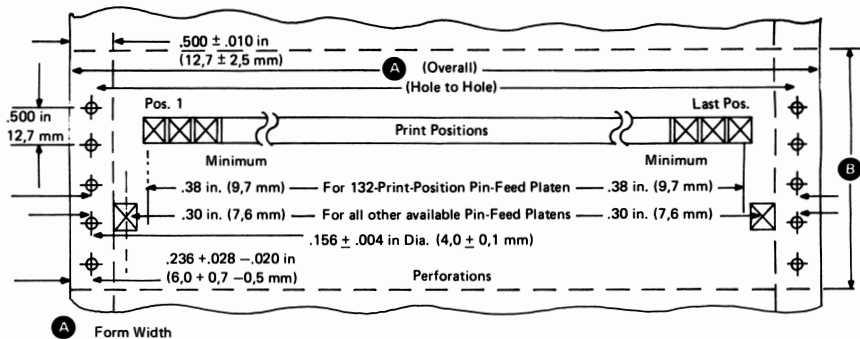

Model	Maximum Width			Minimum Width		
	Print Positions	Overall	Hole to Hole	Print Positions	Overall	Hole to Hole
3284, 3286	132	14.375 in. (365,1 mm)	13.875 in. (352, 4 mm)	120	13 in. (330,2 mm)	12.5 in. (317,5 mm)

See the *Forms Design Reference Manual*, GA24-3488, for more detail.

**Figure 6-12 (Part 1 of 2). Forms Specifications**

- **B** Form Length – 11 in. (279, 4 mm) recommended for optimum stacking

Minimum – 3 in. (76,2 mm)

Multiple Copies – Up to 6-part form can be printed.

- Front form of multiple copy must be a full form width.
- No hard fasteners.
- Maximum thickness depends on model.

Pin-Feed – Thickness .018 in. (0,46 mm) maximum. For optimum feeding and stacking no more than 3-part forms are recommended.

– Card stock not recommended.

Single-ply Roll Paper

- a. Width – up to 15 in. (381,0 mm)
- b. OD – 4 in. (101,6 mm)
- c. ID – .375 in. (9,5 mm)

*Note:* For more detailed information refer to Forms Design Reference Guide for Printers Form # GA24-3488.

**Figure 6-12 (Part 2 of 2). Forms Specifications**

## Ribbon Drive Roll (New Style)

The ribbon drive roll has been redesigned to improve the ribbon drive operation. The rubber feed rolls have been replaced by a serrated urethane feed roll assembly. The new ribbon drive shaft assembly (PN 5165590) will eliminate the need for spacer (PN 2632608) and will require a new cassette aligner (PN 2632609). The new style ribbon drive roll assembly should be installed on all 3284/86 printers presently experiencing excessive replacement of drive roll or experiencing ribbon feed problems.

1. Remove the cassette aligner (PN 2632609), the ribbon drive roll (PN 2632584), and the spacer (PN 2632608). Scrap locally.
2. Install new cassette aligner (PN 2632609). Mount aligner flush with shoulder on mounting plate.
3. Install new ribbon drive roll assembly (PN 5165590). Adjust collar for minimum end play without binding.

## Card Jumpering

An error exists in the -X and -O 3284 and 3286 MLTGs in reference to jumpering of the motor control card. Correct jumpering for the motor control card in position G2 for 3284/3286 Models 1 and 2 and E2 for 3284/3286 Model 3 is as follows:

Card PN 8521429 EC716936 for 3284 jumper 1-3

Card PN 8521488 EC717487 for 3284 jumper 2-3

Card PN 8523248 EC718946 for 3284 jumper 2-3

Card PN 8526969 EC741250 for 3284 jumper 2-3

Card PN 8521429 EC716936 for 3286 jumper 1-2

Card PN 8521488 EC717487 for 3286 jumper 1-3

Card PN 8523248 EC718946 for 3286 jumper 1-3

Card PN 8526969 EC741250 for 3286 jumper 1-3

The counter and compare card location H2 3284 and 3286 Models 1 and 2 should be jumpered as follows:

3284 and 3286 Model 1      jumper 2-3

3284 and 3286 Model 2      jumper 1-2

The card plugged in the Z2 position in the 3284 Mod 1 and 3286 Mod 1 printers has pre-wired jumpers on it. This card is used in Mod 1 printers only and does not require any additional jumpers.

## Transducer-To-Emitter Wheel Clearance

Before powering on a 3284 or 3286 printer, the transducer-to-emitter wheel clearance must be checked. Manually move the print head back and forth and listen for the sound of the transducers rubbing on the emitter wheel. If the transducers are damaged in any way, they should be replaced. Damaged transducers may cause intermittent erratic printer operation. The transducers should be adjusted according to the transducer adjustment procedure in the MLTG.

## Preferred Alternative Transducer Adjustment

Figure 6-13 gives the complete procedure for the preferred alternative adjustments of the transducer.

**Preferred Alternative Transducer Adjustment – Complete Procedure**

This complete procedure can be used whenever a transducer problem is encountered, and is offered as an alternative to separate procedures, 6.5.2, 6.5.3, and 6.5.5, found in Section 6 of the MLTG. An oscilloscope is required to perform this procedure.

The following transducer adjustment can be made easier on non-VFIC machines. Add a jumper to F2U02 to F2U10 (mod 1 & 2) or D2J06 to D2J13 (mod 3) for a continuous print pattern in offline mode.

This loop print will work on print patterns 1 and 2, and on the print buffer.

It can be useful for scoping, line feed problems, or checking for intermittent problems.

**A. Emitters and Transducers Adjustments**

*Note:* Later production version printers use different transducers and emitter wheel assemblies. The later version printers can be identified by the increased width of the emitter wheel teeth [0.125 in. (3,178 mm) versus 0.062 in. (1,588 mm) on the earlier version], and the part number stamped on the new transducer has seven digits versus six digits stamped on the earlier transducer. Clearances for the earlier version are given in steps 3 and 4, and for the later version in steps 5 and 6.

**Objective:** To align the emitter wheels with transducer tips, and to obtain the proper air gap on all transducers.

**Adjustment**

1. Remove dc power (see 6.4.2 of MLTG). Remove emitter cover (2 screws). Loosen the emitter wheel screws **A**, and position the assembly so that the emitter wheels align with the transducer tips. Tighten the screws.

*Note:* The wheel may not be centered under the transducer; however, the alignment should be the same on both wheels.

2. Loosen the transducer block clamping screws **B**, and adjust the eccentrics to position each transducer block in the center of the mounting screw slots. MAINTAIN DOWNWARD PRESSURE ON THE TRANSDUCER BLOCK, AND TIGHTEN THE SCREWS.
3. Loosen the transducer clamp screws **C**, and insert a 0.002-in. (0,06-mm) brass feeler gauge (PN 2200006) between the transducer tip and the tooth of the emitter wheel. MAINTAIN DOWNWARD PRESSURE ON THE TRANSDUCER, AND TIGHTEN THE SCREWS.
4. Check for 0.001-in. (0,03-mm) clearance by inserting the 0.001-in. brass feeler gauge (PN 2525953) between the transducer tips and the emitter wheel. When the emitter wheel is rotated, there should not be any drag on the gauge.

*Note:* Check several points on wheel with gauge to prevent possible damage to the emitters and transducers when power is turned on.

5. Loosen the transducer clamp screws **C**, and insert a 0.003-in. (0,08-mm) brass feeler gauge (PN 1863715) between the transducer tip and the tooth of the emitter wheel. MAINTAIN DOWNWARD PRESSURE ON THE TRANSDUCER, AND TIGHTEN THE SCREWS.
6. Check for 0.002-in. (0,05-mm) clearance by inserting the 0.002-in. brass feeler gauge (PN 2200006) between the transducer tips and the emitter wheel. When the emitter wheel is rotated, there should not be any drag on the gauge. Scope on A1 board to check the output of the transducers (step 7).

*Note:* Check several points on the emitter wheel with gauge to prevent possible damage to the emitter wheel and transducers when power is turned on.

7. With an oscilloscope, check both feedback transducers and print-right transducer for minimum output of 750 millivolts. (Typical output is about 2 volts.) See waveshape **E**. If output does not meet requirements recheck air gap between emitter wheel and transducers (steps 3 and 4, or steps 5 and 6).

*Note:* Check waveshape on circuit board locations A1A2B10, A1A2B04, and A1A2B07 as shown in **D**. Use ground location A1A2D08.

*Note:* To ensure correct wiring of transducers, use an ohmmeter to check for continuity between the following points:

- D**
- TB3H (brown wire) to A1A2B10 (Print-Right Transducer)
  - TB3G (black wire) to A1A2D08
  - TB3E (brown wire) to A1A2B04 (Forward Feedback Transducer)
  - TB3F (black wire) to A1A2D08
  - TB3C (brown wire) to A1A2B07 (Reverse Feedback Transducer)
  - TB3D (black wire) to A1A2D08

- B. Proceed to procedure B, Stepper-Motor Speed Adjustments.

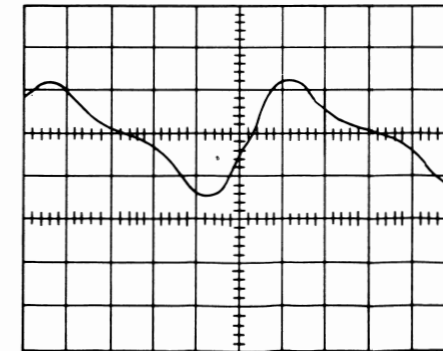
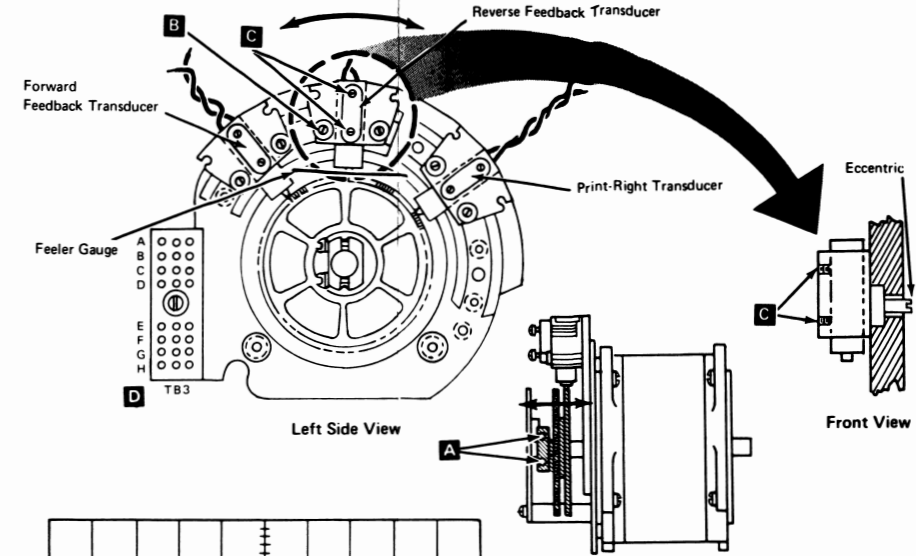

**E** Typical Transducer Output at TB3

One Cycle: 2.0 ms (3284)  
 1.2 ms (3286)  
 Volts/Division: 1V  
 Mode Channel: .1  
 Sync: Internal Coupling DC, Slope Plus  
 Source: Internal Channel 1 only.

*Note:* The leading edge of the waveshape should have a shorter rise time than the trailing edge. If not, the transducer is either wired backward or defective.

Figure 6-13 (Part 1 of 3). 3284/3286 Transducer-Adjustment Procedure

**B. Stepper-Motor Speed Adjustments**

**CAUTION**

- Do not make transducer adjustments while printing. Print wire damage may result.
- The speed of the printer will vary greatly with only a small change in the position of the adjusting eccentric.
- Stepper-motor advance pulses that vary more than 150 usec may be due to binds in leadscrew, excessive drag on ribbon, stepper-motor circuit failures, or other failures. Eliminate binds before making motor-speed adjustments (6.5.1 of MLTG).
- Critical or difficult-to-adjust stepper-motor speed may be a result of:
  - Defective printer PC board
  - Defective emitter amplifier card (01A-A1B2)
  - Defective stepper motor assembly
  - Defective emitters
- This adjustment must be made with print carrier returning at low speed.
- Adjust forward transducer with the head moving to the right.
- Adjust reverse transducer with the head moving to the left.

**Forward Speed Adjustment:**

- a. Set CE switch to PRINT PATTERN position.
  - b. Install the ribbon cassette.
  - c. To make carriage move without printing, perform power-on reset operation.
2. Sync on and look at the output of the forward transducer at point A1B2-J12.
  3. Loosen two mounting screws on forward feedback transducer mounting plate, and adjust eccentric for proper trace **A**. Press mounting plate toward emitter wheel, and tighten mounting screws.

**Reverse Speed Check and Adjustment:**

**Note:** Disable high-speed return by jumpering the slowdown margin switch (A1G2-B06 to G2-D08 Models 1 and 2, A1E2-B06 to E2-D08 Model 3).

1. Sync on and look at the output of the reverse transducer at point A1B2-D12.
2. Loosen two mounting screws on the reverse feedback transducer mounting plate, and adjust eccentric to obtain proper trace **A** as the carriage moves in a reverse direction. Press mounting plate toward emitter wheel, and tighten mounting screws.
3. Remove the jumper used to disable high-speed return, and check that the carrier returns at high speed.
4. Proceed to procedure C, Print Carrier and Print Emitter Adjustment.

**A** Typical Speed Adjustment Trace

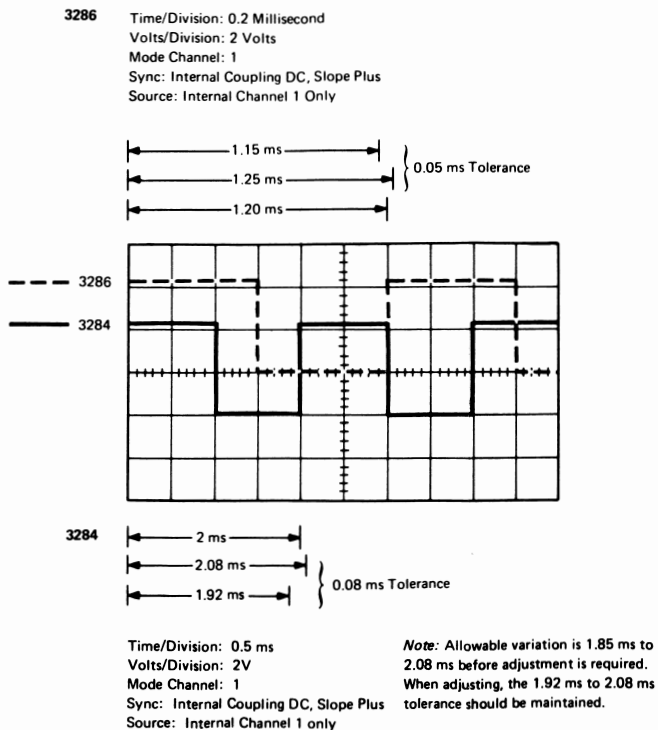

Figure 6-13 (Part 2 of 3). 3284/3286 Transducer-Adjustment Procedure

### C. Print Carrier and Print Emitter Adjustment

#### Objectives:

- To position the left end of the carrier support shaft flush with the side casting and then to align the edge of the print carrier with the milled ring on the carrier support shaft.
- To align the middle scribed line on the print emitter wheel to the print-right transducer tip.
- To position the print position pointer to indicate print position 1.

**Note:** If the following adjustment is required, recheck the stepper-motor speed adjustments (procedure B).

**Service Check:** Return the carrier to print position 1 and check that:

- Left edge of carrier aligns with milled ring **A** on left end of carrier support shaft.
- Print-right transducer tip **D** aligns to center scribed line on print emitter wheel.
- Print position indicator indicates print position 1 **G**.

If the carrier is off the scribed line **A** one print position (0.100 in.) (2.54 mm), adjust the left margin switch. If the carrier is off the scribed line less than one print position (0.100 in.), make the following adjustment.

#### Adjustment:

- Place machine in offline status.
- Loosen the setscrew and position the left end of the carrier support shaft flush with the side casting **B**. Tighten the setscrew (may be on right side of carrier support shaft).
- Loosen the 2 coupling screws **C** to disconnect the leadscrew from the stepper motor.
- Turn power *off*, then *on*, to perform a POR. The stepper motor will start. Move the head manually to the right margin. The stepper motor will reverse. Now move the head back to the left margin. The stepper motor will stop in the detented position (**A** **B**) if the margin switch works correctly.
- If not already done, remove the emitter cover (2 screws).

**Note:** Minor misalignment (within the limits of the eccentric) can be corrected by positioning the print-right transducer in relation to the print emitter wheel.

- Loosen the two print-right transducer mounting block screws **E** and, using the eccentric adjusting screw, position the mounting block to center the screws. Maintain downward pressure on the transducer block, and tighten the screws.
- Turn the leadscrew until the left edge of the print carrier aligns with the milled ring **A** on the carrier support shaft. Ensure that the coupling flange is against the bearing, and tighten the coupling screws.
- Loosen the emitter wheel clamp screws **F**, and align the middle scribed line **D** with the print-right transducer tip. Tighten the screws. Ensure that the wheel is centered under all transducers.
- Loosen the two print-position pointer screws **G**, move the pointer left or right to indicate print position 1, and tighten the screws.

**Note:** The following adjustment is made after the 3284/3286 printer is running and up to its proper speed.

- Jumper pin A1G2B06 to A1G2D08 Models 1 and 2, A1E2B06 to A1E2D08 Model 3 (-Slow Down Switch).
- Connect pin A1J3B02 Models 1 and 2, A1C3B02 Model 3, to the "External Trigger Input" plug of the scope.
- Sync the scope on a negative-going signal.
- Look at the "+Motor is Equal to Zero" signal at pin A1G3D05 Models 1 and 2, A1E3D05 Model 3, with scope channel number 1.
- Look at the "+Hammer Drive" pulses at pin A1J5B07 Models 1 and 2, A1C5B07 Model 3, with scope channel number 2.
- Loosen the two mounting screws on the Print Right Transducer, and adjust the eccentric so that the third "Hammer Drive" pulse is centered between the first two "Motor Equal to Zero" pulses **H**.
- Replace the emitter cover (2 screws).
- Check margin switch adjustment (6.5.4 in MLTG).

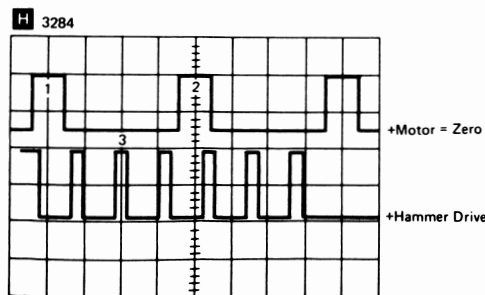
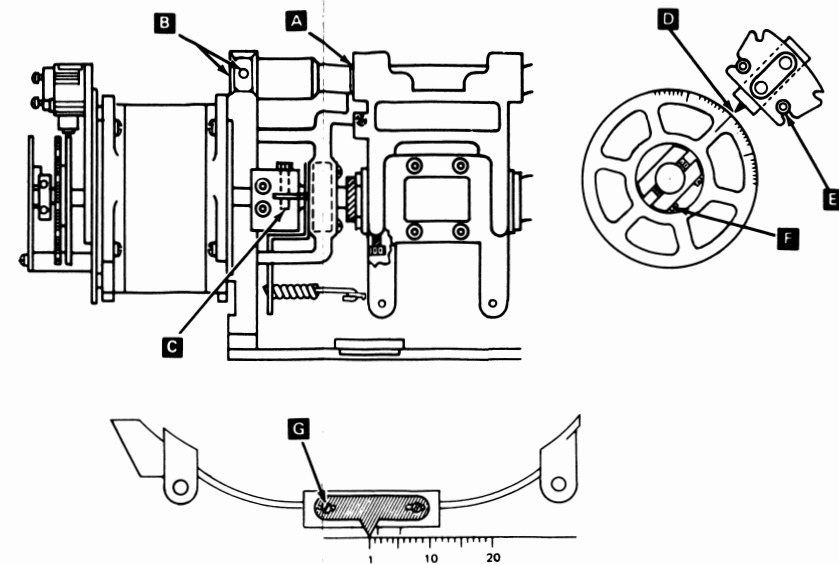

Time/Division: 2.0 ms (3284)  
Volts/Division: 2V  
Mode Channel: Alternate  
Sync: External Trigger  
Negative Slope

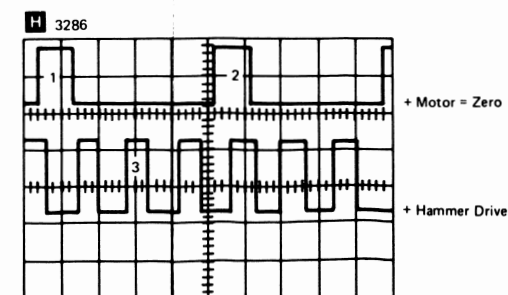

Time/Division: 1.0 ms  
Volts/Division: 2V  
Mode Channel: Alternate  
Sync: External Trigger, Negative Slope

Figure 6-13 (Part 3 of 3). 3284/3286 Transducer-Adjustment Procedure

### Improved Glare Shield

An improved glare shield is available from Mechanicsburg. If the shield fits improperly and/or slides forward temporarily binding the top cover glare shield PN 2495731, PR Code 34 from Mechanicsburg. Use service record ECA 012 for 3284 & 3286 Mod 1 & 2, or ECA 011 for 3284 & 3286 Mod 2.

### Cover Interlock

Do not permanently disable the cover interlock switch. If the switch is disabled, the user will be exposed to a potential safety hazard. Use the following procedure to correctly adjust the cover interlock switch.

Depending on how the cover interlock switch was originally assembled, it is actuated by the north or south pole of the operating magnet (horseshoe magnet) or both. The correct relationship between the operating magnet and the bypass magnet (part of the assembly) can be established by observing which pole of the operating magnet repels the bypass magnet. The pole of the operating magnet that repels the bypass magnet should be positioned so that it approaches the cover interlock switch when the cover is being closed and should not pass beyond the switch when the cover is fully closed.

Before making any adjustments to the operating magnet mounting bracket, ensure that the inside plastic cover PN 2495628 is fully seated in the screw slots. Verify the correct vertical location of the switch.

When the above relationships are established, adjust the operating magnet as follows:

1. For the front-to-rear adjustment, provide approximately 0.060 in. (1.52 mm) clearance between the inside plastic cover and the front of the magnet mounting bracket PN 1804717 forward until the magnet just contacts the inside plastic cover as the top cover is being closed. Now, reposition the bracket toward the magnet until there is approximately 0.060 in. (1.52 mm) to obtain the required clearance.
2. For the left-to-right adjustment, provide approximately 0.120 in. (3.04 mm) clearance between the inside plastic cover and the left edge of the magnet by moving the magnet PN 2495691 to the left until it just contacts the inside plastic cover as the cover is being closed. If the magnet contacts the plastic cover, then reposition the magnet to the right approximately 0.120 in. (3.04 mm).

*Note:* Optional EC 141990 provides for adjustment of the cover interlock switch operating magnet in the vertical direction, which increases the reliability of the cover interlock adjustment. For machines without this adjustment capability, order EC 141990 (ECA 019).

3. For the vertical adjustment, adjust the magnet plate PN 1804718 to the top of the bottom of the operating magnet 0.060 in. (1.52 mm) above the bottom of the interlock switch. This relationship can be checked by removing the cover interlock switch and observing through the left platen knob hole (with the cover fully closed).

*Note:* The adjustment can be checked as follows (the Ready lamp can be used as a reference point):

- a. Power off the printer.
- b. Move the cover to a position that is from 0.25 in. (6.35 mm) to 0.50 in. (12.7 mm) from the fully closed position. This distance should be measured or checked with a CE meter point directly in front of the operating magnet. Check for zero ohms (0 Ω) on the CE meter) between the following points:
  - 3284/86 Models 1 and 2 – A1F2S04 and any D08 pin
  - 3284/86 Model 3 – A1D2G06 and any D08 pin
- c. Raise the top cover and activate the CE bypass by attracting the CE bypass magnet to the bypass position. Verify that the CE bypass magnet is repelled by the interlock operating magnet as the cover is closed.

Covers should not be switched between machines without readjustment of the cover interlock assembly. To assist in the evaluation of the cover interlock performance, record the time spent diagnosing cover interlock problems as major code 000.

## Data Check

Sense and status of DATA CHECK with UNIT SPECIFIED and/or an X printed in the text is usually caused by a defective buffer card, socket B4, B5, C4, C5. If a character is distorted or missing without a DATA CHECK and UNIT SPECIFIED and/or an X in the printout, the character generator card in J2 is probably defective. If replacement of these cards does not resolve your problem, refer to the 3284/3286 MLTG.

## Crash Stopping and/or Equipment Check

1. Crash stops at the left margin may be caused by improperly assembled left margin switches. Two reed switches are required for *slow* and one reed switch is required for *stop*. It is possible that the reed switches were installed in the wrong slots in the switch assembly. The slot closest to the wires attached to the switch assembly should be empty and each of the other three slots should contain a reed switch. These reed switches are not installed in the correct slots within the margin switch assembly, order a new assembly PN 2495539. Also check the wiring to the switches.
2. The above symptoms can also be caused by loose reeds in the left or right margin assemblies (2495539 and 2495540).
3. Equipment checks, carrier slamming into the left margin, or carrier not reaching the left margin may be caused by the incorrect printer assembly or incorrect PC board being installed on a 3284 or 3286. The printer assembly can be identified by reading the PN stamped in the base of the mechanical printer assembly. The PC board can be identified by removing it from the printer and reading the PN etched in the board.

The correct PNs for the respective machine types are in the following chart:

	<u>3284</u>	<u>3286</u>
Printer assembly	PN 2642460	PN 2642490
PC board assembly	PN 2632611 or PN 2642553	PN 2495781 or PN 2642552
PC board etched #	PN 0373569	PN 0373568

Refer to logic page ZZ101.

If you have the incorrect PC board, order a new PC board assembly.

## +5V Power Supply Failure

Loss of +5V may be due to loose diodes. Before replacing the power supply, PN 2582950, or PC board PN 2582963, make sure CR3 and CR4 mounting nuts are tight. CR3 and CR4 are located at the top of the PC board and are the only diodes mounted with hex nuts.

## Power Supply Service Information

Intermittent and difficult to diagnose problems in 3271, 3272, 3284, and 3286 machines may be caused by excessive ripple on the power supply voltages. The ripple may be caused by loose capacitor mounting screws in the power supply. On your next service call, these screws should be checked as follows:

1. If screws are loose, tighten them. (Refer to ECA 037.)
2. If screws appear to be tight, loosen the screws one full turn and retighten them.

Ripple can be checked using an oscilloscope. Maximum allowable ripple is as specified in Figure 1-1 (Section 1). MLTG Page B-2 shows DC power distribution to the logic board and should be used when checking power supply voltages.

If you are replacing the 3284/3286 power supply printed circuit board because of burned land patterns at the AC input connector pins 3 and 4 (24 Vac), a permanent fix can be made by cutting transformer leads 12 and 14 at the connector and soldering directly to diodes CR1 and CR2 on the board. Securely wrap the transformer lead around the anode lead of the corresponding diode and solder. See drawings 7.4 and 7.7 in the *3284/3286 Troubleshooting Guide* (SY27-2315).

When replacing the LVPS in 3271, 3272, 3284, and 3286, tighten the two upper mounting screws in the machine frame. Failure to do this can result in personal injury if the power supply drops after removal of the front cover.

## Equipment Checks

The following is a checklist for intermittent and difficult to diagnose EQUIPMENT CHECKS:

1. Forms motion switch — defective or maladjusted.
2. Cover interlock switch — defective or maladjusted.
3. End of forms switch — defective or maladjusted.
4. Print emitter transducer — defective or maladjusted.

*Note:* All emitters should have a minimum of .001 clearance to the highest point on the emitter wheel.

5. Power supply capacitors loose or making poor contact.
6. Check index pawl for lubrication or binds.
7. Check index link for adjustment.
8. Transducer cable shields, part of cable PN 2570242, may short to ground and cause equipment checks. This cable runs from the logic gate socket A2 to the 15-position connector near the cable feed through hole at the top of the power supply. The shields for the transducer cables are exposed at the 15-position connector end of the cable, and may short to ground where the cable clamp holds the cable to the frame. These shields should be protected with electrical tape.

## Index Pawl Carrier Return Spring Breakage

On some early "A" frame printers, the index pawl carrier return spring, PN 1175330, (refer to Parts Catalog S126-0006-2, fig. 7, item 20) was subject to premature breakage due to interference with the "A" frame front leg. The index pawl carrier return spring should be anchored to the line selector hub, and the open side of the hook should be up. This should be done as part of your next service call and the time should be recorded as Service Code 08.

## Indexing on Power-On Reset

If the printer indexes for approximately 15 seconds after a power-on reset, the machine should be checked for the following EC:

Model	ECA	EC Number	New Card PN	Location
1 or 2	009	718977	8523248 or 8526969	01A-A1G2
3	005	718946	8523248 or 8526969	01A-A1E2

If the EC is not installed, order the EC which is applicable to your machine. If, after installation of the EC, indexing still occurs on POR, replace the B2 card, PN 8526065.

## Safety – 3284/3286 Top Cover Window

### DANGER

A potential safety hazard from sharp edges exists if the top cover window is broken. The edges of the broken window (PN 2495724 or PN 2642424) are very sharp. The CE should respond immediately to any service call about a broken window and be very cautious in handling the pieces of the window.

## Maintenance Monitor

Printers manufactured after May 1974 do not have a maintenance monitor. The carbide print head was introduced into the production line in May 1974 and since the carbide print wires SHOULD NOT be stoned, the maintenance monitor was removed. Carbide print heads can be identified by black paint in the heads of the allen screws of the print magnet assemblies. Preventive maintenance on machines without a maintenance monitor should be done based upon the monthly frequency in the PM routine chart in the MLTG.

## Printer PC Board and MST Card Damaged

### CAUTION

The loss of cooling due to a broken motor drive belt (PN 1804937) or a broken fan drive belt (PN 2495683) could cause damage to the PC board or the MST cards in the printer assembly. Mandatory ECA034 must be installed to eliminate this exposure.

## Corrections and Additions to 3284/3286 Parts Catalog S126-0006-4

Fig.	Item	Description of Correction
2	18	PN 2495724 has grooves for mounting screws.
2	18	PN 2642424 has studs in place of grooves for mounting.
2	37	PN 2642437 is obsoleted and replaced by PN 2642431.
4	11	PN 5861753 desc should be CARD ASM-7 wire printer.
4	12	PN 2642552 desc should be BOARD ASM, PC 3286.
4	12	PN 2642553 desc should be BOARD ASM, PC 3284.
4	22A	PN 0736535 desc should be SWITCH ASM, MICRO.
4	22A	PN 2495769 desc should be SWITCH, REED.
4	39	PN 2495679 desc should be RACK, RIBBON DRIVE.
4	57	PN 2495630 desc should include TUNGSTEN.
4	57	PN 2495585 desc should include TUNGSTEN.
*4	57	PN 1804867 PRINT HEAD ASM, 7 POSITION CARBIDE.
*4	57	PN 1804868 PRINT HEAD ASM, 8 POSITION CARBIDE.
4	59A	PN 2495578 NP desc should include TUNGSTEN, BRONZE MAGNET.
*4	59A	PN 2640788 order in place of PN 2495578.
*4	59A	PN 1805671 magnet and hammer asm-end POS, CARBIDE, BRONZE MAGNET.
4	59B	PN 2495586 NP desc should include TUNGSTEN, DULL GRAY MAGNET.
*4	59B	PN 2640787 order in place of PN 2495586.
*4	59B	PN 1805672 MAGNET AND HAMMER ASM, MIDDLE POSITION, CARBIDE, DULL GRAY MAGNET.

\*=Add

*Note:* Do not mix tungsten and carbide components on the same print head asm. Carbide asm can be identified by black paint in the head print magnet asm allen screws. Tungsten asm are identified by red in mag asm screws for Domestic machines and white paint on World Trade machines.

Fig.	Item	Description of Correction
4	72	PN 2495634 should be PN 2495625.
5	29	PN 1117883 clevis asm — adjustable 2 per machine.
6	3	PN 1128527 desc should include 27 teeth.
6	3	PN 1135192 desc should include 36 teeth.
9	11	PN 2642563 includes a 4 x 9 timing disc asm.
9	11	PN 2642565 includes a 4 x 7 timing disc asm.
10	10	PN 2640791 desc should be ROLL, BELT RETAINING, 3284.
*10	10	PN 2632600 ROLL, BELT RETAINING, 3286.
10	16	PN 2640792 desc should be PULLEY ASM, 3284.
*10	16	PN 2632586 PULLEY ASM, 3286.
13	11	PN 5214955 is obsoleted and replaced by PN 846371.
13	21	PN 2481207 and PN 375435 are interchangeable — delete the LOCAL and REMOTE from their description.

4-22A, and note in Figure 5, detail B—Switch is not part of cable asm. 2495749.

Fig.	Item	Description of Correction
5	85	PN 1863930 should be 1863630
13	41A	PN 5214456 fuse 6A
13	41B	PN 5267682 label fuse 4
13	41C	PN 512137 fuse 5A slo blow
13	41D	PN 5267687 label fuse 5
13	41E	PN 5214925 fuse holder
13	41F	PN 5267675 bracket
13	41G	PN 10170 screw
13	41H	PN 5214437 wire nut
14	11	PN 2495749 Item 19 should be deleted from description.
15	39A	Should be slide switch, CE 3284/86 Ribbon Cartridge PN 1136970.

## Indexing Problems

On installation and prior to making adjustment to the indexing mechanism, be sure the entire mechanism is lubricated; refer par. 8.5 in the 3284 and 3286 MLTG. In addition to those items in par. 8.5, the platen bushings should also be lubricated. It may be necessary to remove the bushings so the shaft may be cleaned and lubricated with IBM No. 23 grease or equivalent before reinstalling the bushings. If adjustment is necessary after lubrication, refer to MLTG par. 6.7.12. If the indexing mechanism is maladjusted and the index pawl contacts the overthrow stop, you may break the index link. The improved index link is PN 1863642 and clevis (2 req) PN 1117883.

The set screws in the platen variable guide may loosen due to vibration. This causes indexing failures and should be corrected as part of your next 01 or 08 call.

Refer to Fig. 6, items 9 and 10, in the Parts Catalog, S126-0002-2:

1. Remove the set screws PN 1175106 from the platen variable guide PN 1203742.
2. Put a drop of IBM cleaner (PN 450608 — 6 oz. can) or equivalent into the set screw holes and allow the cleaner to dry.
3. Put a drop of Loctite\* sealant E PN 605960 or equivalent into the set screw holes.
4. Tighten the set screws firmly.

There are two ECs available to correct a problem of a missing index during a multi-indexing operation. These are optional ECs and should be ordered if required.

Model 1 & 2	ECA 005	EC 718555
Model 3	ECA 004	EC 717958

\*Trademark of Loctite Corp.

## VFIC RPQ Service Information

### General Service Information

The vertical forms index control (VFIC) RPQ, when used in conjunction with special preprinted forms and a special software instruction, provides for automatic vertical positioning of paper forms to specific line locations designated by the customer. It is necessary for the operator to align the forms (via the platen vernier) to position the first line of print any time forms are inserted in the printer. Thereafter, alignment is maintained via VFIC.

Reliable operation of VFIC is very dependent upon properly designed forms. This and other special considerations, such as limitations and programming information, are covered in the RPQ's *Custom Feature Description Manual*, GA27-2753-3.

The VFIC RPQ consists of a photosensor device and associated circuitry. All of the unique logic is located on one card (K4 card in models 1 & 2 or F4 card in model 3). The photosensor device consists of an infra-red light emitting diode and a photo transistor. The sensor is strategically positioned so the index mark will interrupt the light beam as the mark passes the sensor and thereby positions the form for the next line of print.

A VFIC operation is initiated by the decode of a forms feed character (HEX 'OC') in the data stream. This starts paper indexing which continues until it is halted by recognition of the index mark by the photosensor. If no index mark is detected within 128 indexes (192 indexes, if ECA 035 installed), the printer ceases to index any further, and a VFIC error condition is automatically signalled to the printer's host system. At the host system, the error condition is manifested by the following sense (3272 unit) or sense and status (3271, 3275 units) information:

If control unit is a 3272 unit:

- Intervention Required (Bit 1)
- Equipment Check (Bit 3)
- Unit Specify (Bit 5)

If control unit is a 3271 unit:

- Unit Specify (Byte 0, Bit 5)
- Device End (Byte 0, Bit 6)
- Intervention Required (Byte 1, Bit 3)
- Equipment Check (Byte 1, Bit 4)

If control unit is a 3275 unit:

- Device End (Byte 0, Bit 6)
- Intervention Required (Byte 1, Bit 3)
- Equipment Check (Byte 1, Bit 4)

A power-on reset is required to reset these error indications, unless ECA 035 is installed, in which case the VFIC reset switch should be used.

### Forms Considerations

The forms for the VFIC RPQ must be designed to the specs called out in form GA27-2753 for reliable operation.

1. Location of the mark. Specs in form GA27-2753, Fig. 1.
2. Print contrast signal of the mark minimum spec 0.8. Black ink is recommended for the mark to meet this spec.
3. VFIC margin must be free of all marks other than VFIC mark.
4. Thickness of the form maximum of 0.014 in. (0.356 mm).

5. Fastening methods:

- a. Temporary (crimps) or flexible fastening methods are recommended.
- b. Forms having full width processed carbon may cause problems if the carbon extends into the VFIC margin. The carbon may affect the PCS readings or it may show through fastener holes or perforation holes. Ideally, the carbon should not extend into the VFIC margin.
- c. Glued forms cause feeding problems because of the small diameter of the platen and should be avoided.

**VFIC RPQ Adjustment Hints**

All VFIC adjustments are covered in the following MLTGs:

- |                           |           |
|---------------------------|-----------|
| 3284/86 – 1 & 2 VFIC MLTG | SY27-2341 |
| 3284/86-3 VFIC MLTG       | SY27-2342 |

There are three positioning adjustments for the VFIC sensor which should be made with the alignment tool, PN 5244758 (shipped with the printer). When making the front/back adjustment (par. 6.10.9 of MLTG), it is important that the sensor be adjusted so both diodes in the assembly are aligned to the horizontal line in the "H" on the alignment tool, PN 5244758. The VFIC sensitivity control should then be adjusted per the MLTG.

If operation is not reliable after these adjustments have been made, it may be due to forms. As a temporary measure, these adjustments may be optimized to the customer's form. With a sharp knife, cut an index mark out of the customer's form and then use this form as a template for making the sensor head positioning adjustments.

If customer forms are not within the specifications of GA24-3488, notify the customer of his possible continued exposure to forms movement problems.

*Note:* General information from the GA24-3488 manual can be found under the heading "Forms Design Consideration and Specifications" in Section 8 of this handbook.

**VFIC RPQ Failure Analysis**

For VFIC type failures, refer to ECAs 035, 041, 044, and 045, if applicable.

Skipping extra pages (failure to recognize the index mark):

1. Out of specification forms – specifications for location of the mark, size of the mark, and Print Contrast Signal (PCS) of the mark are given in the *Custom Feature Description Manual*, GA27-2753.
2. Defective or maladjusted photosensor (PN 5244707) – there are three positioning adjustments. Refer to the VFIC MLTG for correct procedures.
3. Defective VFIC card  
3284/3286 Models 1 & 2 location K4  
3284/3286 Model 3 location F4
4. Defective or maladjusted forms motion switch.
5. Slow movement of the index mark past the sensor. The sensor is self-biasing, so if the forms slow down while the mark passes the sensor, the sensor can self-bias faster than the mark can affect the sensor. Items to be considered that could cause the form to slow down are:
  - a. Index mechanism and paper path adjustments
  - b. Forms thickness
  - c. Forms weight
  - d. Forms output should not be allowed to stack on top of the input supply
6. Adjustment of VFIC sensitivity control.

Stopping at the wrong place on the form:

1. The VFIC margin must be free of printed information. Targets, bleed lines, hard fasteners, crimp fasteners, or spot carbons may be detected as index marks by the photosensor.
2. Heavy, stiff or glued forms may make the paperweight bounce which would be recognized as an index mark.
3. If the carbon extends into the VFIC margin, the carbon may show through the horizontal perforations.
4. Defective or maladjusted photosensor PN 5244707.
5. Defective VFIC logic card  
3284/3286 Models 1 & 2 location K4  
3284/3286 Model 3 location F4
6. Adjustment of VFIC sensitivity control.

### Variable Margin RPQ EB3995

Extra indexes may occur on a machine with variable margin stop RPQ EB3995 if the customer's program is using new line codes, and the right margin switch is set too far to the left. The right-hand margin switch should be positioned far enough to the right so it will not 'make' prior to the new line code.

### Safety – DC Power Cable

The dc voltage distribution cable should be inspected for insulation breakdown.

Cable assembly PN 2570243 supplies dc voltages to the back panel of the logic gate. The individual wires of this cable are held against the back of the board by black plastic straps pressed onto the pins of the logic board. On your next 01 or 08 call, please inspect these cable wires to see that the insulation is not being damaged by being pressed against the back panel pins. Relocate the wires as necessary to eliminate pressure between the wires and logic pins.

### Too Many Jumper Pins on Card PN 8523248

Some of the motor control cards PN 8523248 were manufactured with four jumper pins instead of three. If you have any of these cards, they should be altered as follows:

Hold the card with the shroud down and the component side facing you, then cut off the second pin from the top.

Card Location:

Models 1 and 2	A1G2
Model 3	A1E2

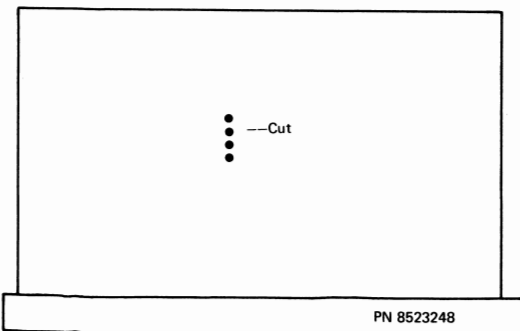

## 5's and/or 9's Printing for NL or EM Orders

The printing format is determined by the write control character (WCC) on a write command or the copy control character (CCC) on a copy command (3271 only).

In formatted mode, the line length is specified in the WCC or CCC as 40, 64, or 80 characters per line and NL or EM orders are *not* executed. Instead, they are printed as graphics "5" and "9", respectively.

In unformatted mode, an NL order in the buffer causes the printer to perform a new line function, and an EM order terminates the printing operation. In unformatted mode, there are no graphic characters printed for the NL or EM characters.

If a printer prints "5" or "9" when it is known to be in unformatted mode, suspect the following components:

### 3284/3286 Models 1 & 2

ONLINE/OFFLINE SWITCH (INTERMITTENT)

Printer A1F2 card

Printer A1H2 card

Printer A1J2 card

### 3284/86 Model 3

ONLINE/OFFLINE SWITCH (INTERMITTENT)

Printer A1C2 card

Printer A1D2 card

3275 01A-A1L2 card

## ALD Version Level Feature Identification

The version level of ALD pages is an indication of what features and RPQs are covered by that page. The version level is located adjacent to or directly below the page number, e.g.,

Page	Ver	EC Lev	or	BP101
BP101	000	717474		000

The following is a cross-reference of ALD version levels to feature or RPQ names:

Version	Feature or RPQ
000	Base
001	Katakana
002	Dual Case RPQ 8K0366
007	Vertical Forms Index Control (VFIC) RPQ EB4324
A17	VFIC and Katakana
A27	VFIC and Dual Case

## Stepper Motor and Speed Adjustment Service Hints

Stepper motor resistance check.

From	To	Color Code	Resistance
EC4-M	EC4-H	Black to Red	3.2 ohms + or - 5%
EC4-L	EC4-F	White to Blue	3.2 ohms + or - 5%
EC4-B	EC4-H	Red/white to Red	6.4 ohms + or - 5%
EC4-D	EC4-F	Blue/white to Blue	6.4 ohms + or - 5%

Critical or difficult to adjust stepper motor speed may be a result of:

- Defective printer PC board
- Defective emitter amplifier card (01A-A1B2)
- Defective emitters
- Defective stepper motor assembly

## MLTG Updates

The following MLTG updates have mistakes which you should correct in your copy.

Technical Newsletter (TNL) SN31-0051 for 3284-3 MLTG SY27-2316-2 should be corrected as follows:

1. Page D-2 A, typical speed adjustment trace is incorrect, the correct example is on page 6-28.
2. Adjustment step 7 – jumper pin, A1E2B07 should be pin A1E2B06.

Technical Newsletter (TNL) SN31-0052 for 3286-3 MLTG SY27-2317-2 should be corrected as follows:

1. Page 3-1 paragraph 3.2.5 – The word FAST in the last sentence should be FACT.
2. Page 6-28 – Time/division under the scope waveform should read 0.2MS instead of 0.5MS.
3. Page D-2 – Time/division under the scope waveform should read 0.2MS instead of 0.5MS.
4. Page D-3 – In adjustment step 7, jumper pin A1E2B07 should be pin A1E2B06.

New MLTG for 3284/86 models 1 & 2 SY27-2315-3 should be corrected as follows:

1. Page 2-1 – The part number for the forms guide will be changed when a new guide is released.
2. Page 5-9 – Test point G/11 should read: “–RIGHT MARGIN GATE”.
3. Page 5-36 – The time/division shown under the scope trace should read as follows: 0.5MS for 3284 or 0.2MS for 3286.
4. Page 6-28 – The time for 3284 under the scope trace should be 1.92MS instead of 1.93MS.
5. Page D-1 – The time/division for the scope trace should read as follows: 0.5MS for 3284 or 0.2MS for 3286.

## Ribbon Jamming or Feeding Problems

The ribbon cassette latching lever (PN 2632671) should be formed to correct jamming problems which may exist with some cassettes.

Some cassettes were produced undersized, which allows too much latching clearance. This condition can be corrected by forming the cassette latch level (PN 2632671) item 4 of Figure 10 in 3284/86 Parts Catalog, S126-0006-2.

Form the cassette latch lever as follows:

1. Power the machine off.
2. Open the top hinged cover.
3. Open the cover over the carrier worm shaft.
4. Position the print head so you have access to the cassette latch lever.
5. Twist the cassette clockwise and observe the clearance between the cassette and the ear on the right side of the cassette latch lever.
6. If any clearance is observed, form the ear to the left to eliminate any clearance.
7. Return the machine to operating status and observe for proper operation.

If experiencing jams on newly installed ribbon cassettes, it could be due to improper installation. It should be emphasized to user personnel that the cardboard strip protecting the cassette entry should not be removed until after the cassette has been latched in place. When reinstalling a ribbon cassette which has been in use, ribbon slack should be kept out of the cassette entry area when latching the ribbon in place. Rotate the feed roll by hand several times to verify proper feeding before returning to operation.

An improved ribbon drive roll is available from Mechanicsburg.

## Ribbon Drive Roll

The ribbon drive roll has been redesigned to improve the ribbon drive operation. The rubber feed rolls have been replaced by a serrated urethane feed roll assembly. The new

ribbon drive shaft assembly (PN 5165590) will eliminate the need for spacer (PN 2632608) and will require a new cassette aligner (PN 2632609). The new style ribbon drive roll assembly should be installed on all 3284/3286 printers presently experiencing excessive replacement of drive roll or experiencing ribbon feed problems.

### Installation Instructions

1. Remove the cassette aligner (PN 2632609), the ribbon drive roll (PN 2632584), and the spacer (PN 2632608). Scrap locally.
2. Install new cassette aligner (PN 2632609). Mount aligner flush with shoulder on mounting plate.
3. Install new ribbon drive roll assembly (PN 5165590). Adjust collar for minimum end play without binding.

RIBBON DRIVE ROLL  
OLD STYLE  
(P/N 2632584)

\* CASSETTE ALIGNER  
(P/N 2632609)

RIBBON DRIVE ROLL  
NEW STYLE  
(P/N 5165590)

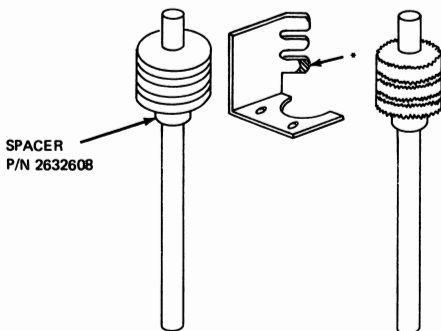

\* The cross-sectioned portion of the aligner has been removed on current level and only the current level aligner should be used with the new style drive roll.

### Variable Margin RPQ EB3995 Parts Information

Parts information for RPQ EB3995 is available on logic page ZZ202, part number 2570155, which can be ordered for addition to the logics. In lieu of this logic page, the following is a list of parts used on this RPQ:

PN 2495539	Margin switch asm, left hand – one per machine.
PN 2495540	Margin switch asm, right hand – one per machine.
PN 2495548	Spring. One per asm, 2 per machine.
PN 2495516	Detent – one per asm, 2 per machine.
PN 2495549	Cap, switch mounting – one per asm, 2 per machine.
PN 2495527	Indicator – one per asm, 2 per machine.
PN 81693	Screw, upper – 2 per asm, 4 per machine.
PN 2495677	Cable asm, one per machine.
PN 2495550	Bar, switch mounting, one per machine.

### Forms Tractor RPQ WD4031 Service Information MLTG – SY27-2356-1 Custom Feature Description Manual – GA27-2773-0

Problems with the forms tractor manifest themselves as forms-feeding problems and/or equipment checks which are a result of detection of a mechanical hang condition.

For forms-feeding problems, make the following checks and take corrective action as required.

1. Verify that the correct top cover is installed by observing the hole the platen knobs project through. On tractor machines, the lower half of that hole is larger than the top half.
2. Verify the presence of spacer PN 120437 on top cover mounting bolts directly under platen knobs. This spacer should be between the top cover and the bolt retaining clip.
3. Verify that guide PN 1804900 is mounted lower on the top cover so the forms entry is aligned with the tractor paper guide.
4. Verify presence of a small rubber pad PN 1804786 glued in the V groove in the front of the mechanical printer asm base.
  - b. Verify the presence of two rubber pads PN 1804901 glued to the rear of the mechanical printer asm base.
  - c. These three rubber pads should mate with the ribs on the inside of the top cover asm, and their purpose is to raise the top cover to provide adequate clearance from the paper feed path to the top cover.
5. Check for free movement of the tractor shafts. Binds in this area may be due to the following:
  - a. Tractor chain tension (refer to MLTG par. 4.3).
  - b. Idler gear wink (refer to MLTG par. 4.5).
  - c. Tractor shaft side frames not perpendicular to the tractor shafts – form as necessary.
  - d. Bent tractor shafts can be identified by observing the clearance from the tractor door extension to the platen while advancing the platen. If the clearance varies excessively, one or both of the tractor shafts could be bent – repair or replace.
  - e. Interference between top cover and tractor asm.
6. Check for 0.060 (1.52 mm) to 0.090 (2.28 mm) in. between the platen and lower guide of forms entrance chute.
7. Check for correct adjustment of index link (MLTG par. 4.8) and index pawl stop adjustment (par. 4.1).
8. Check for proper forms drag adjustment (MLTG par. 4.6).
9. Check tractor alignment to scribed line (MLTG par. 4.2). *Note:* Due to variation in customer forms, it may be necessary to customize this adjustment to the customer's forms.
10. Check timing of forms moving switch per base machine (MLTG par. 6.7.11).
11. Check carriage cam release adjustment. *Note:* The unlatch clearance spec is wrong in the picture; the correct unlatch clearance is 0.010 (0.25 mm) to 0.020 in. (0.508 mm) as stated in step 2 of objectives.
12. For proper horizontal print alignment, the carrier support shaft should be projected 0.060 in. (1.52 mm) to left of the side casting. Refer to step 2 of the adjustment in basic MLTG page 6-24; the shaft should project 0.060 in. (1.52 mm) to left (not flush as shown). *Note:* If VFIC RPQ EB4324 is installed on a machine with forms tractor, there is no height adjustment and all other positioning adjustments of the sensor are done with special tool PN 5244697 which is part of the ship group.
13. Remove and discard tractor door extensions PN 1804891 and PN 1804892.
14. Adjust tractor door clearance by forming the door stop tab for 0.025 in. (0.635 mm) to 0.045 in. (1.143 mm) door clearance.

Parts catalog information for the tractor RPO is in Appendix B of the MLTG, form SY27-2356. The following are additions and corrections to that appendix.

- PN 1804793 — Top cover asm, complete — order on MES from Raleigh.
- PN 1804774 — Top cover asm, painted covers only, order on MES from Raleigh.
- PN 1804786 — Rubber spacer, top cover asm, front V groove.
- PN 1804825 — Platen, 6 LPI, order on MES Raleigh.
- PN 1655203 — Platen, 8 LPI, order on MES Raleigh.
- PN 1804761 — Gear, drive for tractor, part of platen.
- PN 1804775 — Shield, safety, over gear train for tractor asm.
- PN 1804891 — Guide, extension of left tractor door.
- PN 1804892 — Guide, extension of right tractor door.
- PN 0186393 — Screw, mounting for guides PN 1804891 and PN 1804892.
- PN 0309043 — Washer, mounting for guides PN 1804891 and PN 1804892.
- PN 1804901 — Rubber spacer, top cover asm, rear, 2 glued to frame.

## Logic Boards

Prior to replacement of a logic board, the following checks should be made:

1. Check the dc voltage distribution cable hold-down straps to see that wires are not pinched.
2. Check voltage terminations to see if they are making good contact, or if they have disturbed or loosened the wire wraps on its pin or adjacent pins.

If it becomes necessary to replace a board, the following table should help in identifying the correct board and EC level to order:

### Basic Machines:

- 3284/86 Model 1 or 2, Board PN 2625202 — EC718551 (Note 1)
- 3284/86 Model 3, Board PN 2625200 — EC717488 (Note 2)

### VFIC RPO Machines:

- 3284/86 Model 1 or 2, Board PN 2609972 — EC742212 (Note 3)
- 3284/86 Model 3, Board PN 2609974 — EC742863 (Note 4)

### Notes:

1. EC 718551 was the only change to the board since first customer ship and it was an EC level change only (no board wiring).
2. EC 717488 is first customer ship EC level and there has been no board wiring ECs since.
3. EC 742212 requires a K4 card, PN 8527309 or 8528255, and EC 742212 should be ordered to get the paper work and an additional label for the machine if the EC level is upgraded by replacement of a board.
4. EC 742863 requires a F4 card, PN 8527309 or 8528255, and EC 742863 should be ordered to get the paper work and an additional label for the machine if the EC level is upgraded by replacement of a board.

## VFIC FORMS SPECIFICATIONS

### Forms Size

In general, the dimensions of forms applicable to RPO EB4324 are identical with those specified in the 3284/3286 section of the *Form Design Reference Guide for Printers*, Order No. GA24-3488. One notable exception is that the vertical perforation on the left side of the form is nominally 0.600 inch (15.240 mm) from the left-hand edge instead of 0.500 inch (12.700 mm).

### Single Part Forms — Thickness Considerations

Customers using single part forms on their VFIC machines must use a paper in the 15 to 24 pound range.

## Multipart Forms – Thickness Considerations

Customers employing multipart forms on their VFIC machines should consider the following when designing forms:

1. Use only paper in 12- to 24-pound bond range.
2. Total forms thickness should not exceed 0.014 inch (0.355 mm) maximum.
3. If spot carbon is used behind the first part, it must start to the right of the VFIC margin.

## Multipart Forms – Fastening Considerations

Multipart forms require some method of fastening to hold the carbon in place. Temporary (crimps) or flexible fastening methods are recommended.

Forms having full width processed carbon with fastenings on either or both sides may be used provided that the fastenings do not interfere with the VFIC marks on the left side of the forms. Forms having narrow carbon fastened on the right side may also be used. Glued forms cause a feeding problem in the printer because of the small diameter platen and must not be used.

*Note:* In those cases where a customer elects to have more than one index mark imprinted on a paper form (in order to effect several, but distinct, printout operations on each form) the customer should be aware that VFIC printers are not capable of distinguishing the specific operations intended, or related to each index mark. Therefore, should the occasion arise that an index mark is not sensed by the VFIC sensor head, the paper form will automatically advance, and be positioned to the next index mark of that paper form or to one of another form. This would result in a prescribed printout operation designated for a specific location on a paper form occurring in another location of that form or on some other form. Hence, operator intervention is required to reposition the paper forms whenever this condition occurs.

## Index Mark – Size and Location

The dimensions of the index mark and the location of the mark on the form are to be as indicated in Figure 6-14.

## Ink-Color/Paper-Color Combinations

Black ink is recommended for the index mark in order to meet a 0.8 minimum print contrast signal (PCS) value. However, any ink-color/paper-color combination that meets a 0.8 PCS value is acceptable. PCS is defined as follows:

$$\text{PCS} = \frac{\text{Reflectance of Paper} - \text{Reflectance of Printed Area}}{\text{Reflectance of Paper}}$$

PCS measurement is to be made with the infrared probe of an 081 Kidder Tester\*, filtered with an 87C Kodak Gelatin Filter† (or equivalent). Measurement of multipart forms must be made on the entire paper package with all parts in place, rather than on the first part alone.

\*Kidder Machinery Division, Moore Business Forms Inc., Dover, New Hampshire

†Eastman Kodak Co., Rochester, New York

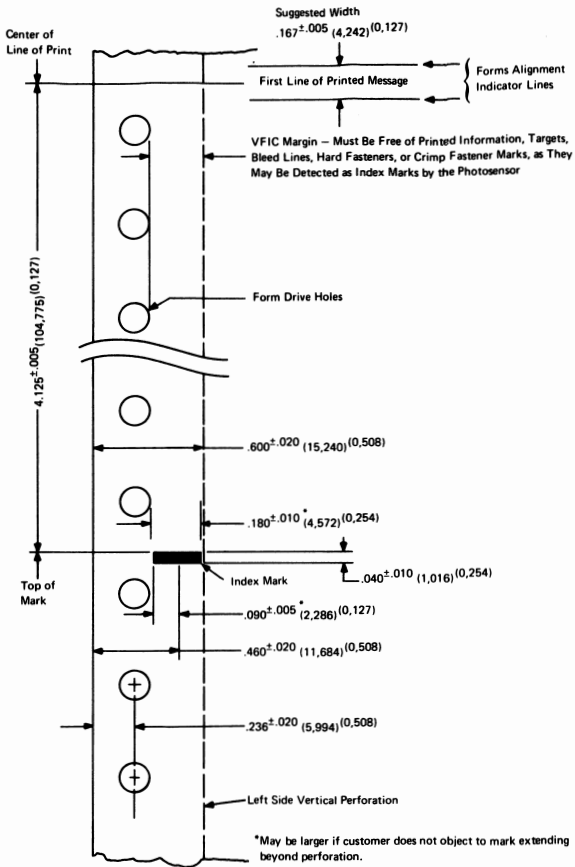

Figure 6-14. VFIC Form, Locations and Dimensions

## Section 7. 3288 Line Printer

### Contents

<b>3288 Symptom Fix List</b> . . . . .	7-3
<b>3288 Card Substitution List</b> . . . . .	7-6
Basic Unit . . . . .	7-6
Mechanical Printer Assembly Cards . . . . .	7-6
Features and RPQs . . . . .	7-7
<b>3288 Model 2 EC Cross-Reference</b> . . . . .	7-14
<b>3288 Service Aids</b> . . . . .	7-16
Forms Jamming . . . . .	7-16
VFC Problems . . . . .	7-16
Forms Design Considerations and Specifications . . . . .	7-16
Transducer . . . . .	7-24
Cover/End of Forms/Throat Switches . . . . .	7-24
Power Supply . . . . .	7-26
Parts Catalog Corrections . . . . .	7-26
Belt Speed Problems . . . . .	7-27
Type Belt Part Numbers . . . . .	7-31
Installation of Ribbon Cassette . . . . .	7-31
Ribbon Jamming or Feeding Problems . . . . .	7-31
Text Print Feature . . . . .	7-31
CE Test for Text Print Feature . . . . .	7-31

### Figures

Figure 7-1.	3288 Block Diagram . . . . .	7-9
Figure 7-2.	3288 A-Gate Card Layout by Function . . . . .	7-10
Figure 7-3.	Logic Board Layout . . . . .	7-11
Figure 7-4.	Printer Card Gate Layout . . . . .	7-12
Figure 7-5.	Print Head Plug Description . . . . .	7-13
Figure 7-6.	3288 Model 2 EC Cross-Reference Chart (2 parts) . . . . .	7-14
Figure 7-7.	Platen Assembly . . . . .	7-17
Figure 7-8.	Generally Available Form Widths . . . . .	7-18
Figure 7-9.	Recommended Form Lengths . . . . .	7-19
Figure 7-10.	Margin Dimensions . . . . .	7-20
Figure 7-11.	Fastening Requirements for Multiple-Part Forms . . . . .	7-21
Figure 7-12.	Overall Forms Dimensions (2 parts) . . . . .	7-23
Figure 7-13.	Cover/End of Forms/Throat (Hall Effect) Switches . . . . .	7-25
Figure 7-14.	Platen/Ribbon Shield Assemblies . . . . .	7-27
Figure 7-15.	Print Belt Motor Drive Pulses . . . . .	7-29
Figure 7-16.	Ribbon Lift Arm Assemblies (Old and New Styles) . . . . .	7-30



## Section 7. 3288 Line Printer

Figures 7.1 through 7.6 give the locations for the 3288 Line Printer.

### 3288 SYMPTOM FIX LIST

The following Symptom Fix List should be used to supplement the existing troubleshooting procedures in the MLTG.

Symptom	Fix
Belt drive slow and noisy, Not Ready	Loose flywheel retaining screws, loose belt idler pulley, or oil contamination on belt or belt drive (clean with alcohol)
CE Test Overprints	Text Print Feature installed. Jumper C2U13 to DC return (D08) for test only. See Appendix B in MLTG.
Drops print positions	01A-A1A2
Drops ready	PC1 Fuse 1 (-5V)
Fails to print first buffer load	Program problem - input length exceeded buffer size
Hammers fail to fire	01A-A1A2
Hammers fire on power up, won't Ready	PC1 Fuse 2 (+8.5V) or 24V contactor
Hammers fire on power up	Loose screw on power supply capacitor or loose connection power supply terminals
Hammers pick when powering off, won't Ready	Printer circuit board defective
Hammers pick when powering off	01A-A1B2 or 24V contactor
Light print or poor impression	Low 24V, loose connector at J3 plug on board 01E-HS1, HS2
Print Belt runs continuously	Normal operation for 3288
Prints wrong characters	01A-A1A2
Ribbon jam	Excessive clearance between drive rollers and drive roller shaft, or idler rollers and idler roller shaft
Ripple print failure	PC1 Fuse 3 (-12V)
Ripple print - slow or offset to right	01A-A1D2
Type belt drive motor fails to turn	Printer interposer circuit board defective A13 side
VFC Feature prints one line low on all but first page	VFC Feature not supported by CICS. Put (FF) Form Feed character in first data position.
VFC restore operation stops short	Cold solder connection on VFC switch unit

#### Notes:

- Intermittent forms jams or dropping Ready can be caused by improper grounding of the metal components in the exiting forms path. Ensure that the spring clip, which is mounted to the frame, is making good contact with the guide plate. This guide plate is located behind the upper paper clamp.
- Intermittent Sync checks - ensure the following components are free of oil:
  - Type belt
  - Surface of transducer bearing
  - Type belt idler rollers
  - Type belt pulleys

The following symptom index is intended to aid the CE in quick identification and correction of printer failures when they occur. In nearly all cases, an associated MAP is referenced for each symptom. Also, logic cards deemed suspect when that failure symptom occurs are listed (Card Caddy Quick-Call Fix List). The logic cards are listed in the order in which they are likely to fail.

In those cases where symptoms are not referenced to a MAP, references are made directly to those cards that should correct the problem. Should the suspect cards listed for a particular symptom fail to correct the failure, entry into the corresponding MAP must be made in order to further identify and correct the cause of the failure.

Symptom	MAP	Card Caddy Quick-Call Fix List
<b>System Reported Status (CPU Printouts)</b>		
Printer not available; Intervention Required and not Unit Specify	5.6.2	F2, G2
Printer always responds busy	5.2.3	C2, D2, F2, H2, B2
Printer always responds busy – No Start Print issued	None	G2
Printer responds with Equipment Check and Unit Specify (sync check)	5.1.5	13A, A2, B2, C2, G2
Printer responds with Data Check and Unit Specify (parity error)	5.6.1	J2, J3, J4, J5, H2, C2, G2
Printer responds with Intervention Required (not ready)	5.1.1	G2
Printer responds with Intervention Required, Equipment Check, and Unit Specify (hammer fire check)	5.1.6	A2, B2, 23A, 23C, 23E
Printer causes continuous system interrupts	None	F2, G2
<b>Printer Power and Not-Ready Failures</b>		
Printer not ready without Ops Chk blinking	5.1.1	G2
Printer not ready with Ops Chk blinking	5.8.2	F2, 13A, D2
Sync check	5.1.5	13A, A2, B2, C2, G2
Hammer check	5.1.6	A2, B2, 23A, 23C, 23E
Power failure in printer	5.1.7	B2
Type belt motor does not start or continue running	5.1.3	F2, B2, 13A, 13E
Type belt motor runs, but printer not ready	5.1.4	13A, 13E, B2, F2, C2, G2
Hammers fire on Power Up or Power Down	5.1.7	B2
<b>Printing and Print Quality Failures</b>		
(These failures may be due to out-of-spec forms. Refer to the <i>Forms Design Reference Guide for Printers</i> , GA24-3488, Version 10 or later.)		
Fails to print (nothing prints)	5.2.1	13A, D2, B2, F2, C2, A2, B2, E2
Fails to print (hangs busy)	5.2.3	C2, D2, F2, H2, B2
Print failures (missing or blank print positions)	5.2.2	23A, 23C, 23E, A2, B2
Inferior printing	5.3.1	None
Prints Xs in place of correct character	5.6.1	J2, J3, J4, J5, H2, C2, G2
Smudged printing	5.3.2	C2, D2, 13A, A2, B2
Wavy printing	5.4.4	D2, 13E
Continuous printing	5.3.10	E2, C2, D2, A2, B2, H2, F2
Vertical registration failures	5.3.4	None
Horizontal registration failures	5.3.5	None

Ribbon smudging	5.3.2	C2, D2, 13A, A2, B2
Ribbon failures	5.3.7	13E, D2
Wrong characters print	5.3.8	C2, B2, A2
Some characters missing from printouts	5.3.11	C2, B2, A2
Shadow printing	5.3.2	C2, D2, 13A, A2, B2
Light printing	5.3.9	None
Crooked printing	5.4.4	D2, 13E
Vertical character cutoff	5.3.5	None
Horizontal character cutoff	5.3.3	None

Symptom	MAP	Card Caddy Quick-Call Fix List
<b>Paper Transport Failures</b>		
Forms movement failures	5.4.1	D2, F2, A2, C2, B2, E2
Forms do not move	5.4.1	D2, F2, A2, C2, B2, E2
Forms do not move during printing but "Carriage Restore" operation works	None	C2, D2, B2
Carriage feeds continuously	5.4.2	F2, C2, D2, 13A
Forms move to wrong position	5.7.1	C2, F2
Skipping wrong	5.7.1	C2, F2
Overspacing	5.4.3	None
Underspacing	5.4.3	None
Forms jamming (true paper jam)	5.4.4	13A, D2, 23G
Forms jam (false jam detect)	5.4.5	13A, D2, 23G
End-of-forms failures	None	13A, D2
Acoustic failures (paper clamp failure)	5.4.4	D2, 13E
<b>Offline Test Mode Failures</b>		
CE switch failures	5.8.1	F2
No printout in either mode; Printer hangs busy	5.2.3	C2, D2, F2, H2, B2
Prints H pattern OK but fails on ripple print test	5.3.10	E2, C2, D2, A2, B2, H2, F2
Prints H pattern OK but prints all Xs on ripple test	5.6.1	J2, J3, J4, J5, H2, C2, G2
Prints ripple test OK but fails on H pattern	None	F2, D2, C2, B2, A2
<b>Intermittent Failures</b>	5.5.1	None
<b>Feature Failures</b>		
VFC	5.7.1	C2, F2
X-error print	5.7.2	D2, C2
TEXT PRINT (Printer does not execute line suppress orders)	5.7.3	C2, D2
<b>Operator's Panel</b>		
Ops Chk indicator blinking	5.8.2	F2, 13A, D2
Indicator	5.8.1	G2, F2, D2, H2
Switch failures	5.8.1	G2, F2, D2, H2
Interlock Failures	5.8.3	D2, F2, 13A

### 3288 CARD SUBSTITUTION LIST

**Key**

- MAND = Mandatory EC
- OPT = Optional EC
- CC = Companion Card Required
- BW = Board Wiring Required
- MR = Minimum Rework - functional equivalent to PN listed immediately below it.

The underlined PN is the latest level card.

Cards may be substituted up or down as long as board wiring (BW) is not required.

**Basic Unit**

Loc	PN	Key	ECA/EC	Function/Comments
A2-----	2624074 <u>4104</u>		NA/740039 NA/741259	Special Adapter
B2-----	2624102 2624112 1590608 <u>1590624</u>	MR	NA/740039 NA/741259 NA/741259 NA/744150	Special Adapter
C2-----	8526674 6065 7991 7992 <u>8265</u>	MR	NA/740865 NA/740865 NA/743321 10/743321A	Adapter  Do NOT use with Katakana
D2-----	8526066 6067 7307 7984 7985 <u>7995</u>	MR  MR	NA/740865 NA/740865 NA NA/742877 8/742877B 9/743324	VFC Paper Movement  FBM replaces all previous part numbers
E2-----	<u>8521492</u>		NA/717487	Counters & Compare
F2-----	8526675 <u>8528259</u>		NA/740865 NA/743333	VFC Carriage Restore
G2-----	8524595 <u>4596</u>	MR	NA/740033	SERDES
H2-----	<u>8521731</u>		NA/717480	ERASE/WRITE/RESET
J2-5-----	<u>8521985</u>		NA/717487	Buffer

**Mechanical Printer Assembly Cards**

Loc	PN	Key	ECA/EC	Function/Comments
13A-B	8522301 <u>1815438</u>		NA 7/742627	Basic Control FBM replaces previous part number
13E-F	<u>5863910</u>		NA	Motor Driver
23A,C, &E	8235829  1821382 <u>8238903</u>	MR	NA NA	Hammer Driver
23G	5863988 4257 4320 <u>4327</u>		NA NA NA 6/742623	Sense Amp.  FBM replaces all previous levels

**Features and RPOs**

Loc	PN	Key	ECA/EC	Function/Comments
C2-----	<u>8528263</u>		NA	Text Prt Feature
D2-----	<u>8528264</u>		NA	Text Prt Feature

*Note:* Logic board 01A-A1 (PN 1657198) must be at EC 742879 or higher for the Text Print Feature to work. If no EC level can be found on the board, check for continuity between A1C3D11 and A1D3D06. If continuity exists, the board is at EC 742879, or higher. A special print belt allows printing the 120-character set.



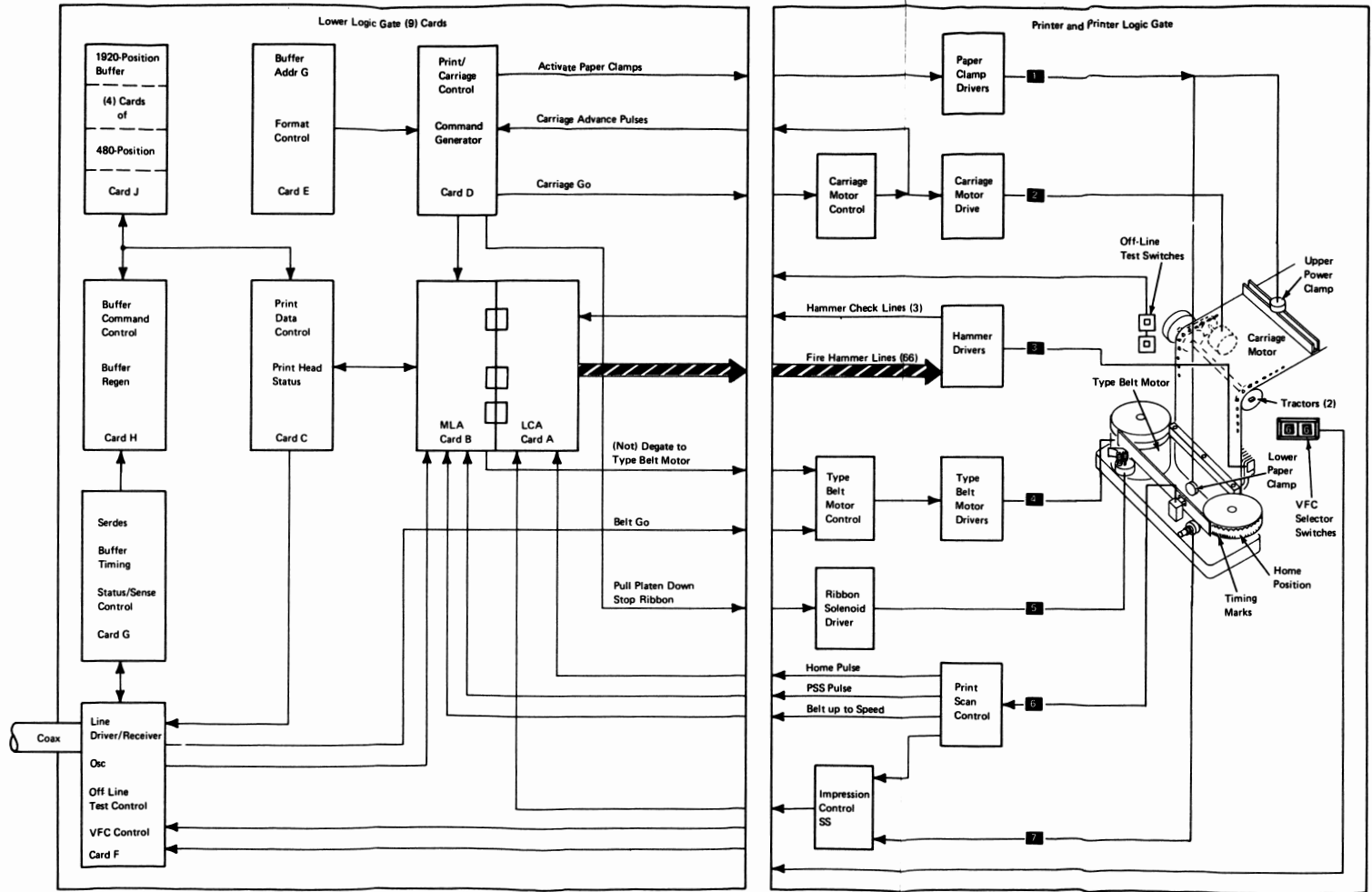
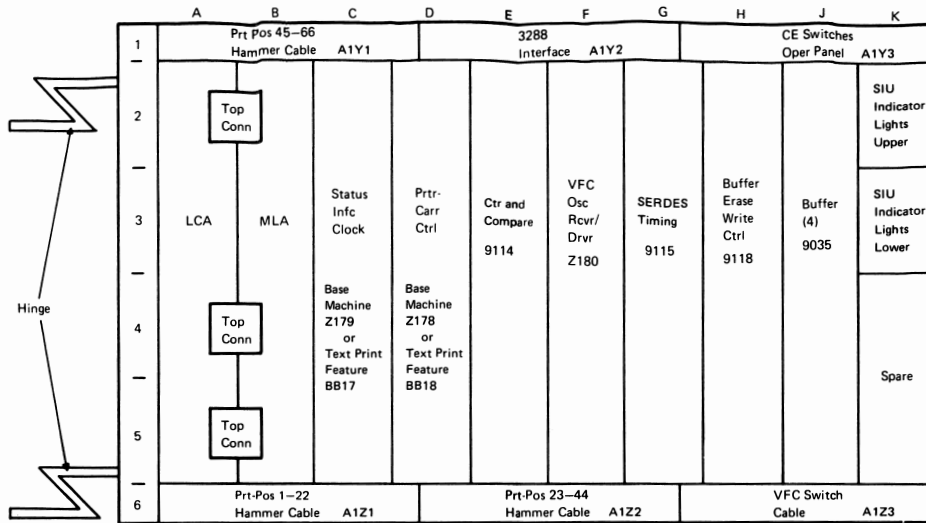

Figure 7-1. 3288 Block Diagram



Logic Gate Front View Card Side

Figure 7-2. 3288 A-Gate Card Layout by Function

### Printer Card Gate Connector Details

This illustration is the top view of the card gate assembly in the *raised* position as seen from the *rear* of the machine. For ease in determining pin designations, all probing should be done from the rear.

Cards are plugged into rows 2 and 3. The outside two rows 1 and 4 are for probing. Pins 02 through 13 are connected one-for-one with pins 42 through 53; pins 22 through 33 are connected one-for-one with pins 62 through 73.

To determine a probe pin when given a signal pin, add 40 to the signal pin.

Example: Signal 13C06 - Probe 13C46.

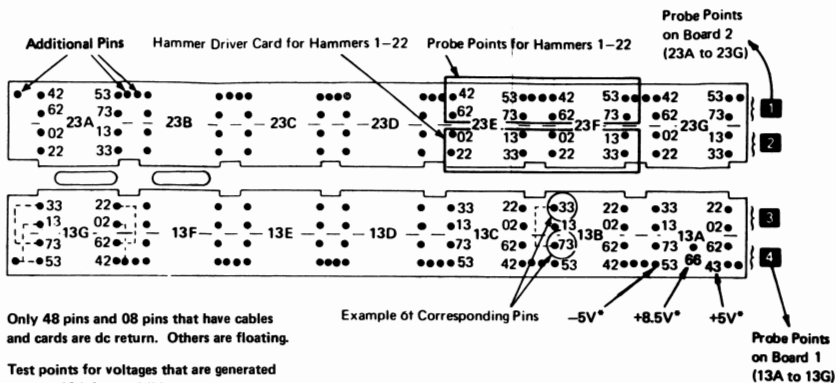

Only 48 pins and 08 pins that have cables and cards are dc return. Others are floating.

Test points for voltages that are generated by card 13A from +24V.

\*Tolerance = 10%

Figure 7-4. Printer Card Gate Layout

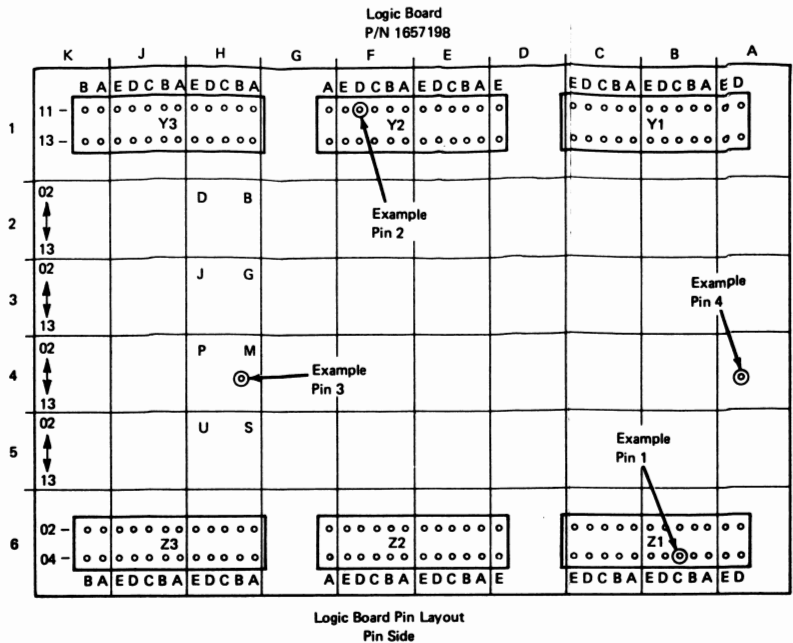

Examples: Pin 1 ⇒ B6C04  
 Pin 2 ⇒ F1D11  
 Pin 3 ⇒ H4M06  
 Pin 4 ⇒ A4D07

Figure 7-3. Logic Board Layout

P1, P2, P5, P6, P8, P11

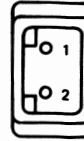

2 pos inline connector  
5214573, contact 116614 or  
483999 mates with 5214572,  
contact 1166115 or 2513254

P3, P5, P9, P10

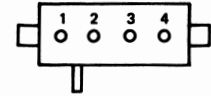

4 pos connector 1812491 contact 1166115 or  
2513254 mates with connector 1812492,  
contact 1166114 or 483999

Plug Description	Positions
P1 - Ribbon Solenoid	2
P2 - Not used	2
P3 - Lower Paper Clamp	4
P4 - Belt Motor	9
P5 - Emitter Potentiometer	4
P5 - Emitter	2
P6 - Contactor	2
P7 - Carriage Motor	9
P8 - Upper Paper Clamp	2
P9 - Paper Jam Sensor	4
P10 - Not Used	4
P11 - AC Fan	6
P12 - Not Used	9
P13 - Potentiometer	3 Note 2
P14 - 24V Interlock	2 Note 2

**Notes:**

- When P13 is used, P5 is a 2-position plug.
- P13 and P14 are not used on all machines.

Figure 7-5. Print Head Plug Description

P11

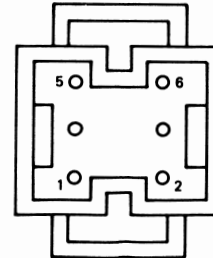

6 pos connector 1160983,  
contact 1166114, mates with  
1160977, contact 1166115

P4, P7, P12

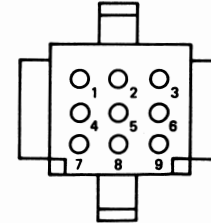

9 pos connector 1166498,  
contact 1166115 mates with  
1166499, contact 1166114

P13

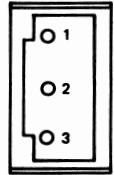

3 pos connector 1166117  
contact 483999, mates with  
1166116, contact 2513254

### 3288 MODEL 2 EC CROSS-REFERENCE

This chart (Figure 7-6) is to be used to determine the need for any of the optional EC changes and to verify the EC level of any machine. To aid in determination the serial number that implemented each change is listed. This list will be updated periodically. It is recommended that a copy of this service aid be kept in 3270 card caddies.

ECA	EC	REA	Pre-Req ECA	Concur or Comp	Opt/Mand	Feature Affected	Break In Serial #	Cards Affected		Board Wiring Involved	Card Loc	Card Type	Description
								Old P/N	New P/N				
001	741681	None	None	None	Mand	Basic	NA	NA	NA	None	NA	NA	Change the value of F2 and F6
002	741685	None	None	None	Mand	Basic	NA	NA	NA	None	NA	NA	Shunt stepper motor noise to frame ground
003	741680D	None	None	None	Mand	Basic	NA	NA	NA	None	NA	NA	Ground covers.
004	742622	None	None	None	Mand	Basic	NA	NA	NA	None	NA	NA	Replace upper paper clamp.
005	742624	None	None	None	Mand	Basic	NA	NA	NA	None	NA	NA	Safety fans
006	742623	None	None	None	Mand	Basic	NA	5863988 5864257 5864320	5864327	None	23G		New jam detect card.
007	742627	None	None	None	Mand	Basic	NA	8522301	1815438	None	13A		Prevent false paper jams.
008	742877	None	None	None	Opt	Basic	NA	8526066 8526067 8527307 8527984	8527985	None	A1D2	Z178	Superseded by ECA 009.
009	743324	None	None	None	Mand	Basic	NA	8527985	8527995	None	A1D2	Z178	Reduce ESD problems and fix extra indexes
010	743321	None	None	None	Mand	Basic	NA	8526674 8526065 8527991	8527992	None	A1C2	Z179	Prevent dropping ready after operator intervention
011	743346	None	None	None	Mand	Basic	NA	NA	NA	None	NA	NA	Remove ESD from paper guides to reduce jams
012	743357	None	None	None	Mand	Basic	NA	NA	NA	None	NA	NA	Ground cover to reduce jams and dropping of ready
013	744580	None	None	None	Mand	Basic	NA	NA	NA	None	NA	NA	Install two caps to reduce ESD

Figure 7-6 (Part 1 of 2). 3288 Model 2 EC Cross-Reference Chart

ECA	EC	REA	Pre-Req ECA	Concur or Comp	Opt/ Mand	Feature Affected	Break In Serial #	Cards Affected		Board Wiring Involved	Card Loc	Card Type	Description
								Old P/N	New P/N				
014	744581	None	None	None	Mand	Basic	NA	NA	NA	None	NA	NA	Belt cleaner and bearing - eliminate noise, wear, and red dust
015	744582	None	None	None	Mand	Basic	NA	NA	NA	None	NA	NA	Replace ribbon bar assembly to eliminate ribbon roll wear.
016	742626	None	None	None	Opt	Basic	16604 (sequence)	NA	NA	None	NA	NA	Increase print density and to eliminate ribbon lift up.
017	743355	None	None	None	Opt	Basic	NA	NA	NA	None	NA	NA	Control idler pulley float.
018													WTC only.
019	742639	None	None	None	Opt	Forms Stand	NA	NA	NA	None	NA	NA	Grounds form stand.
020	347977	None	013	None	Mand	Basic	NA	NA	NA	None	NA	NA	Corrects ECA 013.

*Note:* This chart is to be used to determine the need for any of the optional EC changes and to verify the EC level of any machine. To aid in determination the serial number that implemented each change is listed. This list will be updated periodically. It is recommended that a copy of this service aid be kept in 3270 card caddies.

**Figure 7-6 (Part 2 of 2). 3288 Model 2 EC Cross-Reference Chart**

## 3288 SERVICE AIDS

### Forms Jamming

Forms jams and/or belt speed checks may be caused by a defective ribbon shield, PN 1794711. They may be caused by a ribbon shield with an incorrectly formed metal guide, which can be detected by viewing the thin metal guide of the shield from the end. Good shields have a metal guide with a 7-degree bend that brings the guide to a vertical plane. Defective shields do not have a bend and cause interference with the paper (high drag through the throat area) and underscoring of characters on the last part of the multipart forms.

PN 1794711 is now obsolete. If you have a problem in this area, order the following as required: (1) ribbon shield, PN 1794752 or 1794856, and (2) bearings (grooved), PN 1794805 or 1800540, or bearings (smooth), PN 1794748 or 1821358. (See Figure 7-7.)

Gauge kit, BM 1815365, is required when initially installing the new shield. See par. 6.3.3 of the MLTG, Form SY27-2401-2 or higher level, for proper use of the gauge kit.

### Highly Intermittent Jams

You may be experiencing forms jams if the inside corners of the upper paper guide, PN 1811025, protrude into the paper path. Check the guide with a straight edge; if they do jut into the paper path, bend them back in. This problem will show up more when the customer is using maximum width form.

### Forms Jamming Due to Wrong Paper Stand and/or to Missing Grounds

1. The 3286 forms stand, which has two shelves, should not be used with the 3288. This printer must have clearance between the busel and the top shelf of the forms stand for the paper to drop at least two full pages. The 3286 stand can be modified by removing the top shelf.
2. When using a single-part form, forms jams can occur at the upper paper clamp, if the form does not enter the rear of the machine straight. This usually happens after a skip operation (VFC). The feed holes may also be torn.
3. Static can also cause forms jams. Ensure that all covers forms guides are connected to frame ground. See ECA 003, ECA 011, ECA 012, and ECA 019.
4. Paper can jam behind the upper paper clamp if the bulb seal, between the guide, PN 1815282, and the printer casting, obstructs the paper path. The bulb seal PN 1800936 has been redesigned and is replaced by PN 1794922.

### VFC Problems

- Verify that the jumper is installed between 01A-A1C2J06 and 01A-A1C2J08.
- If normal indexing does not occur after each print line, then the trouble is probably not in the VFC feature.
- If restore key operation works properly and programmed skip is not working, replace A1C2 and/or A1F2.
- If restore key operation does not work properly, use the MAPs, SIU, and Appendix B in the MLTG.

### Forms Design Considerations and Specifications

#### Paper Quality

Paper for continuous forms must be of sufficient weight and strength to prevent the margin holes from tearing out during form-feeding, skipping, and ejecting operations. This is important, particularly for single-part forms.

The form when removed from the carton must be flat, and the edges and folds must not be damaged. The assembly of multiple-part forms must be even and the perforations intact when forms are stacked before feeding.

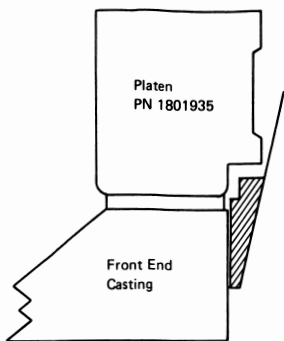

Guide Bearings  
Smooth PN 1821358  
Grooved PN 1800540

Shield  
PN 1794711

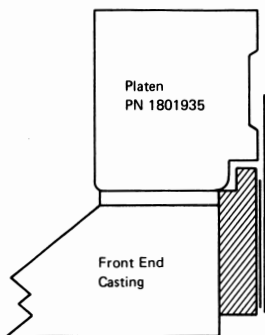

Guide Bearings  
Smooth PN 1794748  
Grooved PN 1794805

Shield  
PN 1794752

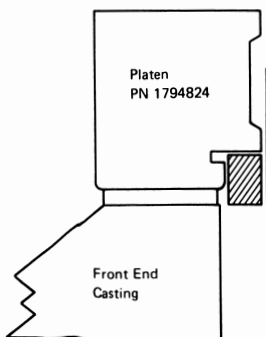

Guide Bearing  
Smooth PN 1794748

Shield  
PN 1794856

**Figure 7-7. Platen Assembly**

The paper must not be so stiff as to cause improper feeding or excessive bulging, particularly at the outfold, and should be free of paper dust and lint.

Optical character reading applications require high-grade stock and tighter control of paper qualities than paper for other applications. If a prepared document is to be read by an OCR reader, refer to the appropriate reader literature for the proper paper and ink qualities necessary in the form design. Generally, a minimum weight and type of 20-lb bond (75 g/m<sup>2</sup> OCR form) with a smoothness within a range of 65 to 130 Sheffield units (as measured with a Sheffield Tester\*) maximum is recommended. Additional references for OCR specifications are: *American National Standard Character Set and Print Quality for Optical Character Recognition (OCR-A)*, ANSI X3.17-1974, and *ANS Character Set for Optical Character Recognition (OCR-B)*, ANSI X2.39-1975.

#### Form Width

Figure 7-8 shows the common form widths which printers are normally capable of handling. Refer to the print format capability of any particular printers.

**Note:** Narrow width forms contribute to instability of stacker height and may require operator stacker attention. Therefore, wider base forms are recommended.

#### Form Length

The forms-control method determines the forms-length capability of a printer. See the form-length specifications for each printer. Before ordering a nonstandard form length, consult your IBM sales representative and your forms supplier. Common form lengths are shown in Figure 7-9.

For printing six lines to the inch, the length of the form or document must be evenly divisible by 0.167 in. (4,24 mm) for single-spacing. Similarly, printing eight lines to the inch requires the length of the form to be evenly divisible by 0.125 in. (3,18 mm) for single-spacing.

Because all characters can be printed in every position, form length can be reduced and ribbon life extended by printing information side by side.

Overall Width		Hole-to-Hole Width	
in.	mm	in.	mm
4.75	120,7	4.25	108,0
5.75	146,1	5.25	133,4
6.50	165,1	6.00	152,4
8.00	203,2	7.50	190,5
8.50	215,9	8.00	203,2
9.50	241,3	9.00	228,6
9.875	250,8	9.375	238,1
10.375	263,5	9.875	250,8
10.50	266,7	10.00	254,0
10.625	269,9	10.125	257,0
11.00	279,4	10.50	266,7
11.75	298,5	11.25	285,8
12.00	304,8	11.50	292,1
12.844	326,2	12.344	313,5
13.00	330,2	12.50	317,5
13.625	346,1	13.125	333,4
14.375	365,1	13.875	352,4
14.875	377,8	14.375	365,2
15.50	393,7	15.00	381,0
16.00	406,4	15.50	393,7
16.75	425,5	16.25	412,8
17.78	451,6	17.28	438,9

Figure 7-8. Generally Available Form Widths

\* A product of Sheffield Corporation

Length	
in.	mm
3.00	76,2
3.50	88,9
3.67	93,2
4.00	101,6
4.25	108,0
5.00	127,0
5.50	139,7
6.00	152,4
7.00	177,8
8.00	203,2
8.50	215,9
10.00	254,0
11.00	279,4
12.00	304,8
14.00	355,6
16.00	406,4
17.00	431,8

For stacking efficiency, these form lengths should be fanfolded in two- or three-up multiples.

**Figure 7-9. Recommended Form Lengths**

#### Vertical Lines

When preprinted vertical lines are required, ruling on the form can split adjacent print positions for assigning particular positions in a columnar field. For best results, however, a vertical line should occupy at least one character space. Preprinted vertical lines should be parallel to the vertical center line through the margin holes, spaced in multiples of  $0.100 \pm 0.005$  in. ( $2,54 \pm 0,13$  mm).

#### Horizontal Lines

Preprinted horizontal lines should always be perpendicular to the center line of the margin holes.

#### Margins

The distance from the form edge to the margin tear strip is normally 0.50 in. (12,7 mm). See Figure 7-10. However, this dimension may vary for special applications. In such instances, the minimum dimension of the first and last print position carriage translation should be adjusted accordingly.

For a form without a margin perforation, the first (or last) character of a print line should be at least 0.438 in. (11,1 mm) from the edge of the form. With a friction-feed platen, printing can take place to the edge of the form, except as noted for specific printers.

#### Margin Holes

Continuous forms having feed holes (margin holes)  $0.156 \pm 0.004$  in. ( $4,0 \pm 0,1$  mm) in diameter (see Figure 7-10) in both the right and left margins are preferred. Serrated margin holes 0.156 in. inside diameter (ID) and 0.172 in. outside diameter (OD) ( $4,0$  mm ID and  $4,4$  mm OD) are also permissible. Spacing between holes, center to center, must be nominally 0.50 in. (12,7 mm). The margin holes should be free of chads. Presence of chads on the print line can cause loss of printed characters.

To ensure proper feeding, the two vertical rows of margin holes must be parallel. The recommended distance from the edges of the form to the center line of the margin holes is  $0.236 \pm 0,028 - 0,020$  in. ( $6,0 + 0,7 - 0,5$  mm). For calculation purposes, 0.236 ( $6,0$  mm) should be treated nominally as 0.25 in. ( $6,4$  mm). See Figure 7-10.

To allow for carbon shrinkage and processing tolerances, margin holes in the carbon paper should be 0.156 in. ( $4,0$  mm) in diameter.

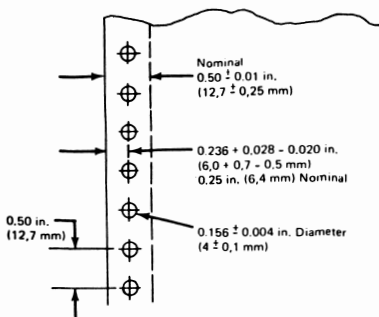

**Figure 7-10. Margin Dimensions**

### Perforations

Perforations should permit easy separation, but should not tear or catch in ordinary handling or feeding through the printer. Perforations should be uniform in length and spacing to ensure proper and efficient tearing.

*Margin Perforations:* The distance from the edge of the form to the margin perforations is usually 0.50 in. (12.7 mm); however, this width may vary.

*Forms Perforations:* Horizontal perforations between forms should be perpendicular to the center line of the margin holes.

### Forms Stacking

Forms stacking is affected by relative humidity, number of plies, and form length. For best operation, forms should be preconditioned, not less than 48 hours, in the environment of the printer.

Stacking efficiency diminishes for form lengths less than 8 in. (203 mm) or greater than 12 in. (305 mm). Test such forms to ensure individual stacking requirements are met. Forms over 17 in. (432 mm) long usually require manual assistance to assure proper stacking, and, for some printers, may extend beyond the limits of the machine. When a forms stand is used, the dimensions of the form should not exceed the dimensions of the stacking tray.

### Multiple-Part Forms

The number of legible copies needed is a factor in determining the weight of the paper and carbon to be used in multiple-part sets. Single-part forms of less than 15-lb (56 g/m<sup>2</sup>) or more than 24-lb (90 g/m<sup>2</sup>) stock should be tested prior to batch ordering of forms.

Multiple-part forms are generally composed of sheets, 12- to 13-lb stock (17 x 22 in.—500 sheets: 45 to 49 g/m<sup>2</sup>) or less. For special applications, carbonized paper or carbonless forms can be used to obtain extra legible copies.

The carbon paper used in multiple-part forms should be medium carbon, 8- to 9-lb (30 to 34 g/m<sup>2</sup>) or less. Multiple-part forms consisting of more than four parts, and forms with the first part of more than 13-lb (49 g/m<sup>2</sup>) paper should be tested under operating conditions to determine the suitability of feeding and legibility.

### Registration

In some printers, because of the bend of the form over a platen, a small dimensional difference may occur between printed lines on successive parts of a multiple-part form. This difference, more noticeable on loosely fastened forms, is proportional to the thickness of the form. Because of this, the assembly of multiple-part forms should ensure that all punching and printing is in registration within 0.015 in. (0.38 mm).

Single-space, eight-lines-per-inch printing is not recommended with 0.095-in. (2,41 mm) type when the registration between lines is critical.

### Fastening

The width, length, and number of copies of the form determine the fastening requirements for satisfactory feeding through a printer. If the construction of the form is such that the parts are of different widths, the necessity for, and the method of, fastening the form should be determined by the weight of paper, the width of the parts, and the length of the form (Figure 7-11). For forms over 17 in. (432 mm) in length, the maximum distance between fastenings should be determined by actual test.

For maximum efficiency, forms should be tightly fastened on both sides to prevent copies from shifting. Print quality and forms feeding are adversely affected by loosely applied plies.

The security of the fastening becomes more important as the number of parts, width of form, or the humidity increases. For relative humidity near 80 percent, both margins should be fastened by a method unaffected by high humidity, such as gluing or stitching.

Forms should be fastened only in the margins. Avoid using metallic staples or any hard fasteners with multiple-part forms. In no case should metal or hard fasteners be located so that they pass the printing unit.

Fastening of forms on the horizontal perforations between margins is not recommended. If a fastening medium is inserted on the perforated line, no printing should be within 0.25 in. (6,4 mm) above and below the perforated line.

Multiple-part forms in which individual parts vary in width should be tested before quantity-ordering. If multiple-part forms are not fastened, print quality may deteriorate.

The carbon paper must be kept in line with the form by some acceptable method. One method is to use narrow-width carbon glued to the set. Another is to use full-width carbon paper punched with substantially larger margin holes that are approximately centered with the corresponding holes in the form. Oversize marginal holes in the carbon allow for carbon shrinkage and provide the processing tolerance necessary for some commonly used form structures.

One-time carbon paper or carbon-backed paper can also be used. The selection of proper carbon paper or coating is a prime factor in determining the required number of legible copies without excessive smudging. Determine this by making test runs with sample sets of forms containing different qualities of carbon papers, known as *write test carriers*. Use these carriers with caution to avoid damage to the printer or form.

Form Length		Maximum Distance Between Fastenings	
in.	mm	in.	mm
1 to 5	25,4 to 127,0	5	127,0
5.50 to 11	139,7 to 279,4	11	279,4
11 to 14	279,4 to 355,6	7	177,8
14 to 17	355,6 to 431,8	8.5	215,9

Figure 7-11. Fastening Requirements for Multiple-Part Forms

## **Print Legibility**

The number of legible copies produced depends on the weight of the paper used and the carbon coating.

For multiple-part forms beyond the original and three copies, the paper and carbon should be tested with the proper machine settings to determine the suitability of each combination. Some printers have forms-thickness and/or print-density adjustments to accommodate multiple copies and provide optimum legibility within a range of settings.

Form sets used on one printer (or model of a printer) may not produce acceptable results when used on another printer (or model of the same printer). Tests should be made under actual operating conditions.

Paper (and ribbon) for applications, such as optical character reading, ditto, photo-offset, multilith, heat transfer, or similar processes, must be tested to ensure that its use satisfactorily meets individual requirements.

Print legibility on multiple-part forms may vary within a box due to tolerances of the paper and the carbon, temperature, and age of the carbon.

## **Card Forms**

Card forms should be selected from card stock not exceeding 0.009-in. (0.23-mm) thickness. Preferably, card seams or scores should be lapped so that the upper card overlaps the lower card to provide a smooth feeding surface on the front of the form.

Folding specifications recommended for continuous card forms for some printers are three or four up for optimum stacking. See specific printers. Operator attention is normally required to assure efficient stacking on all printers. Long-grain stock is recommended.

Special card forms should be tested to ensure that they satisfactorily meet individual requirements.

## **Graphics**

Graphics specified by the USA and ISO Standard Codes for Information Exchange are available for most system printers. All characters and symbols installed can be printed at every print position. Because of this, form depth can be reduced by using side-by-side printing. For example, ordered-by and ship-to names can be printed on the same line, one on the left side of the form and the other on the right.

In many instances, oblique lines, dashes, and so forth can be used instead of preprinting margin enclosures and separators. However, long vertical lines should be avoided as repeated impact in a single print column can cause ribbon damage when using line printers. The dollar symbol need not be preprinted on a check form because this symbol can be programmed to print immediately to the left of a significant digit.

Special type fonts for plotting and unique symbols can be ordered through an IBM sales representative.

## **General Forms Specifications**

Figure 7-12 gives the overall forms dimensions.

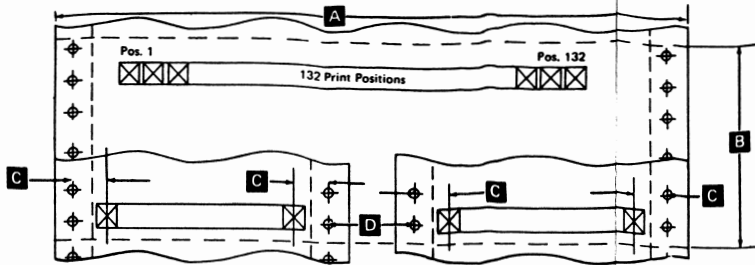

**A** Form Width (Single- or Dual-Feed Carriage)

Maximum

Minimum

**B** Form Length (Single- or Dual-Feed Carriage)

15 in. (381 mm) See Note 10

3.5 in. (88.9 mm)

**C** Carriage Spacing—6 lines per inch only.

14 in. (355.6 mm)

3 in. (76.2 mm)

**D** The maximum distance from the center line of the left margin hole and center line of print position No. 1 is 0.55 in. (13.9 mm) with the left tractor in leftmost position.

A maximum of 0.50 in. (12.7 mm) if interchangeability with the 3715, 3771, 3773, 3774, or 5320 A Model printers is desired.

**Forms With 0.50 in. (12.7 mm) Tear Strips (Single- or Dual-Feed Carriage)**

The distance between the center line of a margin hole and the center line of the first available print position is:  
0.30 in. (7.6 mm) minimum with odd print position and  
0.40 in. (10.2 mm) minimum with even print position.

The distance between the center line of a margin hole and the center line of the last available print position is:  
0.30 in. (7.6 mm) minimum with even print position and  
0.40 in. (10.2 mm) minimum with odd print position.

[For a 132-print position printer, the maximum forms width for which these distances are obtainable is 14.375 in. (365.1 mm) with left tractor in the leftmost position.]

**Note:** Separation of the perforation may occur as the 0.30 in. (7.6 mm) minimum dimension above is approached.

**Forms Without Tear Strips (Single- or Dual-Feed Carriage)**

The distance between the center line of a margin hole and the center line of the first available print position is:  
0.15 in. (3.8 mm) minimum with odd print position and  
0.25 in. (6.4 mm) minimum with even print position.

The distance between the center line of a margin hole and the center line of the last available print position is:  
0.15 in. (3.8 mm) minimum with even print position and  
0.25 in. (6.4 mm) minimum with odd print position.

[For a 132-print position printer, the maximum forms width for which these distances are obtainable is 14.25 in. (362 mm) with left tractor in the leftmost position.]

**D** The fixed distance between the center line of the paper feed pins (dual-feed carriage) is 1 in. (25.4 mm).

**Notes:**

- Over 4-part forms should be tested to assure satisfactory feeding, print quality, and legibility. Modifications in forms fastening techniques, perforations, stiffness or paper quality can often overcome forms processing difficulties.
- Up to 6-part forms can be used; maximum thickness not to exceed 0.020 in. (0.51 mm). Ribbon smudging may occur as forms set approaches maximum thickness.
- a. 5320 B and 5320 C Models only:  
Cut card stock is not permitted. Continuous card stock forms are generally not recommended. (See *IBM System/32 Membership and Mailing List System Design Objectives*, GH30-0010, or *Design Specifications*, GH30-0012 for card stock specifications approved for this Industry Application Program or other user applications with card stock requirements that meet such specifications.)  
b. All other printers:  
Continuous card stock forms are generally permitted. They should be tested to assure satisfactory feeding and smudge acceptability. Cut card stock is not permitted. Card stock should not exceed 0.008-in. (0.23-mm) thickness. Overlapped glue joints are not recommended.
- Cutouts are not permitted from 2.75 to 3.25 in. (69.9 to 82.6 mm) from left edge of form with tractor in leftmost position. Cutouts in this area may cause a false end-of-forms.
- No hard or metallic fasteners are permitted.
- Fastening multiple set forms on both edges is recommended. The crimping method of fastening is recommended; however, crimps should not be within 0.50 in. (12.7 mm) of the horizontal perforation. If crimp fasteners are used, the crimps must not project significantly above the body of the form. Excessively hard or stiff crimps may interfere with proper ribbon and/or form processing operation. If a glue fastening is required, the forms should be tested for acceptable feeding.
- Feed holes should remain free of chads and crimps to avoid false form jam checks.
- Recommended that no printing occurs within 0.50 in. (12.7 mm) of the horizontal perforation.
- Sixteen-inch leaders for alignment of prenumbered documents are recommended. A narrow 3-in. (76.2-mm) long trailer (trailer not to ride over end-of-forms switch) is recommended on the last form of the form set to maintain registration on the last form.
- When using dual-feed carriage, the maximum difference of form thickness between the left and right carriage cannot be more than 0.006 in. (0.15 mm).
- Left tractor must be in the leftmost position when using maximum form width.

Figure 7-12. Overall Forms Dimensions

### Transducer

- Hard-to-diagnose problems can be caused by the transducer leads being connected backwards inside the unit. Try reversing the transducer leads.
- See MLTG Diagrams 8-20 and 8-21.
- For red dust around the transducer, verify that ECA 014 is installed.
- Transducer out of adjustment can cause horizontal character cutoff in every other position. See par. 6.3.15 in the MLTG.
- The thickness of nut PN 257189 does not allow the transducer bearing support assembly to be disassembled without removing the transducer bracket.

A thicker nut, PN 1794837, may be used which will allow the screw to reach the nut.

An alternative method would be to slide a folded piece of card stock or a feeler gauge under the nut to prevent the nut from falling to the casting.

Order nut when the transducer or bearing is replaced.

Polarity of the transducer wires must be observed.

### Cover/End of Forms/Throat Switches

These are Hall Effect switches. Do not use meter resistance scale to test because damage to switch may result.

*Note:* The old style and new style switches are not interchangeable.

Figure 7-13 illustrates the old and new style Hall Effect switches.

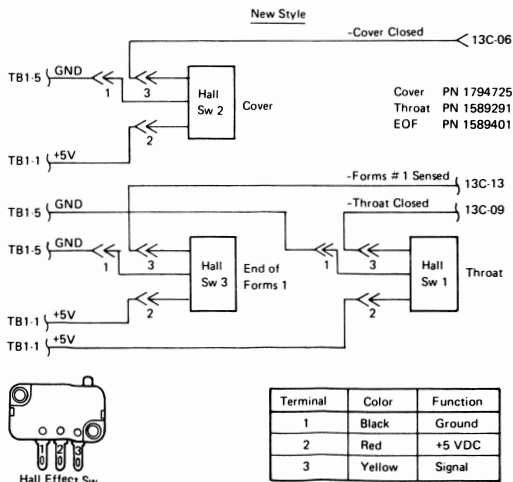
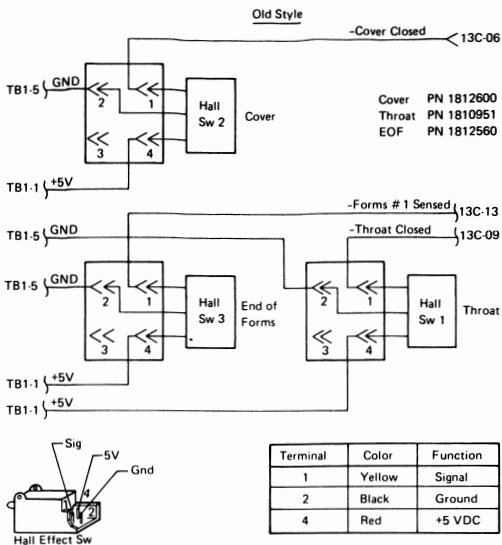

*Note:* The cover interlock switch should be checked on each service call to verify that the belt stops when the cover is open.

**Figure 7-13. Cover/End of Forms/Throat (Hall Effect) Switches**

## Power Supply

- Switched +5V on the lower logic board at 01A A1B2B13 is routed through the Power On switch. See diagrams 7-4 and 8-12 in the MLTG.
- Switched +24V is routed through the 24V contactor. See diagram 8-12 in the MLTG.
- The printer assembly card 13A generates +8.5V, +5V, and -5V from the +24V.

## Parts Catalog Corrections

Following are corrections and additions to the Parts Catalog.

Fig.	Old PN	New PN	Description
1-7	5240404	5252756	Switch
1-35A	NA	1842732	Capacitor
1-88	615683	NA	01E-PC1-F1, F2, F3 Fuse 2A SB
1-89*	107667	NA	01E-T1-F1 Fuse 6.25A SB
1-90*	237395	12471	01E-T1-F2 Fuse 12A MB
1-91*	190526	55699	01E-T1-F6 Fuse 10A MB

Note: For locations of fuses, see diagram 8-23 in the MLTG.

2-91*	1794681	NA	Latch asm
3-25*	1657198	NA	Board logic EC 742879
4-35*	1842717	NA	Resistor
5-15*	1842666	NA	Cable asm, 4 flat cables from A1Y1-A1Y2-A1Z1-A1Z2 to A23B-A13C-A23F-A23D
101-93*	2731763	NA	Board, interposer
101-152*	1589401	NA	Switch asm
102-3	1794748	NA	Bearing, flat
102-3	1794805	NA	Bearing, grooved
102-7	1794752	NA	Shield asm, ribbon (casting mounted)
102-7	1794856	NA	Shield asm, ribbon (platen mounted)
102-13	1814583	NA	Arm asm, ribbon-right (non-adjustable)
102-13	1794776	NA	Arm asm, ribbon-right (adjustable)
102-20	1814584	NA	Arm asm, ribbon-left (non-adjustable)
102-20	1794775	NA	Arm asm, ribbon-left (adjustable)
102-31	1812460	1821401	Flywheel asm
102-39	1815348	1794866	Spring, compressor
102-54	1815348	1794866	Spring, compressor
102-66	1794758	NA	Cleaner
102-68	1794753	NA	Bearing
102-70*	1794837	NA	Nut hex 8-32 (thicker nut)
102-153*	1794561	NA	Emitter, foam backing
102-154	1815365	NA	Gauge kit, platen adjustment
102-155*	1814592	NA	Bracket, ribbon arm asm (old style) left
102-156*	1814593	NA	Bracket, ribbon arm asm (old style) left
102-149A*	1801935	NA	Platen, basic (ribbon shield mounts on front casting)
102-149A*	1794824	NA	Platen basic (ribbon shield mounts on platen)
103-43*	1794941	NA	Bracket, ribbon cassette alignment
104-131*	1810951	NA	Switch asm (old style)
104-131*	1589291	NA	Switch asm (new style)
105-24	1800936	1794922	Seal
108-31*	1582879	NA	Resistor, lower paper clamp

\*Additions to Parts Catalog

## Belt Speed Problems

Belt speed checks occur under two different conditions: while printing and while starting the stepper motor.

### While Printing

This is a result of the belt's slowing down below an acceptable limit, usually as a result of extremely heavy paper binding the belt. Check paper patch clearance. The problem may also be caused by a marginally adjusted cover or print unit interlock switch.

Forms jams and/or belt speed checks may be caused by a defective ribbon shield, PN 1794711.

Forms jams and/or belt speed checks may be caused by a ribbon shield with an incorrectly formed metal guide. This can be detected by viewing the thin metal guide of the shield from the end. Good shields have a metal guide with a 7-degree bend that brings the guide to a vertical plane. Defective shields do not have a bend and cause interference with the paper (high drag through the throat area) and underscoring of characters on the last part of multipart forms. (See Figure 7-14.)

PN 1794711 is now obsolete. If you have a problem in this area, order the following: Gauge kit, B/M 1815365, is required when initially installing the new shield. See par. 6.33 of the MLTG, Form SY27-2401-2, or higher, for instructions on the use of the gauge kit.

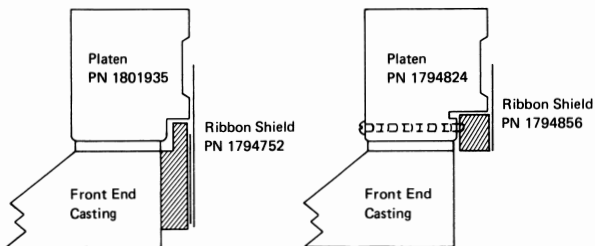

Figure 7-14. Platen/Ribbon Shield Assemblies

## While Starting Stepper Motor

This failure is a result of the oscillator and the motor getting out of step with each other. This usually falls into two categories:

1. The motor will detent and lock up without any sound. This is most likely the printer control card 13-A.
2. The motor will detent, then growl. It may or may not be turning slowly. This is caused by the oscillator running at its rated speed, but not the motor.

The following items can contribute to this problem:

- a. Marginally adjusted cover or print unit interlock switches.
- b.\* The ribbon drive belt too tight or rubbing on the motor mounting plate or on the bottom of the print belt. Place the card stock under the ribbon cassette mounting bar to tilt the bar so the belt will not rub.
- c.\* The ribbon drive belt rubbing on the ribbon cassette mounting bar. This is usually caused by the ribbon drive belt gear being upside down on the stepper motor shaft.
- d.\* The ribbon shield interfering with belt.
- e.\* Contaminants on platen and belt. The belt rubs on the platen; therefore, a very smooth finish is required. Contaminants will greatly increase the friction between the two surfaces. If contaminants are the source of the problem, the pulleys may have to be replaced, depending on what the contamination is. (Use of improper cleaning solvents destroys the pulley material.)

The belt and platen must also be cleaned with alcohol or Freon. Do not try to save time by cleaning the platen with the print unit in the machine. Take the print unit off to do a good job of cleaning the platen.

- f.\* The ribbon clutch solenoid is improperly adjusted, causing the ribbon to be engaged during stepper motor start-up. The clutch could be nipping just a little to cause the problem.
- g.\* The pulley top out. If the free-floating pulley rides up too high and comes in contact with the cover (the name given to the part on top of the pulley that has the finger holes in it), the belt must go down to achieve an equilibrium point. When the belt drives down, it puts excessive force on the two front bearings, causing wear and binds. An adjustable clevis is available if this is the problem. Order the following four parts, or order ECA 017:
  - (1) PN 1812463 Clevis
  - (2) PN 1794808 Eccentric
  - (3) PN 1794809 Pin
  - (4) PN 186929 Screw

Adjust the eccentric for 0.150 in. between the top of the pulley and the underside of the idler pulley cover.

- h.\* The pulley pivot bearing may have a bind and need a drop of No. 6 oil.
- i.\* Check for binds in floating pulleys, and replace if necessary.

Belt speed checks can be caused by a loose flywheel, PN 1812460, and/or cover, PN 1812464. The reason for their coming loose may be the result of overtightening the flywheel/cover retaining screw, PN 1091035. Over-tightening this screw can deform the flywheel/cover, causing them to wobble and resulting in the screw-loosening.

This problem can be fixed by ordering B/M 1794686 to replace flywheel PN 1812460 and/or B/M 1794685 to replace cover PN 1812464. These Bills of Material contain a flywheel/cover of the same part number. They have a counterbore on the underside of the mounting hole to accept a spacer PN 1794754, also included in the Bills of Material.

- We have even had reports of defective belts causing belt speed checks.

Failure in both modes could be caused by a defective print belt drive motor, printer control card (13A), motor driver card (13E), transducer/emitter assembly and/or cabling, and damage to the print belt transducer/emitter projections.

The asterisked items cause excessive drag on the stepper motor where it is the most susceptible to failure, that is, during startup. We can detect these in the following manner.

**Static Test:** Insert the gram gauge, with the X10 blade, in one of the holes in the front of the belt; it should require 150 grams or less of force to keep the belt moving at a constant velocity. If you have a borderline condition, use the dynamic test that follows.

**Dynamic Test:** An oscilloscope can be used to provide an indication of correct stepper motor and belt operation. The scope pictured below (Figure 7-15) shows examples of good and bad drive pulses at the P-4 connector with the motor running. The P-4 connector has six positions. The four motor drive pulses can be obtained on the two double black and the two double yellow wires located on the P-4 connector.

Notice the portion of the pulse that goes below 0V. That is called "reserve torque." Reserve torque should be at about -22 to -25V if there is no excessive drag on the belt and pulleys. You can now make adjustments or replace parts and get an immediate indication if the drag has been affected.

Additional benefits of this scope procedure are found by looking at all four phases. Loss of amplitude on the positive portions of two phases might indicate a bad capacitor. Low voltage on the -25V on one or two phases could indicate a defective stepper motor.

Waveshape, as well as amplitude, can be an indication of a problem.

Scope setup: All pictures taken with a times 10 probe. Voltage: 2V/Div; Time: 1MS/Div; Trigger: Internal plus DC Input; Chan 1: Motor Drive Pulse (measured at P-4 connector).

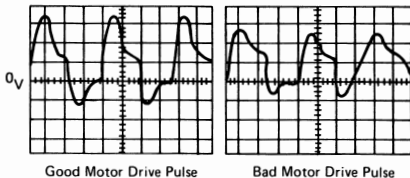

C3 and C4 are located at the rear behind the electronics gate, or on the right side frame. C3 and C4 are 3 mfd. See diagram 8-19 in the MLTG for motor drive circuit.

**Figure 7-15. Print Belt Motor Drive Pulses**

**Failure of Typebelt Startup, Wear at Bottom Edge of Typebelt, Noisy Idle, Ribbon Damage or Jam, Smudge Print, Drop Ready, or Some Positions Fail to Print or Overprint**

These are some of the problems caused when the typebelt drive or idler pulleys are not free to float up and down. When running, these pulleys should not be at their upper or lower limit. When not running the pulleys must freely move up and down. A quick check of pulleys binding is to observe pulleys as the typebelt tension is removed. Both idler and drive pulleys should drop. If pulleys do not drop, or are in a "top out" or "bottom out," investigate the following areas:

1. Binds in pulley movement. (Pulleys should move up freely with light finger pressure and drop back down, the first and every time they are tested.)
  - a. Pulley cage spring wrapped into bearing cage: replace with spring PN 1794866.
  - b. Bearing cage retainer rings with too small inside diameter: replace bearing retainers PN 1801941.
  - c. Flat spot on pulley shaft: replace motor or idler shaft.
2. Misaligned idler shaft (pulley "top out").

If the free-floating pulley rides up too high and comes in contact with the cover (the name given to the part on top of the pulley that has the finger holes in it), the belt must go down to achieve an equilibrium point. When the belt drives down, it puts excessive force on the two front bearings, causing wear and binds. An adjustable clevis can be installed if this is the problem. Order PN 1812463 clevis, PN 1794808 eccentric, PN 1794809 pin, and PN 0186929 screw, or order ECA 017.

3. Pulley bearing cage being held too high.

Incorrect 1/2-inch spring used before 4/77; replace with 1/4-inch spring PN 1794866.

4. Drive pulley "bottom out."

Many 3288 printers shipped to date have the drive pulley very close to a "bottom out" condition where float downward is severely restricted. Some machines may have been shipped where no downward float exists.

Two specific situations arise because of this condition:

- Belt may rise off the left-hand guide roll.
- Belt may be forced downward.

Shims are required to achieve a float condition of the drive pulley. Put enough shims as required, that result in an equal amount of upward and downward movement from the float position.

The shims are to be placed between the front assembly casting and the right-hand side of the print belt drive motor mounting plate, as follows:

- a. Loosen the two left-hand motor mounting screws.
- b. Remove the right-hand motor mounting screw.
- c. Raise the right side of the motor, install the shims, and put the right-hand screw through the shims.
- d. Tighten all three motor mounting screws.

The following may be used:

- .004 shim PN 104371
- .006 shim PN 45664

Because of the interaction, the right-hand idler pulley float should also be checked for equal amount of upward and downward movement from the float position. To verify, hold the outside rim of the pulley at opposite sides and lift. The pulley should move up and down freely.

## Type Belt Part Numbers

USA English	EBCDIC	PN 1795184
Belgium/France	EBCDIC	PN 1795184
Italy	EBCDIC	PN 1795184
Austria/Germany	EBCDIC	PN 1795188
Nor/Den	EBCDIC	PN 1795189
Swed/Fin	EBCDIC	PN 1795190
Spanish-Speaking	EBCDIC	PN 1795191
UK	EBCDIC	PN 1795192
Portuguese-Speaking	EBCDIC	PN 1795193
ASCII-A		PN 1795194
ASCII-B		PN 1795195
Katakana - 128-Char. Set	EBCDIC	PN 1795200
Text Print 120-Char. Set USA English		PN 1795224

## Installation of Ribbon Cassette

- Power must be off when a new ribbon is being installed. Dropping power de-energizes the ribbon drive clutch solenoid, allowing the ribbon to move when turning the idler wheel.

## Ribbon Jamming or Feeding Problems

- Excessive use of ribbons can be caused by worn ribbon drive rolls.

When ribbon rolls are being replaced, all six rolls must be replaced at the same time.

After replacing the rolls, the CE should loc-tite the screw holding the driven stack of rollers. This screw has a tendency to back out.

The CE should also make sure the torsion spring on the ribbon pressure handle is replaced with the loop towards the rear of the machine. With it on backwards, insufficient pressure is put on the drive roll.

- A new ribbon drive unit, PN 1794829, is available to improve ribbon feeding. The idler bracket, PN 1794954, is a new field replaceable unit within the drive unit. If the drive rolls are worn on the new ribbon drive unit, replace three drive rolls, PN 1794953, and the idler bracket, PN 1794954. New rolls are *not* black.
- Ribbon jams can be caused by the right end of the cassette being mounted incorrectly. A cassette interlock bracket is released to prevent this problem. Order PN 1794941.
- If you are having ribbon tracking problems the new style ribbon guides are adjustable. Order the new style part numbers shown in Figure 7-16.

## Text Print Feature

- There are two cards in the Text Print Feature, A1C2 PN 8528263 and A1D2 PN 8528264. Also, the 01A-A1 board PN 1657198 must be at EC 742879 or higher. Use of the EBCDIC belt allows printing the 64-character set. Use of the Text Print Belt allows printing the 120-character set.

## CE Test for Text Print Feature

- If every third line overprints on CE test, the Text Print Feature is installed. Overprinting is caused by the index suppress function (normal). To overcome the index suppress function, jumper C2U13 to DC return (GND). See Diagrams A4 and E1 in the MLTG. Remove the jumper after test.

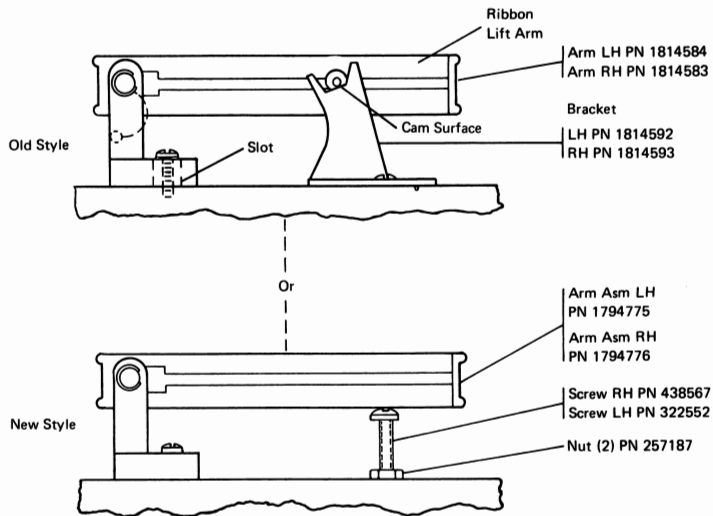

Figure 7-16. Ribbon Lift Arm Assemblies (Old and New Styles)

## Section 8. Synchronous Data Link Control (SDLC)

### Contents

<b>Problem Development Procedures</b> . . . . .	8-3
<b>Problem Repair Procedures</b> . . . . .	8-5
Card Replacement . . . . .	8-5
Preliminary Checks . . . . .	8-6
<b>3270 SDLC Cards</b> . . . . .	8-6
<b>Block Diagram, Data Flow, Card Layouts, Message Formats, Status and Sense, and Sequences and Responses</b> . . . . .	8-6

### Figures

Figure 8-1.	Card Replacement Chart . . . . .	8-5
Figure 8-2.	3271 Models 11 and 12 CU Functional Block Diagram . . . . .	8-7
Figure 8-3.	3275 Models 11 and 12 Remote Interface and Control Unit Data Flow — EBCDIC . . . . .	8-8
Figure 8-4.	3271 Model 11 and 12 Board Layout and Card Locations — A-Gate . . . . .	8-9
Figure 8-5.	3275 Model 11 and 12 Card Layout by Function — B-Gate . . . . .	8-10
Figure 8-6.	I-Format, Data Message (3 parts) . . . . .	8-11
Figure 8-7.	Sense/Status Message Format . . . . .	8-14
Figure 8-8.	Command Reject (CMDR) Message Format . . . . .	8-15
Figure 8-9.	Non-Sequenced Message Format . . . . .	8-16
Figure 8-10.	Supervisory Message Format . . . . .	8-16
Figure 8-11.	Command Reject Status Bytes . . . . .	8-17
Figure 8-12.	Request and Response Format . . . . .	8-18
Figure 8-13.	Remote Status and Sense Byte Definition (2 parts) . . . . .	8-19
Figure 8-14.	Remote Error Status and Sense Responses and Requests (2 parts) . . . . .	8-21
Figure 8-15.	Remote Status and Sense Conditions . . . . .	8-23
Figure 8-16.	Device Addressing for 3271 Control Unit Models 11 and 12 . . . . .	8-23
Figure 8-17.	Online and Offline Sequence/Response Diagram . . . . .	8-24
Figure 8-18.	SDLC Read Type Command Sequence/Response Diagram . . . . .	8-25
Figure 8-19.	SDLC Write Type Command Sequence/Response Diagram . . . . .	8-26



## Section 8. Synchronous Data Link Control (SDLC)

### PROBLEM DEVELOPMENT PROCEDURES

The following procedures provide information on how to diagnose and repair problems that occur intermittently. Prior to performing the procedures, Fast Test and Online Tests should be run several times to gather as many symptoms of the problem as is possible. The following procedures assumes that the Fault-Finding Tape Tests and Error Codes did not provide a repair.

If you are not sure of a YES or NO decision, assume the decision to be NO. If a YES decision does not provide a repair, go to the NO decision to continue.

1. Is there more than one device failing?

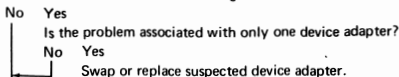

2. Can the problem device(s) be swapped with a non-failing device?

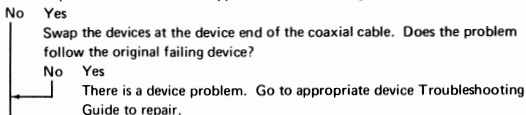

3. Is there wrong data on the display screen or in the printout?

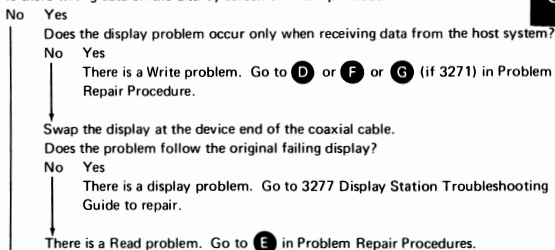

4. Does the 3270 system detect the problem (Status)?

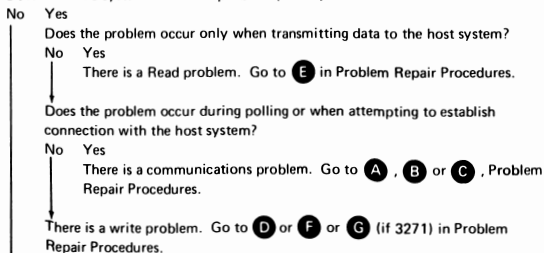

A

5. Does the host system detect the problem?

No Yes

One of the following problems exists:

- A communications problem. Go to **A**, **B**, or **C** in Problem Repair Procedures.
- A telephone line or equipment problem.

6. Does problem occur at a specific time of day?

No Yes

The problem might be associated with one of the following:

- Power Company power.
- Customer equipment such as:
  - Elevators
  - Business machines
  - Radio frequency (RF) interference
- Telephone line crosstalk (especially at midday).

7. Did the 3270 system ever operate correctly?

No Yes

The problem might be associated with one or more of the following:

- New customer job application (host system problem).
- Recent modification at the host system.
- Recent EC or MES on 3270 system.

8. Are there any other symptoms of the problem?

No Yes

Go back to the beginning of these Problem Development Procedures and look for the symptom that most closely matches the problem.

9. Do any of the following conditions exist?

- No symptoms.
- No procedures left to try.
- Too intermittent.
- Problem appears to be external to 3270 system; however Modem, TP line and host system initial checks have not revealed the problem.

No Yes

Call for assistance. Assistance will be required to provide:

- A data stream analysis (using data trapping equipment and traces).
- The latest Symptom/Fix information.
- Repairs for problems external to the 3270 system.

A symptom of the problem has been overlooked. Start at the beginning of the Problem Development Procedures.

## PROBLEM REPAIR PROCEDURES

### Card Replacement

Before replacing any of the cards in Figure 8-1, do the preliminary checks following the chart.

Problem	Intermittent Problem Description	Unit Type	Card Replacement
A	Fails to communicate with host system at any time (Solid Timeout)	3271	A2-K2, A2-G2, A2-E2, A2-C4, A2-H2, A2-J2, A1-J2, A2-D2, A2-F2, A2-L2
		3275	B-K2, B-G2, B-E2, B-N2, B-H2, B-J2, A-G2, B-M2, B-F2, B-L2
B	Fails during communication of line control; might be Timeout (Not reads or writes)	3271	A2-K2, A2-G2, A2-H2, A2-J2, A2-D2, A2-E2
		3275	B-K2, B-G2, B-H2, B-J2, B-D2, B-E2
C	Fails during communication due to unexpected status from attached device(s).	3271	A1-B2, A1-C2, A2-F2, A2-G2, A2-E2, A2-K2, A1-K2, A1-F2, A1-L2, A1-J2, A1-P2, A2-J2, A2-D2, A1-N2, A1-H2, A2-H2, A1-M2, Device Adapter
	Fails during communication due to unexpected status.	3275	B-E2, B-G2, A-D2, A-F2, A-C2, B-F2, A-G2, A-E2, B-K2, B-J2, B-H2
D	Fails to write data correctly to device.	3271	A2-J2, A2-H2, A2-D2, A2-C4, A2-L2, A2-G2, A1-G2, A1-F2, A1-D2, A1-M2, A2-E2, A1-H2, A1-P2, A1-J2, A1-B2, A1-C2, A1-K2, Device Adapter, Buffer
	Fails to write data correctly (assume display works correctly).	3275	B-J2, B-H2, B-M2, B-N2, B-L2, B-G2, B-D2, B-B2, B-C2, A-E2, A-G2, A-C2, A-D2, A-F2
E	Fails to read data correctly from device.	3271	A2-E2, A2-J2, A2-D2, A2-C4, A2-L2, A2-G2, A1-E2, A1-F2, A1-P2, A1-D2, A1-C2, A1-K2, A1-B2, A1-G2, A1-J2, A1-H2, A1-M2, Device Adapter
	Fails to read data correctly.	3275	B-M2, B-N2, B-L2, B-G2, B-D2, B-A2, B-C2, A-E2, A-G2, A-C2, A-D2, A-F2
F	Fails to execute Orders correctly.	3271	A1-F2, A-D2, A1-K2, A1-N2, A2-D2, A1-H2, A1-E2
		3275	B-B2, B-C2, B-D2, A-E2, B-J2, B-M2
G	Fails on Copy command.	3271	A-C2, A1-H2, A1-J2, A1-K2, A1-P2, A1-N2

Figure 8-1. Card Replacement Chart

## Preliminary Checks

Before replacing any cards, do the following:

1. Check voltage ripple levels (below) and tighten all power supply capacitor screws.

Power Supply	Voltage	Regulation	Ripple	Pin Number	
				3271	3275
TSR	+5V dc	±8%	±8%	A2-K2D03	B-K2D03
TSR	+8.5V dc	±8%	±8%	A2-K2D11	B-K2D11
TSR	-5V dc	±8%	±8%	A2-L2D06	B-L2D06
Standard	+5V dc	±10%	.25V	A2-D2D03	B-D2D03
	+34V dc	±10%	1.0V	Not used	A-M2D11
	+8V dc	±12%	.35V	Not used	Voltage Dis- tribution Board
	-12V dc	±4%	.01V	A2-K2D06	

2. Inspect cables for visible damage.
3. Check for loose or poorly seated cards and cables.
4. Inspect signal and frame ground for tight connections.

Cards in each problem group are listed with the most likely problem listed first and the least likely last (left to right, top to bottom). It is recommended that two to five cards are swapped or replaced at a time (depending upon problem rate of occurrence).

## 3270 SDLC CARDS

3271	3275	Card PN	3271	3275	Card PN
01A-A2E2	01B-A1E2	8527912	01A-A2J2	01B-A1J2	8527910
		8527990			8527989
		8563024			8527993
		<u>8564136</u>			8563036
01A-A2F2	01B-A1F2	8527909	01A-A2K2	01B-A1K2	8564131
		8563025			8564139
		8563038			<u>8564140</u>
		8563040			<u>8527914</u>
		<u>8564147</u>			<u>8527908</u>
01A-A2G2	01B-A1G2	8527911	01A-A2D2	01B-A1M2 (EBCDIC)	<u>8527897</u>
01A-A2H2	01B-A1H2	8527311	01A-A2D2	01B-A1M2 (ASCII)	<u>8527899</u>
		8527994			
		8563037			
		<u>8564138</u>	01A-A2C4	01B-A1N2	<u>8526685</u>

*Note:* Underlined cards are the latest level.

## BLOCK DIAGRAM, DATA FLOW, CARD LAYOUTS, MESSAGE FORMATS, STATUS AND SENSE, AND SEQUENCES AND RESPONSES

See Figures 8-2 through 8-19.

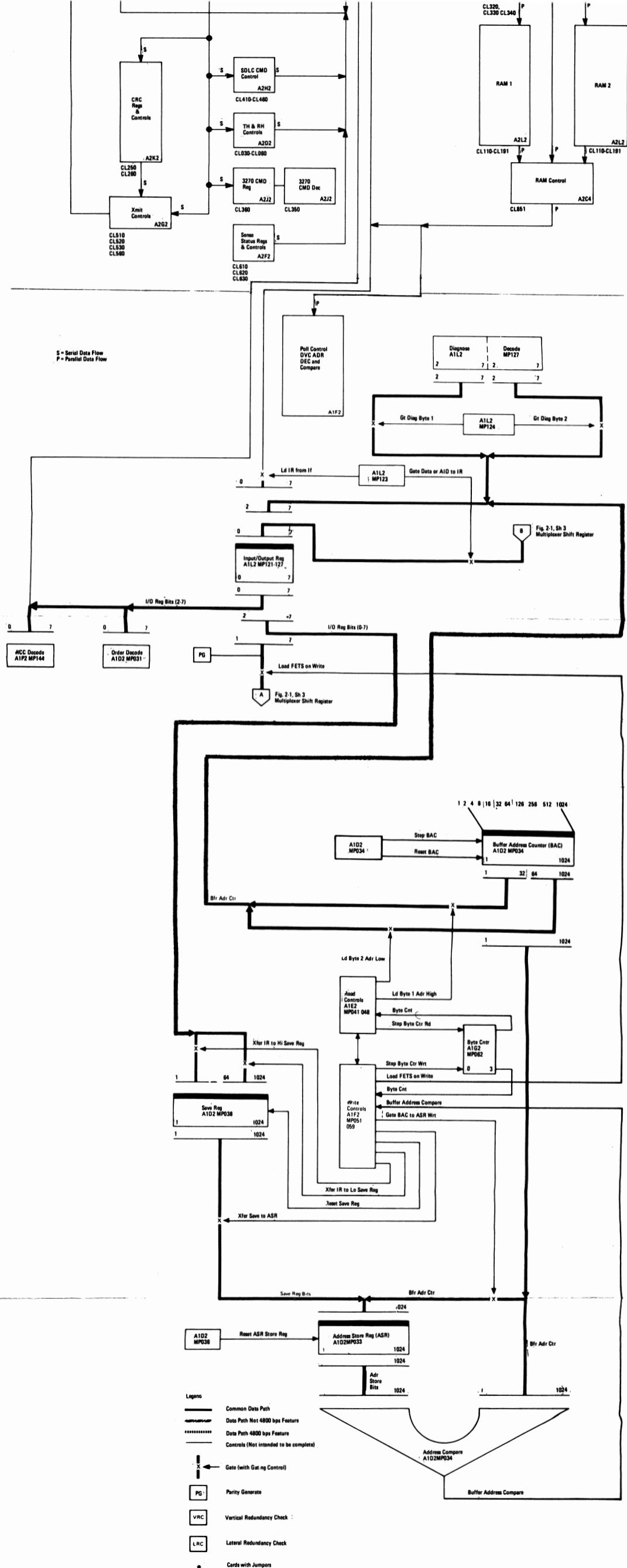
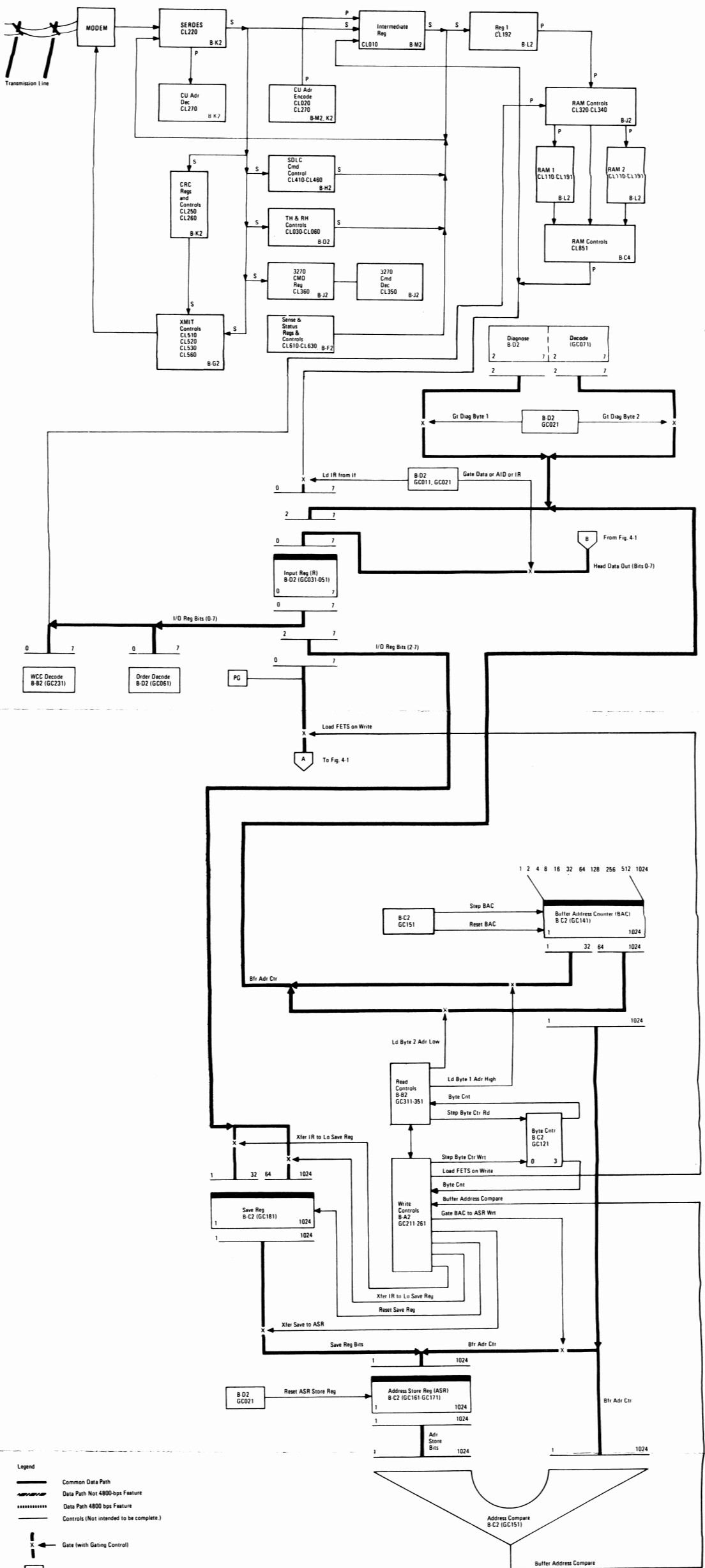

Figure 8-2. 3271 Model 11 and 12 CU Functional Block Diagram



- Legend**
- Common Data Path
  - Data Path Not 4800-bps Feature
  - Data Path 4800-bps Feature
  - Controls (Not intended to be complete.)
  - Gate (with Gating Control)
  - Parity Generate
  - Vertical Redundancy Check
  - Lateral Redundancy Check
  - Cards with Jumpers

1 On Display Stations with Integrated Modem feature installed, "Data Set" consists of cards B-N2 and B-N4.  
 S = Serial Data flow.  
 P = Parallel data flow.

Figure 2-2. 3275 Model 11 and 12 Remote Interface and Control Unit Data

**BOARD A1 (PIN SIDE)**

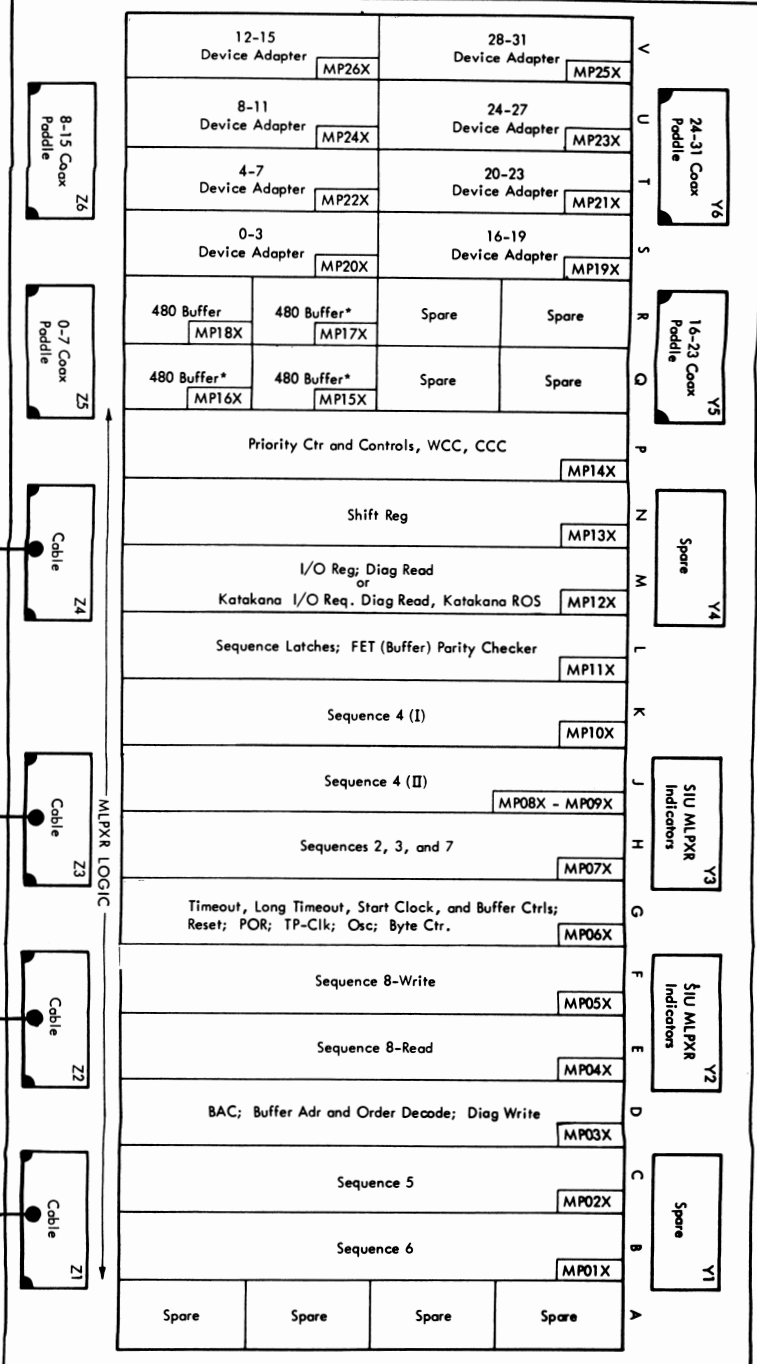

- Notes:
1. Number in parentheses is card type.
  2. MP = MPXR (multiplexer) ALDs.
  3. CL = Remote Interface ALDs.

Example: MP 16X = MP160 through MP169

**BOARD A2 (CARD SIDE)**

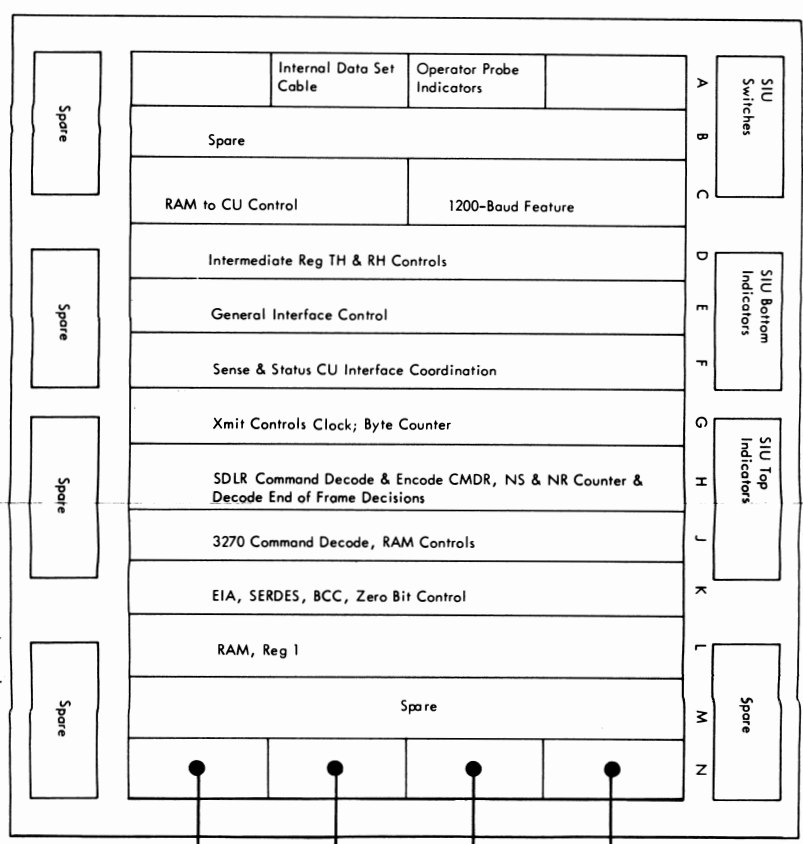

Legend:



**Figure 8-4. 3271 Model 11 and 12 Board Layout and Card Locations — A-Gate**

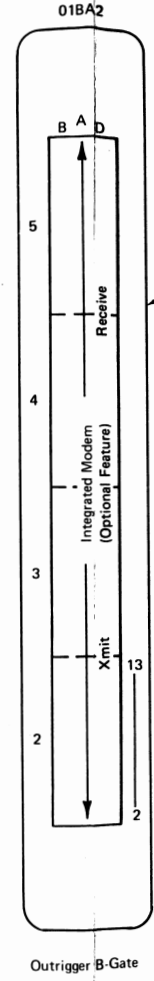
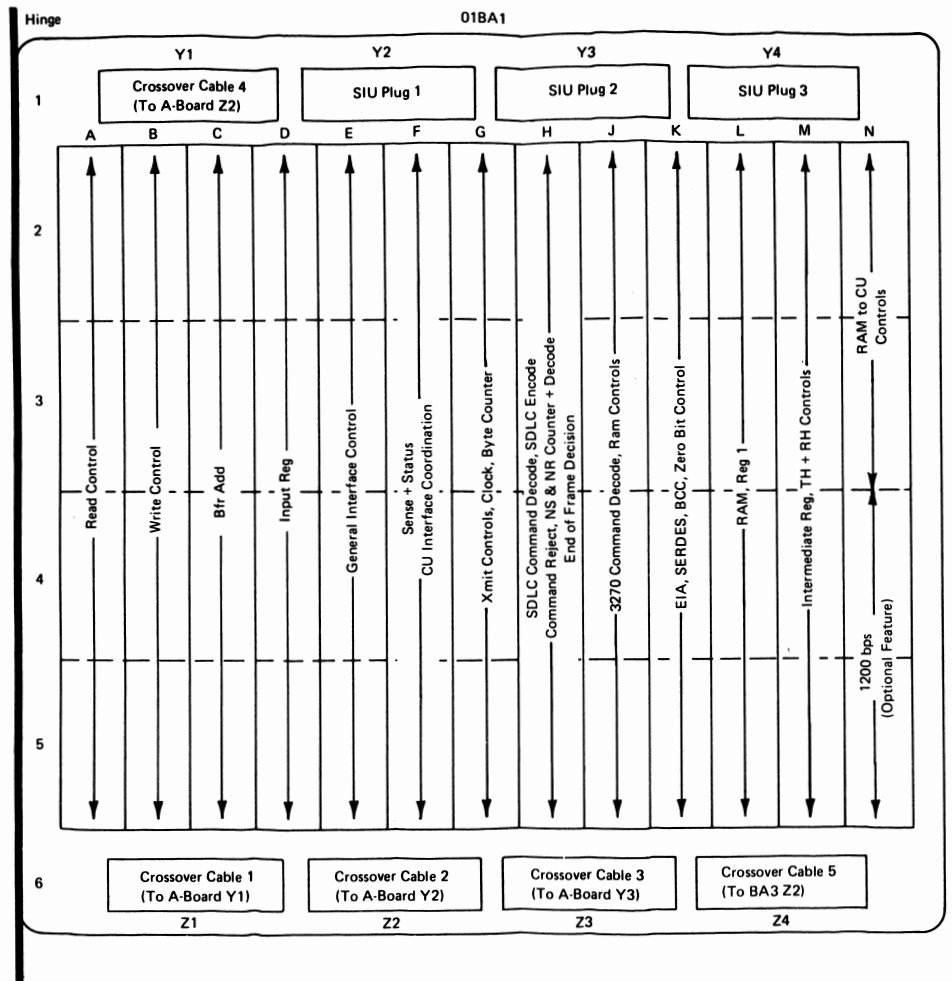

Connection blocks shown from pin side.

Note: When Integrated Modem feature is not installed, crossover cable 5 is removed and BA1Z4 is used for I/O and indicators.

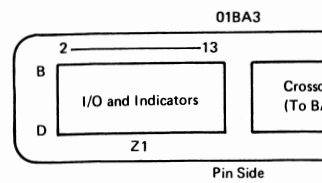

Figure 8-5. 3275 Model 11 and 12 Card Layout by Function – B-Gate

SDLC Frame Format

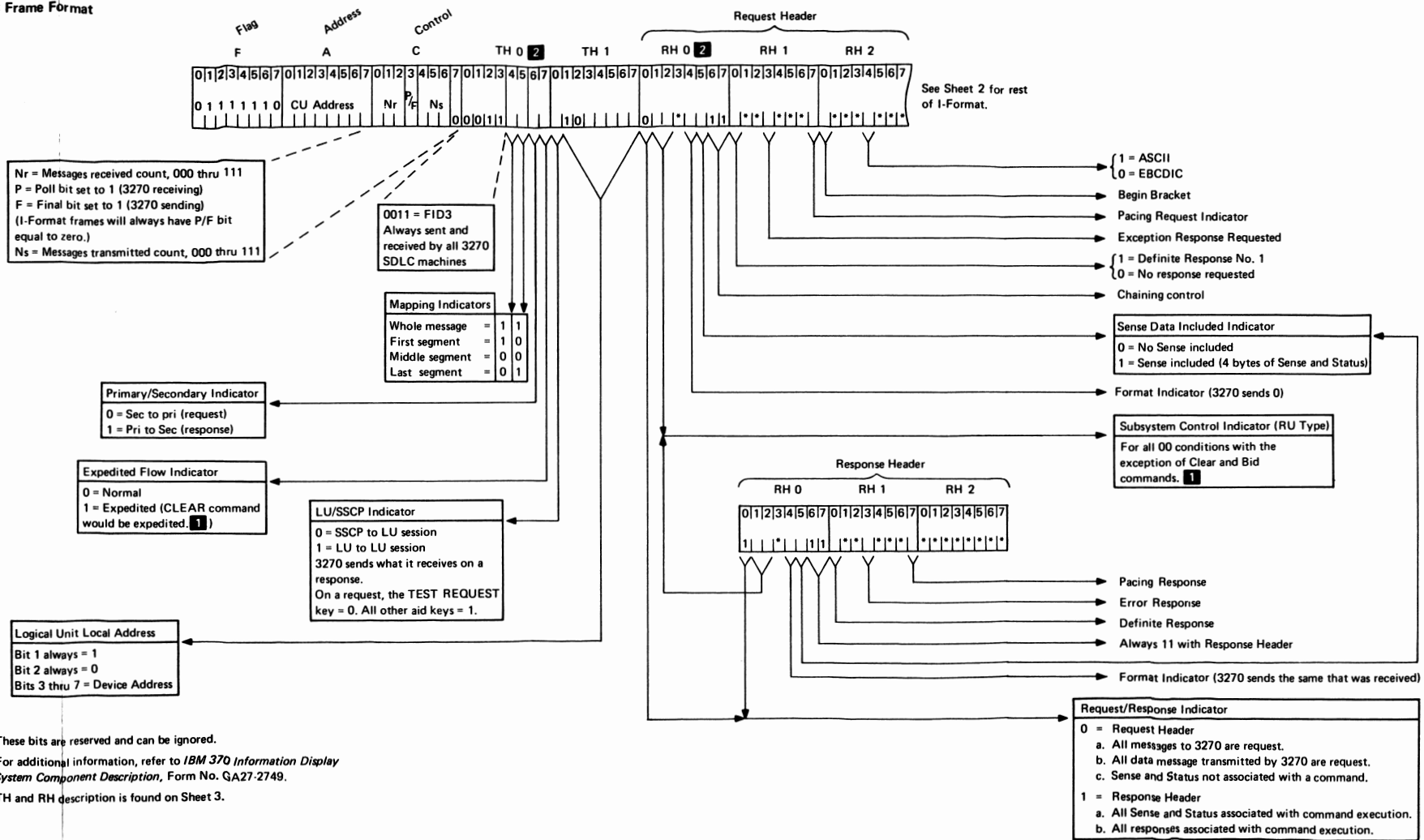
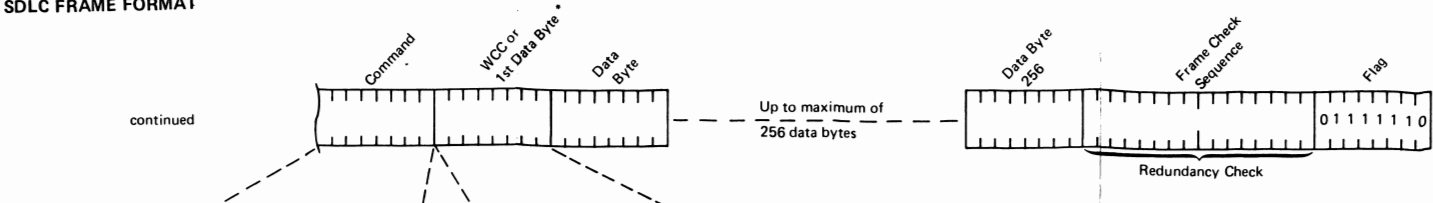

Figure 8-6 (Part 1 of 3). I-Format, Data Message

SDLC FRAME FORMAT



Remote Command Codes

Command	EBCDIC Hex	EBCDIC or ASCII Graphic	ASCII Hex
Write	F1	1	31
Erase/Write	F5	5	35
Read Buffer	F2	2	32
Read Modified	F6	6	36
Copy	F7	7	37
Erase All Unprotected	6F	?	3F

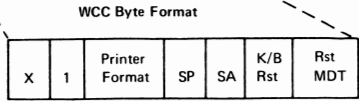

- EBCDIC Bits 0 1 2 3 4 5 6 7
- Bit 0 - Determined by bits 2-7. (See Table 1.)
  - Bit 1 - Always set.
  - Bits 2 and 3 - Define printer format as follows:
    - 00 - New line (NL) and end of message (EM) honored.
    - 01 - 40-character line length.
    - 10 - 64-character line length.
    - 11 - 80-character line length.
  - Bit 4 - Start printer, when set, initiates a printout operation. Bit 4 should be set only when the Write command containing the WCC is not chained to a subsequent command, or that command will be aborted.
  - Bit 5 - Sound alarm, when set, sounds the audible alarm if the Write command is addressed to a display station with the Audible Alarm feature.
  - Bit 6 - Keyboard restore, when set, restores the keyboard and resets the AID byte at the termination of the Write command.
  - Bit 7 - Reset modified data tag (MDT), when set, resets all MDT bits to 0 before the Write command is performed. MDT bits may be set by the write data stream.

\* This byte is a Write Control Character (WCC) only for Write commands. For any other command, it is the first data byte.

Table 1. Assignments for Internal 6-Bit Structured Data

Bits 2-7	Graphic	EBCDIC	ASCII
00 0000	SP	40	20
00 0001	A	C1	41
00 0010	B	C2	42
00 0011	C	C3	43
00 0100	D	C4	44
00 0101	E	C5	45
00 0110	F	C6	46
00 0111	G	C7	47
00 1000	H	C8	48
00 1001	I	C9	49
00 1010	␣,.,!	4A	5B
00 1011	.	4B	2E
00 1100	<	4C	3C
00 1101	(	4D	28
00 1110	+	4E	2B
00 1111	!,!,!	4F	21
01 0000	&	50	26
01 0001	J	D1	4A
01 0010	K	D2	4B
01 0011	L	D3	4C
01 0100	M	D4	4D
01 0101	N	D5	4E
01 0110	O	D6	4F
01 0111	P	D7	50
01 1000	Q	D8	51
01 1001	R	D9	52
01 1010	!,.,!	5A	5D
01 1011	\$	5B	24
01 1100	*	5C	2A
01 1101	)	5D	29
01 1110	:	5E	3B
01 1111	␣,.,! ^	5F	5E
10 0000	-	60	2D
10 0001	/	61	2F
10 0010	S	E2	53
10 0011	T	E3	54
10 0100	U	E4	55
10 0101	V	E5	56
10 0110	W	E6	57

Bits 2-7	Graphic	EBCDIC	ASCII
10 0111	X	E7	58
10 1000	Y	E8	59
10 1001	Z	E9	5A
10 1010	␣,.,! \	6A	5C
10 1011	.	6B	2C
10 1100	%	6C	25
10 1101	-	6D	5F
10 1110	>	6E	3E
10 1111	?	6F	3F
11 0000	0	F0	30
11 0001	1	F1	31
11 0010	2	F2	32
11 0011	3	F3	33
11 0100	4	F4	34
11 0101	5	F5	35
11 0110	6	F6	36
11 0111	7	F7	37
11 1000	8	F8	38
11 1001	9	F9	39
11 1010	:	7A	3A
11 1011	=	7B	23
11 1100	@	7C	40
11 1101	'	7D	27
11 1110	=	7E	3D
11 1111	"	7F	22

The following characters are internally handled as 6-bit structured data: write control, copy control, attribute, CU and device address, buffer address, and status and sense. When any of these characters is received, only the low-order 6 bits are used, and the rest are ignored. When any of these characters is transmitted, the appropriate EBCDIC code is assigned, and, if the ASCII Code Transmission feature is installed, an ASCII code translation is made. The EBCDIC code assignment is done so that the 6-bit code can be represented by a graphic character. Note that this table is an overlay of EBCDIC columns 4-7 hex on EBCDIC columns C-F hex.

Figure 8-6 (Part 2 of 3). I-Format, Data Message

**TRANSMISSION HEADER (TH)**

Byte	Bit	
0	0, 1, 2, 3	Format identifier field – This configuration of FID bits defines the number of transmission headers (TH) and request/response headers (RH) required. 3270 sends FID 3 (0011)
0	4, 5	11 – Indicates a complete basic information unit (BIU); i.e. the I-field associated with the TH is a complete unit. 10 – Indicates that the I-field associated with the TH is the first I-field in the BIU. 01 – Indicates that the I-field associated with the TH is the last I-field in the BIU. 00 – Indicates that the I-field associated with the TH is an intermediate I-field within the BIU.
0	6	Flow indicator – Sent as a 1 when the 3270 CU sends a response. Sent as a 0 when the 3270 CU sends a request.
0	7	Expedited flow indicator – Sent as a 0 in all cases except when sending a clear response.
1	0	Logical unit/system services control point – 3270 stores this bit when received from the controller. When sending a response to the controller in reply to a request, the 3270 returns this bit as it was received.
1	1, 2, 3, 4, 5, 6, 7	Device address – Bit 1 is always set to 1. Device address 0 is used when communicating with 3275 display station.

**REQUEST/RESPONSE HEADER (RH)**

Byte	Bit	
0	0	Request/response bit – The 3270 CU sends the RR bit to the controller as a 0 to indicate a request. It is sent by the 3270 CU as a 1 to indicate a response.
0	1, 2	Request/response unit type and subsystem control indicator bits respectively. They are stored but not checked.
0	3	Not used (always 0).
0	4	Format indicator – When the 3270 CU generates a request, the format indicator bit is sent as a 0. When sending a response, the 3270 sends this bit as it was received from the controller.
0	5	Sense data included indicator – The 3270 sends this bit as a 1 when sense data is transmitted, and as a 0 when sense information is not sent to the controller.
0	6, 7	Not used by the 3270 (always 1)
1	1, 2, 4, 5, 6	Not used by the 3270 (always 0)
1	0	Direct response – Indicates to the 3270 CU that a response must be sent when the specified command operation has been completed.
1	3	Exception response – An EX response is generated by the 3270 CU if an error condition (other than an SDLC error) is detected while executing a command.
1	7	Pacing control – Pacing is a response which allows the 3270 CU to indicate to the controller when message data can be sent for a device. Used when executing a command at a printer; at this time, pacing control is also used when performing a command operation at a display station.
2	0	Begin bracket – Used by the 3270 CU in conjunction with the Pseudo bid command. Decrements the poll counter in the 3270 CU.
2	1	End bracket – Indicates that the current chain is the last chain in a bracket.
2	2, 3, 5, 6, 7	Not used (always 0)
2	4	Code selection indicator – This bit identifies the transmission code as EBCDIC (0), or ASCII (1).

**Figure 8-6 (Part 3 of 3). I-Format, Data Message**

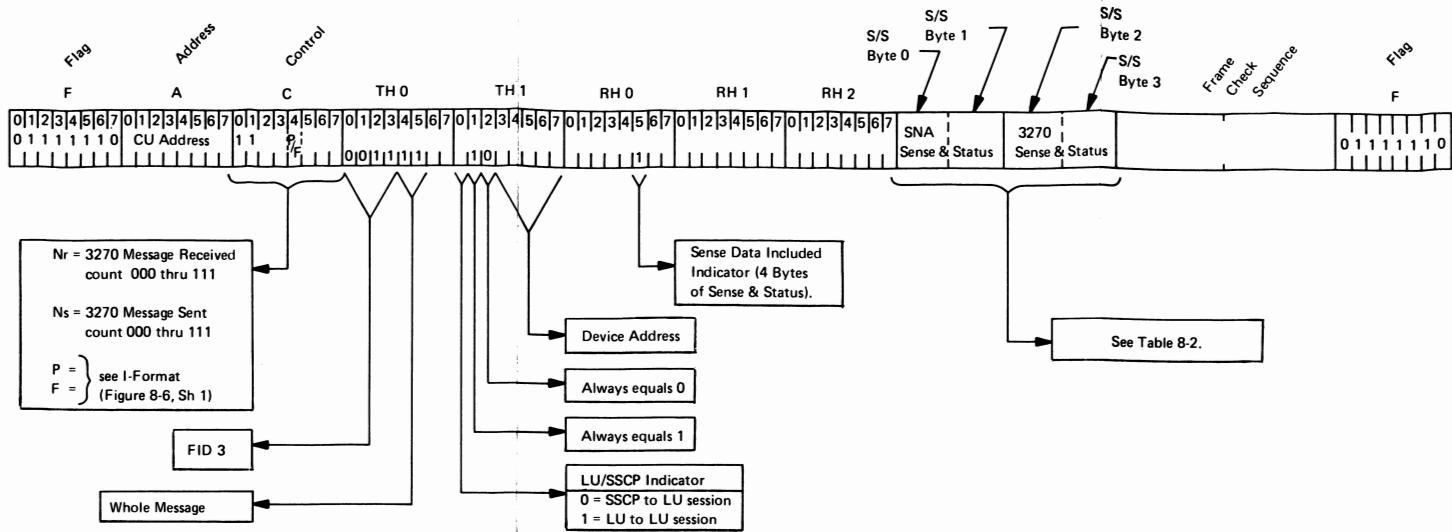

Note: This chart is intended to show those bits that must be on for a S/S message. For all other bits, see I-Format, Figure 8-6, Sheets 1 and 2.

Figure 8-7. Sense/Status Message Format

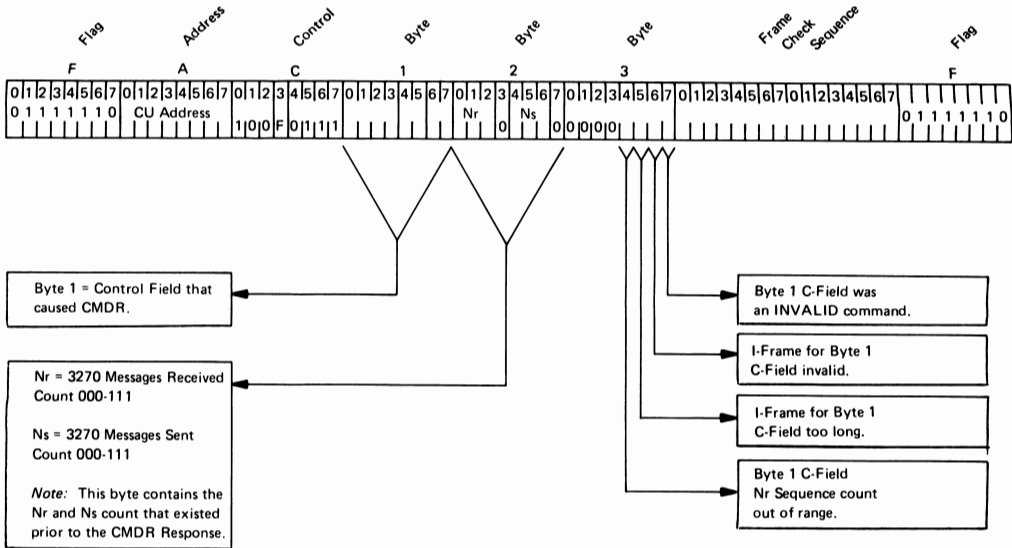
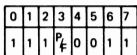
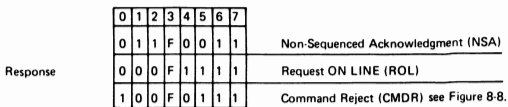
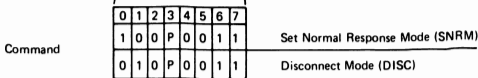
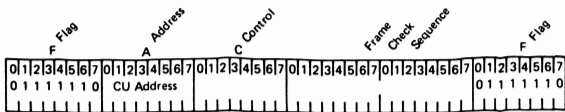
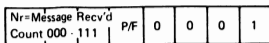
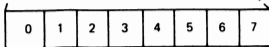
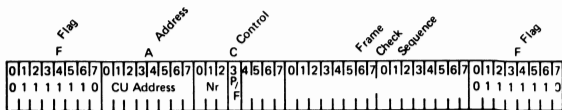

Figure 8-8. Command Reject (CMDR) Message Format



Link Test: When received by 3270, will be sent by 3270 in response.

Figure 8-9. Non-Sequenced Message Format



Receiver Ready (RR)

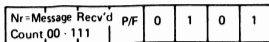

Receiver Not Ready (RNR)

Figure 8-10. Supervisory Message Format

The Command Reject (CMDR) response is sent by the 3270 CU to report the following error conditions:

1. Receipt of a command code with valid BCC but which is an invalid command or a command not implemented for the 3270 CU.
2. Receipt of a frame with valid BCC that contains an I-field and a command which should not be sent with an I-field.
3. Receipt of an I-format frame with valid BCC which contains an illegal Nr count in the C-field.
4. Receipt of an I-format frame in which the information field is too large to be accommodated by the available buffer space in the 3270 CU.

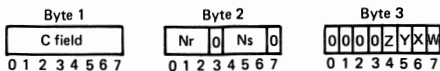

Byte 1 is the C-field that caused the CMDR response.

Byte 2 contains the Ns and Nr sequence counts that existed immediately prior to establishing the CMDR response.

Byte 3 indicates the reason for the CMDR.

Bit W is set to 1 when the C-field returned in byte 1 represents an invalid or non-implemented command.

Bit X is set to 1 when the C-field returned in byte 1 is considered invalid because the frame contained an information field not allowed with the command sent.

Bit Y is set to 1 when the information field associated with the valid and implemented C-field contained in byte 1 was too long for the available buffer space in the 3270 CU. This condition never occurs when bit X is set.

Bit Z is set when the receive Nr sequence count contained in the C-field in byte 1 is out of the range.

**Figure 8-11. Command Reject Status Bytes**

Response	Request format— sent by the controller:			Response format— sent in reply by the 3270 CU:			Explanation
	DR	EX	P	DR	EX	P	
Definite response with pacing	1	0	1	1	0	1	<p>Indicates successful completion of a read or write type or copy command by a display station; or a write type or copy command by a printer.</p> <ol style="list-style-type: none"> <li>Indicates that an error occurred during transmission of read data. In this case, the response may be preceded by a sense RU request containing an abort indication.</li> <li>Indicates that an error was detected while obtaining a device buffer.</li> </ol> <p><i>Note: The printer operates in positive response with pacing mode only. Therefore, when a command has been executed by a printer the 3270 CU always responds with positive response with pacing (101 or 111) regardless of the request received.</i></p>
				1	1	1	
Exception response with pacing	1	1	1	0	0	1	<p>Indicates successful completion of a read or write type or copy command by a display station.</p> <ol style="list-style-type: none"> <li>Indicates that an error was detected while obtaining a device buffer.</li> <li>Indicates that an error occurred during transmission of read data. In this case a sense RU request with an abort segment indication is transmitted before the response.</li> </ol>
				1	1	1	
No response with pacing	0	0	1	0	0	1	Applicable to commands executed by display stations only. An error response (EX = 1) is not sent regardless of how the operation ends. The 3270 CU transmits only an isolated pacing response.
Definite response no pacing	1	0	0	1	0	0	Applicable to display station command operations only. The response description is the same as described above for positive response with pacing, except that the pacing bit is always set to 0.
Exception response, no pacing	1	1	0	0	0	0*	Applicable to display station command operations only. The response format is the same as explained above for exception response with pacing, except that the pacing bit is always set to 0.
No response no pacing	0	0	0	0	0	0*	Applicable to display station command operations only. The 3270 CU does not send a response.

\*A response format 000 indicates that no response is sent.

Figure 8-12. Request and Response Format

Bit No.	Bit Definition
	S/S Byte 0:
0	<i>Path Error</i> – For the 3271, this bit is set if the device address received (bits 1 through 7 of TH byte 2) is invalid, or if the device adapter card for the indicated address is not installed.  For the 3275, this bit is set if the device address is not 100000 (bits 1 through 7 of TH byte 2).  Intervention Required (IR), S/S byte 3, bit 3, may also be set with this bit.
1,2	Reserved
3	<i>Request Error</i> – This bit is set if the first byte of the RU is not recognized as a valid command or command function. Command Reject (CR), S/S byte 3, bit 2, is set when Request Error is set.
4	<i>Request Reject</i> – The bit is set if a pseudo bid command or begin bracket bit (set in the RH) is sent to a device that has an attention pending.
5,6,7	Reserved.

Bit No.	Bit Definition
	S/S Byte 1:
0,1,2,4,5	Reserved.
3,6,7	These bits are set with <i>request reject</i> (bit 4, byte 0)
	S/S Byte 2:
0,1,2,3	Reserved.
4	<i>Device Busy (DB)</i> – This bit indicates that the addressed device is busy executing an operation. The device is busy when executing an erase all unprotected command, or a print operation, accepting data from the Operator Identification Card Reader, or performing various keyboard operations (Erase Input, Backtab and Clear).
5	<i>Unit Specify (US)</i> – This bit is set if any S/S bit is set as a result of a device-detected error.
6	<i>Device End (DE)</i> – This bit indicates that the addressed device has changed from unavailable to available and not ready to ready, or busy to not busy. When a printer goes from busy to not busy, a positive response with pacing is generated instead of DE.
7	Reserved.

Figure 8-13 (Part 1 of 2). Remote Status and Sense Byte Definition

Bit No.	Bit Definition
	<p>S/S Byte 3:</p>
0,1	Reserved.
2	<p><i>Command Reject (CR)</i> – This bit is set upon receipt of an invalid or illegal 3270 command.</p>
3	<p><i>Intervention Required (IR)</i> – This bit is set if:</p> <ul style="list-style-type: none"> <li>• A copy command contains a "from" device address in its data stream which specifies an unavailable device.</li> <li>• A command attempted to start a printer but found it not ready. The printout is suppressed.</li> <li>• The 3271 receives a Pseudo Bid sequence for a device which is unavailable or which became not ready during a printout.</li> <li>• The 3270 CU receives a command for a device which the 3271 has logged as unavailable and not ready.</li> </ul>
4	<p><i>Equipment Check (EC)</i> – This bit is set if:</p> <ul style="list-style-type: none"> <li>• A printer character generator error occurred, or the printer became mechanically disabled.</li> <li>• The 3270 CU detected bad parity from the device, or data transmitted in a device reply.</li> </ul> <p><i>Note: The data check (DC) bit may also be set.</i></p>
5	<p><i>Data Check (DC)</i> – This bit indicates detection of a parity or cursor check in either the 3271 or a device buffer, or in the 3275 buffer, or that the 3271 detected bad parity from the device.</p>
6	<p><i>Control Check (CC)</i> – This bit is not used for the 3275. For the 3271, this bit indicates a timeout check. A timeout check occurs when a device fails to respond to 3271 communications within a specified time period or when a device fails to complete an operation within a specified time period.</p>
7	<p><i>Operation Check (OC)</i> – This bit, when set alone, indicates one of the following:</p> <ul style="list-style-type: none"> <li>• Receipt of an illegal buffer address or of an incomplete order sequence on a write or erase/write command.</li> <li>• The device did not receive a CCC or a "from" address on a copy command.</li> <li>• Receipt of a read, read modified, copy, or erase all unprotected command with TH mapping field bits not equal to 11 (i.e., a complete BIU).</li> <li>• An I/O interface "overrun" is detected. This occurs if a data byte follows a read buffer, read modified, or erase all unprotected command, or if more than two data bytes follow a copy command.</li> </ul> <p>This bit is set with Control Check, Intervention Required, Data Check, or Data Check with Unit Specify, to indicate that the errors that set these sense bits were detected while the 3270 CU was executing an operation with the "from" device during a copy command.</p>

Figure 8-13 (Part 2 of 2). Remote Status and Sense Byte Definition

Status/Sense Bits	Explanation	
	Response	Request
PE (Address not available)	Bits 1 through 7 of TH byte 2 are not a valid device address or the device adapter card is not installed in the 3271.	NA
CC	A timeout check is caused by the addressed device. The operation is tried twice before the CC bit is set.	NA
CC, OC	The "from" device fails to complete an operation or to respond to the 3271 within a specified time period (timeout check) during a copy command operation.	NA
DC	<ol style="list-style-type: none"> <li>1. The 3271 or 3275 detects a parity or cursor check in its buffer during a command operation.</li> <li>2. The 3271 detects bad parity on data received from the addressed device. The operation is attempted twice before the DC bit is set.</li> </ol>	A parity error is detected by the 3271 on a data transfer to the NCP as a result of a poll or a parity error detected in the 3275.
DC, US (3271 only)	<ol style="list-style-type: none"> <li>1. A parity check or cursor check is detected by the addressed device on the data it is sending to the 3270 CU.</li> <li>2. The device detects a parity or cursor check in its buffer during a command operation.</li> </ol>	A parity check or cursor check is detected by the polled device on the data it is sending to the 3271 CU.
DC, OC (3271 only)	The 3271 detects a parity check on the data transferred from the "from" device during a copy command operation.	NA
DC, OC, US	Sent when the "from" device detects an internal parity or cursor check while performing the copy command.	NA
IR	The addressed device is not available or the addressed printer is not ready.	NA
IR, OC (3271 only)	The from device is not available on a copy command.	NA
IR, EC, US	The addressed printer is mechanically disabled and cannot recover.	NA
OC	<ol style="list-style-type: none"> <li>1. The copy command data stream contains more or less than two bytes (the CCC and the "from" device address). The copy command is aborted.</li> <li>2. One or more data bytes followed an erase all unprotected command (buffer overrun).</li> <li>3. A data byte followed a read type command in the data stream received at the device.</li> </ol>	NA NA
OC, US (3271 only)	The device has a locked buffer during a copy command operation. (Refer to paragraph titled "Copy Command" in the section on Commands and Orders).	NA
EC, US (3271 only)	A character generator error or a mechanical failure is detected at the printer but recovery occurs.	NA

**Figure 8-14 (Part 1 of 2). Remote Error Status and Sense Responses and Requests**

Status/Sense Bits	Explanation	
	Response	Request
RE, CR	An invalid command is detected (first byte of data). For example, a copy command is sent to the 3275.	NA
EC	Character generator error (3275 only) in printer.	Bad parity from a device (3271 only).
EC, DC	Transmit parity error has occurred. If a buffer was obtained during the operation, the data check bit is also set.	NA
DE	The poll bit finds a device which was previously recorded as busy, as not busy. Transmission of an I frame with read or write type data resets this bit.	The poll bit finds a device which was previously recorded as unavailable or not ready, as available and ready.
IR	The addressed printer is out of paper, power has been turned off, or the printer cover is open.	NA
IR, EC (3275 only)	Power is off at the 3284 model 3 printer or a malfunction is detected.	NA
OC, DB	The "from" device receiving a copy command is busy. The device is busy performing an operation, a printout, reading data from the Operator Identification Card Reader, or performing a keyboard operation.	NA
DB	The addressed device is busy.	NA

**Notes:**

1. There are other conditions of multiple status that can occur which are not included here; for example, an unpredictable catastrophic card failure or multiple error conditions occurring simultaneously could cause an undefined combination of status and sense bits. If a multiple status condition occurs, each bit must be checked separately to determine the cause(s) of the failure.

**Figure 8-14 (Part 2 of 2). Remote Error Status and Sense Responses and Requests**

Sense/ Status Bit	Detected during 3270 Operation	
	Response	Request
PE (Address not available)	D, P	
CC	D, P	
CC, OC	D, P	
DC	D, P	D, P
DC, US	D, P	D, P
DC, OC	D, P	
DC, OC, US	D, P	
IR	D, P	
IR, OC	D, P	
IR, EC, US	P	
OC	D, P	
OC, US	D, P	
EC, US	P	
FIE, CR	D, P	
EC	D, P	D, P
DC, US, DE	D, P	
IR, EC	D	
DE	D, P	D, P
OC, DB	D, P	
RR	D, P	
DB	D, P	

Legend:  
 NA — Not applicable  
 D — Display (3277 or 3275)  
 P — Printer

**Figure 8-15. Remote Status and Sense Conditions**

Device Number	TH Address Field							
	Bits:	1	2	3	4	5	6	7
0		1	0	0	0	0	0	0
1		1	0	0	0	0	0	1
2		1	0	0	0	0	1	0
3		1	0	0	0	0	1	1
4		1	0	0	0	1	0	0
5		1	0	0	0	1	0	1
6		1	0	0	0	1	1	0
7		1	0	0	0	1	1	1
8		1	0	0	1	0	0	0
9		1	0	0	1	0	0	1
10		1	0	0	1	0	1	0
11		1	0	0	1	0	1	1
12		1	0	0	1	1	0	0
13		1	0	0	1	1	0	1
14		1	0	0	1	1	1	0
15		1	0	0	1	1	1	1
16		1	0	1	0	0	0	0
17		1	0	1	0	0	0	1
18		1	0	1	0	0	1	0
19		1	0	1	0	0	1	1
20		1	0	1	0	1	0	0
21		1	0	1	0	1	0	1
22		1	0	1	0	1	1	0
23		1	0	1	0	1	1	1
24		1	0	1	1	0	0	0
25		1	0	1	1	0	0	1
26		1	0	1	1	0	1	0
27		1	0	1	1	0	1	1
28		1	0	1	1	1	0	0
29		1	0	1	1	1	0	1
30		1	0	1	1	1	1	0
31		1	0	1	1	1	1	1

**Figure 8-16. Device Addressing for 3271 Control Unit Models 11 and 12**

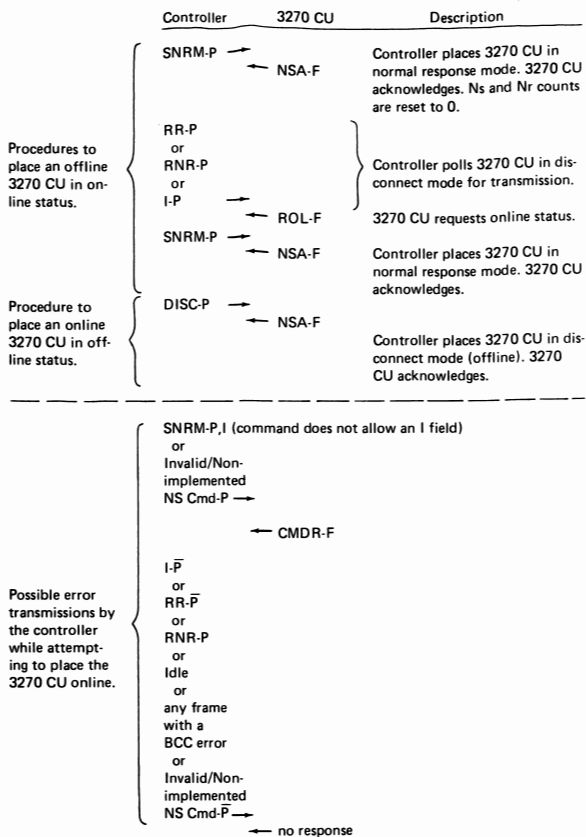

Note: Only SDLC bytes that are significant for the sequence being illustrated are shown in the diagram.

P/F=poll/final bit

I = information frame

dash (-) above a letter = not set to 1.

Figure 8-17. Online and Offline Sequence/Response Diagram

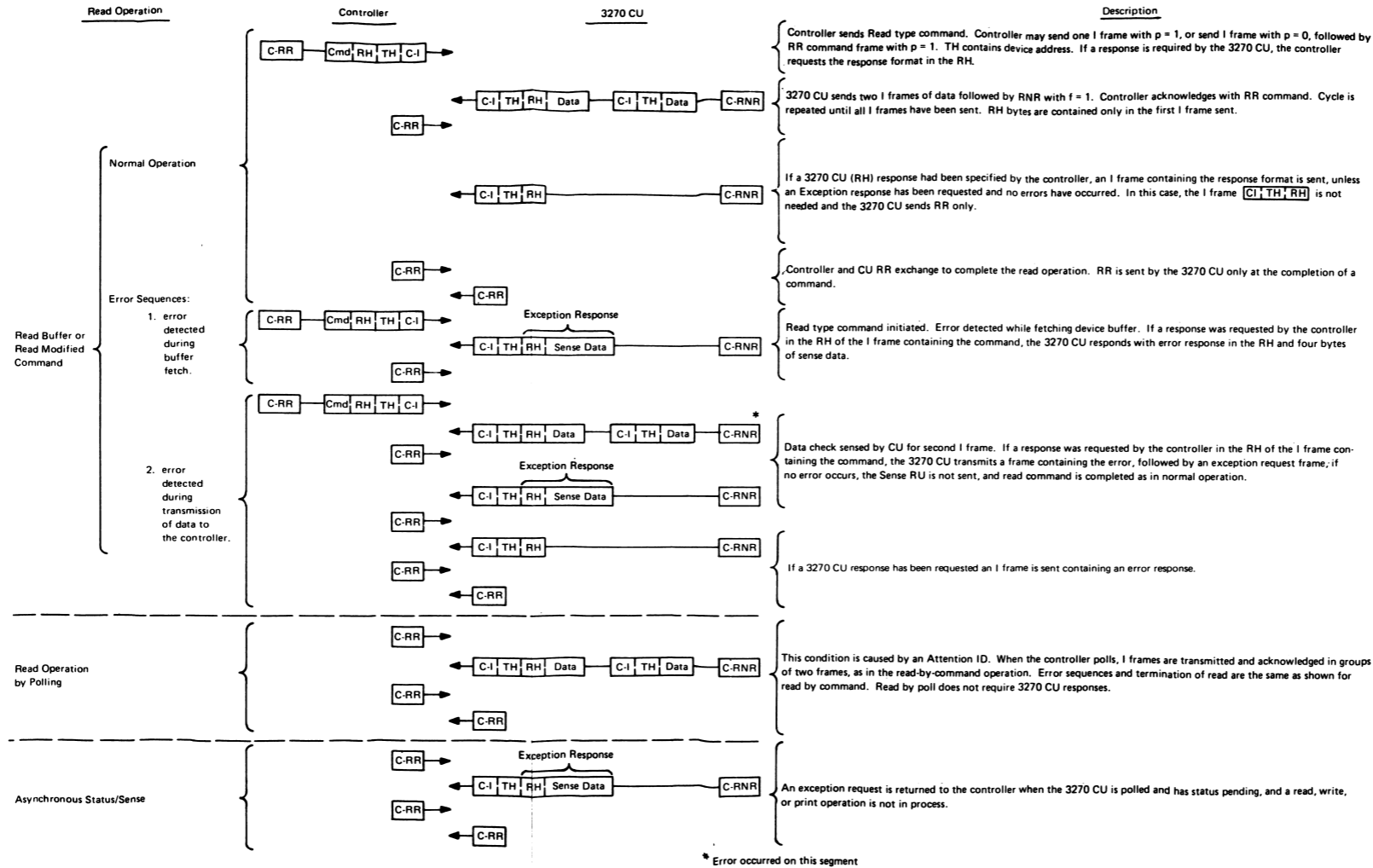

LEGEND:

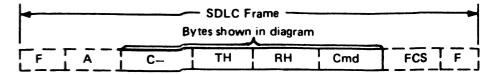

repetitive bytes: initial and ending F, A, and FCS bytes are omitted from diagram.

- F, 8-bit flag (01111110) sequence
- A, 8-bit CU address field
- C, 8-bit control field; specifies transmission format: C-I (Information field)
- C-RR/RNR (Supervisory Commands and Responses)
- C-SNRM/DISC/NSA/ROL/CMDR (non-sequenced format)
- FCS, 16-bit frame check sequence
- TH, 16-bit transmission header; includes device address
- RH, 24-bit request/response header; specifies definite response (DR), exception (EX), and pacing (P) request and response formats.
- P/F bit, poll/final bit contained in the C field

Note: A number of DR, EX, and P request/response formats are available.

Figure 8-18. SDLC Read Type Command Sequence/Response Diagram

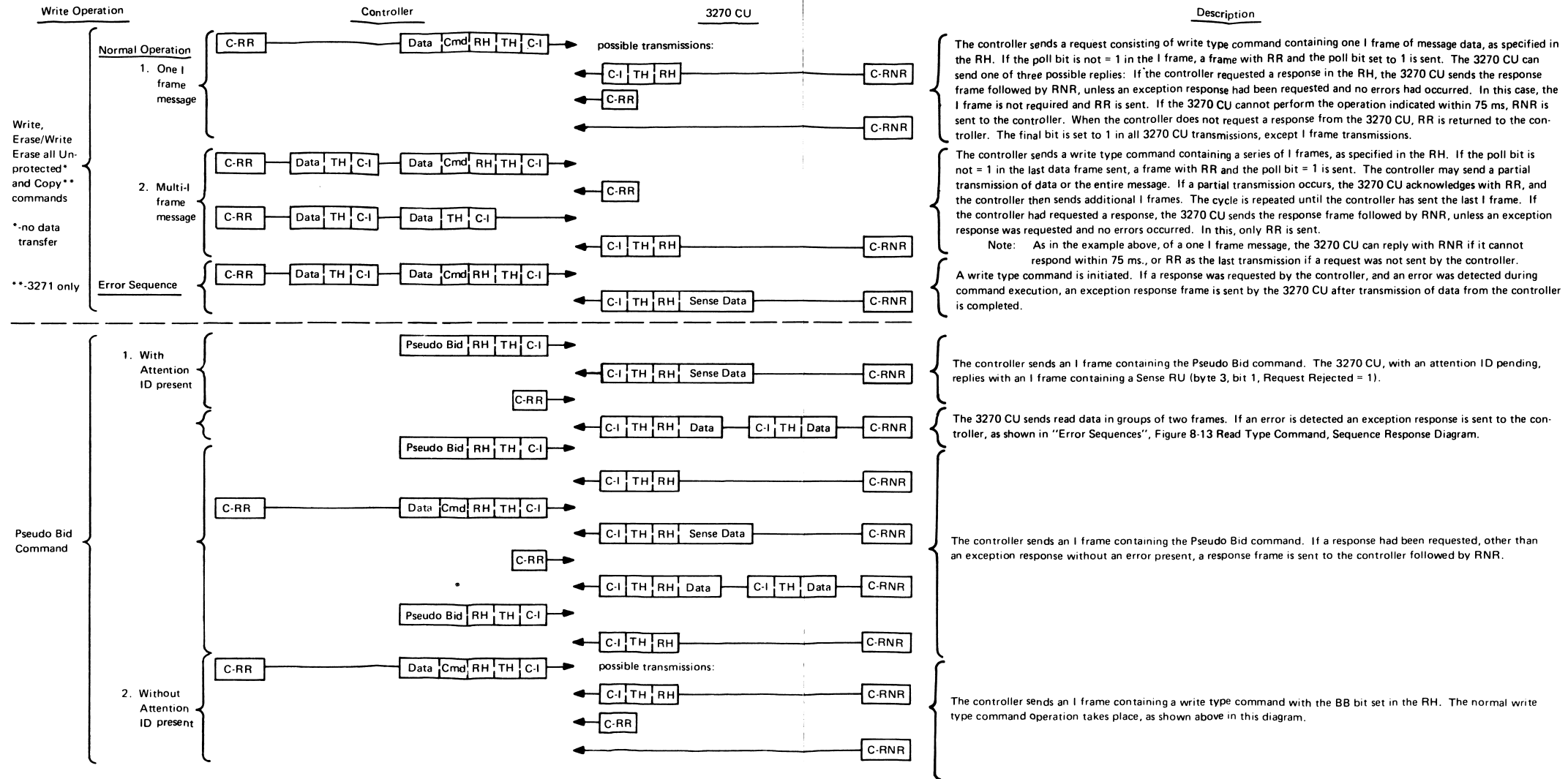

LEGEND:

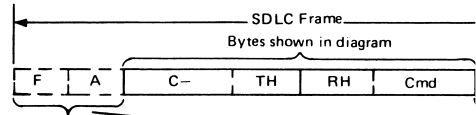

repetitive bytes: initial and ending F, A, and FCS bytes are omitted

- F, 8-bit flag (01111110) sequence.
- A, 8-bit CU address field.
- C, 8-bit control field: specifies transmission format:
  - C-I (Information field)
  - C-RR/RNR (Supervisory Commands and Responses)
  - C-SNRR/DISC/NSA/ROL/CMR (non-sequenced format)
- FCS, 16-bit frame check sequence
- TH, 16-bit transmission header; includes device address
- RH, 24-bit request/response header; specifies definite response (DR), exception (EX), and pacing (P) request and response formats.
- P/F bit, poll/final bit contained in the C field

Note: A number of DR, EX, and P request/response formats are available.

Figure 8-19. SDLC Write Type Command Sequence/Response Diagram

## Appendix A. 3270 System Publications

The following is a list of publications for the 3270 system:

Title	Form No.
3271/72 CU Parts Catalog	S126-0004
3275/77 DS Parts Catalog	S126-0005
3284/86 Printer Parts Catalog	S126-0006
3288 Printer Parts Catalog	S126-0008
3271 Mod 1 and 2 MLTG	SY27-2311
3271/75 - 11 & 12 MLTG	SY27-2476
3272 MLTG	SY27-2312
3275 Mod 1 & 2 MLTG	SY27-2313
3275 Dial MLTG Mod 1 and 2	SY27-2329
3275 Dual Case MLTG Mod 1 and 2	SY27-2344
3275 Model 3 MLTG	SY27-2359
3277 MLTG	SY27-2314
3277 Dual Case MLTG	SY27-2345
3277 Signature Display MLTG	SY27-2357
3277-1 1980-C24 Printer Attachment MLTG	PN 1841015
3275-1 & 2/3277-2 Radiation Control Mod MLTG	SY27-2358
3284/86-1 & 2 MLTG	SY27-2315
3284/86-1 & 2 APL MLTG	SY27-2420
3284/86-3 MLTG	SY27-2457
3284/86-1 & 2 Margin Stop Variable MLTG	SY27-2334
3284/86-3 Margin Stop Variable MLTG	SY27-2460
3284/86-1 & 2 VFIC MLTG	SY27-2341
3284/86 VFIC MLTG	SY27-2464
3284/86-1 & 2 Dual Case MLTG	SY27-2456
3284/86-3 Dual Case MLTG	SY27-2459
3284/86 Forms Tractor MLTG	SY27-2356
IDR-M Card Reader MLTG/Parts	SY26-4188
3288-2 MLTG	SY27-2401
3270 System Installation	SY27-2349

### CUSTOMER MANUALS

3270 IDS Introduction	GA27-2739
3270 IDS Operator's Guide	GA27-2742
3270 IDS Installation Manual	GA27-2787
3270 IDS Component Description	GA27-2749
3270 IDS Problem Determination Guide	GA27-2750
3270 IDS RFT Guide	GA27-2774
Forms Design Reference Guide for Printers	GA24-3488
Custom Feature Descriptions (RPQs)	
3284/86 Printer Margin Stop Variable	GA27-2752
3284/86 Printer VFIC	GA27-2753
3270/IDS Dual Case Feature	GA27-2758
3284/86 Printer Forms Tractor	GA27-2773
3270 IDS Signature Display	GA27-2775
Assembly of Coaxial Cables and Accessories for IBM Products	GA27-2805

## Customer Manuals (cont)

Title	Form No.
Introduction to the IBM 3270 Data Analysis-APL Feature	GA27-2788
Introduction to Programming the IBM 3270	GC27-6999

## DIAGNOSTIC USER MANUALS

IBM Maintenance Diagnostic Program – Local 3270 Online Tests	D99-3270A
IBM Maintenance Diagnostic Program – Remote 3270 Online Tests	D99-3270B
IBM Maintenance Diagnostic Program – Remote 3270 Online Tests/3705 NCP	D99-3270C
IBM Maintenance Diagnostic Program – 3270 Display System SNA Online Tests	D99-3270D

## 3270 SYSTEM TEST TAPES

The following is a list of pre-recorded test tapes for the 3270 system:

3271 EBCDIC Leased Line Tape	SY27-2318
3271 ASCII Leased Line Tape	SY27-2319
3275 EBCDIC Leased Line Tape	SY27-2320
3275 ASCII Leased Line Tape	SY27-2321
3275 EBCDIC Dial Tape	SY27-2325
3275 ASCII Dial Tape	SY27-2326
3271/3275 SDLC Tape	SY27-2412

## Appendix B. 3270 Tools and Test Equipment

Tool Part No.	Machine Type							Description
	3271	3272	3275	3277	3284	3286	3288	
18463					X	X		Stoning Tool
450459					X	X		Gram Gauge
453212	X	X	X	X	X	X	X	General Logic Probe
453705							X	Unlatch Tool
1655219			X					3275 SNA-IF Overlay
1655220	X							3271 SNA-IF Overlay
1655221	X							3271 MLPXR Overlay
1744195	X		X					CRAU-SDLC****
1814629							X*	Platen Gap Gauge
1830679	X	X	X	X	X	X	X	SIU (Model 2 SDLC)
1842748							X*	3288 SIU Overlay
2525953					X*	X*		Feeler Gauge 0.001 in. (0.0254 mm)
2565170			X*	X*				Alignment Mask**
2570250	X	X	X	X	X	X	X	SIU (Model 1)
2577899				X*				Alignment Mask***
2617969					X*	X*		Wire Cleaning Tool
2621412	X*	X*		X	X	X	X	Coaxial Cable 6 ft. (1.83 m)
BM2621480	X	X	X	X	X	X	X	Overlay Set (SIU)
2640796					X	X		PC Board Check Tool
5492081	X	X	X	X	X	X	X	Jumper Wire

\*These tools are included in the shipping group for the machine.  
 \*\*This mask is used on 3275 and 3277 Model 2.  
 \*\*\*This mask is used on 3277 Model 1.  
 \*\*\*\*These tools used for SDLC.

B



## Index

- Addressing:**  
Device for 3271 Control Unit Models 11 and 12 (SDLC) 8-23  
Remote Control Unit and Device 1-58,1-59,1-60  
3272 Device:  
16 or Fewer Devices per 3272 1-50  
17 or More Devices per 3272 1-50
- Analog Cards, 3277 5-21,5-28**
- Assignments for Internal 6-Bit Structured Data (Fig. 1-24) 1-42**
- Asynchronous Status and Sense Conditions, Local (Fig. 1-36) 1-55**
- Attention ID (AID) Configurations (Fig. 1-26) 1-45**
- Attention ID (AID) Encoding 1-31**
- Attribute Character Bit Definition (Fig. 1-6) 1-24**
- Block Diagrams:**  
3271 Models 1 and 2 (Fig. 2-1) 2-7  
3271 Models 11 and 12 (Fig. 8-2) 8-7  
3272 (Fig. 3-1) 3-7  
3275 Models 1 and 2 (Fig. 4-1) 4-7  
3275 Models 11 and 12 (Fig. 8-3) 8-8  
3277 (Fig. 5-1) 5-9  
3284/86 (Fig. 6-1) 6-7  
3288 (Fig. 7-1) 7-9
- Buffer Orders and Order Codes (Fig. 1-30) 1-49**
- Cables, Flat, 3271 2-20**
- Cabling Error, 3271 2-20**
- Card Caddy Lists 1-9**
- Card/Gate Layout by Function:**  
3271 Models 1 and 2 2-11  
3271 Models 11 and 12 8-9  
3272 3-9  
3275 Models 1 and 2 4-12  
3275 Models 11 and 12 8-10  
3277 5-10  
3284/86 6-9,6-10  
3288 7-10
- Card Jumpering (3284/86) 6-30,6-41**
- Card Replacement Chart (SDLC) 8-5**
- Card Substitution Lists:**  
3271 Models 1 and 2 2-12  
3271 Models 11 and 12 8-6  
3272 3-10  
3275 Models 1 and 2 4-17  
3275 Models 11 and 12 8-6  
3277 5-11  
3284/86 6-11  
3288 7-6
- Coaxial Cable Check 1-15**
- Coaxial Cable Information:**  
3271 2-20  
3272 3-16  
3277 5-24
- Coaxial Cables and BNC Connectors 1-5**

Command Codes, Local and Remote (BSC)	1-43
Command Reject (CMDR) Message Format (SDLC)	8-15
Command Reject (CMDR) Status Bytes (SDLC)	8-17
Commands:	
Control Type (BSC)	1-76
Control Type (SDLC)	8-26
Copy (BSC)	1-76
Copy (SDLC)	8-26
Erase All Unprotected (BSC)	1-76
Erase Write (BSC)	1-76
Erase Write (SDLC)	8-26
General Description (BSC)	1-43
Read Buffer (BSC)	1-78
Read Buffer (SDLC)	8-25
Read Modified (BSC)	1-78
Read Modified (SDLC)	8-25
Write (BSC)	1-76
Write (SDLC)	8-26
Control-Type Command Sequence/Response Diagram (BSC)	1-76
Control Unit Addressing (Remote)	1-58
Control Unit Sequence Latches and Table of Sequences	1-21
Control Words	1-27,1-28
Controls and Indicators	1-67
Copy Control Character (CCC) (Fig. 1-28)	1-47
Crash Stopping or Equipment Checks	6-35
CU Control Word Formats (Fig. 1-16)	1-33
CU CW1 Detected on 3277 Device	1-27,1-31
CU CW1 Detected on 3284/3286/3288	1-28,1-31
CU CW1 Scoping Points	1-31
CU Data Word Format (Fig. 1-15)	1-33
Data Analysis - APL Feature Character Interchange Codes (Fig. 1-23)	1-40
Device Addressing for 3271 Control Unit Models 11 and 12 (SDLC)	8-21
Device Addressing, 3272 - 16 or Fewer Devices per 3272 (Fig. 1-31)	1-50
Device Addressing, 3272 - 17 or More Devices per 3272 (Fig. 1-32)	1-50
Device Addressing (Remote) (Fig. 1-37)	1-58
Device Buffer Transfer (Data Words) to CU (Fig. 1-17)	1-35
Device End Lost	2-22
Device Serdes	1-35,1-36
Display Status Word (Fig. 1-8)	1-9
Display Status Word Detected on 3271 Control Unit	1-26
Display Status Word Detected on 3272 Control Unit	1-27
EC Cross-Reference Lists:	
3271	2-15
3272	3-13
3275	4-23
3277	5-15
3284/86	6-15
3288	7-14
EIA Connectors:	
3271	2-24
3275	4-34
Ending Status and Sense Conditions - Local (Fig. 1-35)	1-53
Equipment Checks or Crash Stopping	6-35
Error Status and Sense Responses	1-62
Error Status and Sense Responses and Requests, Remote (SDLC)	8-21
Example of Maintained Connection, Sequence/Response Diagram, Dial Feature (Fig. 1-49)	1-84

Facilities Error Recognition System (FERS) 1-14  
 Feature Identification, Version Level:  
     3275 4-32  
     3284/86 6-42  
 Flat Cables, 3271 2-20  
 Forms:  
     Jamming 6-26,7-16  
     Standard Specifications 6-28,6-29,7-16,7-18,7-19,7-20,7-21,7-23  
     VFIC Specifications 6-46,6-47,6-48  
 Forms Tractor RPQ WD4031 Service Information 6-44  
 Frame Format, (SDLC) 8-11  
  
 General Logic Probe 1-20  
 General Poll 1-43  
 General Poll and Specific Poll, Sequence/Response Diagram (Fig. 1-42) 1-70  
 Ground Checks 1-7  
 Ground Loops 1-7  
  
 Hex Codes:  
     ASCII 1-38,1-42  
     EBCDIC 1-37,1-39,1-40,1-42  
  
 I-Format, Data Message (SDLC) 8-11  
 Index Failures 6-25,6-36,6-38  
 Indicators and Controls (Fig. 1-41) 1-68  
 Initial Selection 1-43  
 Initial Selection w/Error Status 1-43  
 Initial Status and Sense Conditions - Local (Fig. 1-34) 1-52  
 Interface, Control Unit to Device 1-3  
 Interface, Control Unit to Device, RPQ AB4820 (5000 Feet) 1-4  
 Interface Code:  
     Data Analysis - APL Feature 1-40  
     U.S. ASCII 1-38  
     U.S. EBCDIC 1-37  
 Intermittent Troubleshooting Procedures (SDLC) 8-3  
  
 Keyboard Information 5-22,5-23,5-24  
  
 Light-Emitting Diode (LED) 1-20  
 Lightning Protection 5-25  
 Line Adapter Installation (3275) 4-33  
 Line Cords 5-23  
 Line Error ECs 3271 2-20  
 Line or Modem Scoping Procedure:  
     3271 2-21  
     3275 4-30  
 Local and Remote Command Codes (Fig. 1-25) 1-43  
 Logic Board Information:  
     3275 4-32  
     3277 5-27  
     3284/86 6-46  
     3288 7-10,7-11  
 Logic Levels - 3270 VTL 1-6  
 Logic Manual Storage 1-17  
 Logic Probe, General 1-20  
  
 Maintenance Monitor (3284/86) 6-37  
 Manual, Logic Storage 1-17  
 Message Buffer Bit Assignment 1-35  
 Missing Grounds 1-17

MLTG Updates (3284/86)	6-43
Modem or Line Scoping Procedure	2-21
Motor Control Card Jumpering	6-41
Multiplexer Shift Register Bits	1-35
New Line/End of Message Orders Printing as 5's and 9's	6-42
Non-Sequenced Message Format (SDLC)	8-16
Online and Offline Sequence/Response Diagram (SDLC) (Fig. 8-17)	8-24
Order Codes and Buffer Orders	1-49
Parts Catalog Corrections and Additions 3284/86:	
Forms Tractor RPO	6-44
Standard	6-37
Variable Margin RPO	6-44
Platen Assembly (3288)	7-17
Platen/Ribbon Shield Assemblies (3288)	7-27
Poll, General and Specific	1-43
Poll Sequences, General and Specific:	
Addresses	1-58
Sequence/Response Diagram	1-72
Power Supplies, Voltages	2-23,6-34
Power Supply Ripple (Fig. 1-1)	1-6
Print Belt Motor Drive Pulse (3288)	7-29
Print Head Plug Description (3288)	7-13
Printer Cover Window Hazard	6-37
Printer Printed Circuit Board Damage	6-37
Printer Status Word (Fig. 1-9)	1-29
Printer Status Word Detected on 3271 Control Unit	1-26
Printer Status Word Detected on 3272 Control Unit	1-27
Probe, General Logic	1-20
Problem Development Procedures (SDLC)	8-3
Problem Repair Procedures (SDLC)	8-5
Quote Marks on Screen, 3275	4-33
Read Modified Command (BSC)	1-44
Read Type Command:	
Sequence/Response Diagram, BSC (Fig. 1-46)	1-78
Sequence/Response Diagram, SDLC	8-25
Remote Control Unit and Device Addressing (Fig. 1-37)	1-58
Remote Error Status and Sense Responses and Requests, SDLC (Fig. 8-14)	8-21
Remote Status and Sense Byte Definitions:	
BSC (Fig. 1-38)	1-61
SDLC (Fig. 8-13)	8-19
Remote Status and Sense Conditions:	
BSC (Fig. 1-40)	1-66
SDLC (Fig. 8-15)	8-23
Request and Response Format, SDLC (Fig. 8-12)	8-18
Request for Test (RFT)	1-19
Request/Response Header (RH), SDLC	8-13
Ribbon Jamming/Feeding Problems	6-30, 6-43, 6-44, 7-31
Ribbon Lift Arm Assemblies (3288)	7-30
Ripple, Power Supply	1-6
SDLC	8-3
SDLC Card List	8-5
SDLC Frame Format	8-11
Selection Addressing, Sequence/Response Diagram (Fig. 1-44)	1-74
Sense Bit Description (Fig. 1-29)	1-48

Sense/Status Message Format (SDLC) 8-14  
 Sequence Latches 1-21  
 Sequence/Response Diagrams (Remote BSC):  
   Control-Type Commands (Fig. 1-45) 1-76  
   Example of Maintained Connection (Fig. 1-49) 1-84  
   Poll Sequences, General and Specific (Fig. 1-42) 1-70  
   Read-Type Commands (Fig. 1-43, 1-46) 1-72,1-78  
   Selection Addressing Sequence (Fig. 1-44) 1-74  
   Status Message Transmission with Dial Feature (Fig. 1-50) 1-86  
   TCU - Initiated Transmission (Fig. 1-48) 1-82  
   3275 Initiated Transmission (Fig. 1-47) 1-80  
   Write - Type Commands (Fig. 1-45) 1-76  
 Sequence/Response Diagram (SDLC):  
   Online and Offline (Fig. 8-17) 8-24  
   Read Type Command (Fig. 8-18) 8-25  
   Write Type Command (Fig. 8-19) 8-26  
 Serdes, Device 1-35,1-36  
 Serial Clock Transmit (SCT) Test Point 2-20  
 Service Aids:  
   3270 1-15  
   3271 2-20  
   3272 3-16  
   3275 4-30  
   3277 5-21  
   3284/86 6-25  
   3288 7-16  
 Shipping Group (3277) 5-26  
 Specific Poll 1-43  
 Specific Poll Sequence/Response Diagram 1-70  
 Specific Poll w/Status Msg 1-43  
 Status and Sense Byte Definitions, Remote:  
   BSC 1-61  
   SDLC 8-19  
 Status and Sense Conditions:  
   Asynchronous Local (Fig. 1-36) 1-55  
   Ending, Local 1-57  
   Remote (BSC) 1-66  
 Status and Sense Responses, Error 1-62  
 Status and Sense Responses and Requests, Remote Error (SDLC) 8-21  
 Status Byte Bit Assignments (Fig. 1-33) 1-51  
 Status/Control Word (3271) (Fig. 1-11) 1-30  
 Status/Control Word (3272) (Fig. 1-10) 1-30  
 Status Message Transmission with Dial Feature, Sequence/Response Diagram  
   (Fig. 1-50) 1-86  
 Status/Sense Message Format (SDLC) 8-14  
 Status Word Sent by Device (Fig. 1-18) 1-36  
 Status Word Waveform (Fig. 1-12) 1-30  
 Status Words 1-26,1-27  
 Status Words Scoping Points 1-42  
 Stepper Motor and Speed Adjustment Service Hints (3284/86) 6-42  
 Supervisory Message Format (SDLC) 8-16  
 Symptom - Fix Lists:  
   3271 2-3  
   3272 3-3  
   3275 4-3  
   3277 5-3  
   3284/86 6-3  
   3288 7-3  
 System Grounding, 3270 1-8  
 System 3 - 8000 bps 2-22

TCU-Initiated Transmission, Sequence/Response Diagram, Dial Feature (Fig. 1-48)	1-82
TDAT	2-23
Test Point - Serial Clock Transmit (SCT)	2-20
Test Request Function	1-17
Test Tape Form Numbers	A-2
Tools and Test Equipment:	
AMP Tool	1-17
General Logic Probe	1-20
SIU	2-23
TDAT	2-23
3270 System	B-1
Transducer Adjustments	6-31
Transmission Header (TH) (SDLC)	8-13
United States I/O Interface Code - ASCII (Fig. 1-20)	1-38
United States I/O Interface Code - EBCDIC (Fig. 1-19)	1-37
Variable Margin RPQ EB 3995 Service Information	6-41,6-44
Version Level Feature Identification:	
3275	4-32
3284/86	6-42
VFIC Form - Locations and Dimensions (Fig. 6-14)	6-48
VFIC RPQ Service Information	6-39,6-40,6-46
Voltage Jumpers, 3271	2-20
VTL Logic Levels	1-6
Write Command	1-43
Write Control Character (Fig. 1-27)	1-46
Write-Type and Control-Type Commands, Sequence/Response Diagram, BSC (Fig. 1-45)	1-76
Write-Type Command Sequence/Response Diagram, SDLC (Fig. 8-19)	8-26
6-Bit Structured Data (SDLC)	8-12
3270:	
Commands	1-43
Control Unit to Device Interface	1-3
Control Unit to Device Interface (RPQ AB4820)	1-4
CU Message Response to Polling or Read Modified Command (Fig. 1-43)	1-72
Recommended Card Caddy Lists	1-9
Service Aids	1-15
System Grounding (Fig. 1-2)	1-8
System Publications	A-1
Tools and Test Equipment	B-1
3271:	
A-Gate Card Layout by Function (Fig. 2-2)	2-11
Card Substitution List	2-12
CU Functional Block Diagram (Fig. 2-1)	2-7
EC Cross Reference	2-15
EIA Connections	2-24
Remote Commands	1-43
Service Aids	2-20
Symptom Fix List	2-3
3272:	
A-Gate Card Layout by Function (Fig. 3-3)	3-9
and Device Addressing, 16 or Fewer Devices per 3272 (Fig. 1-31)	1-50
and Device Addressing, 17 or More Devices per 3272 (Fig. 1-32)	1-50
Buffer Storage Address Control (Fig. 3-2)	3-8

**3272 (Cont'd):**

- Card Substitution List 3-10
- Control Unit Data Flow (Fig. 3-1) 3-7
- EC Cross-Reference 3-13
- Service Aids 3-16
- Symptom Fix List 3-3

**3275:**

- A-Gate Card Layout by Function, Display (Fig. 4-6) 4-12
- A-Gate Card Layout by Function, Model 3 (Fig. 4-8) 4-14
- B-Gate Card Layout by Function, Dial (Fig. 4-10) 4-16
- B-Gate Card Layout by Function, Leased (Fig. 4-7) 4-13
- B-Gate Card Layout by Function, Model 3 (Fig. 4-9) 4-15
- Card Substitution List 4-17
- Display Data Flow (Fig. 4-1) 4-7
- EC Cross-Reference 4-23
- EIA Connections 4-34
- Initiated Transmission, Sequence/Response Diagram, Dial Feature (Fig. 1-47) 1-80
- Remote Commands 1-43
- Remote Interface and Control Unit Data Flow (Dial), ASCII (Fig. 4-5) 4-11
- Remote Interface and Control Unit Data Flow (Dial), EBCDIC (Fig. 4-4) 4-10
- Remote Interface and Control Unit Data Flow (Leased Line), ASCII (Fig. 4-2) 4-8
- Remote Interface and Control Unit Data Flow (Leased Line), EBCDIC (Fig. 4-3) 4-9
- Service Aids 4-30
- Symptom Fix List 4-3

**3277:**

- A-Gate Card Layout by Function (Fig. 5-2) 5-10
- Card Substitution List 5-11
- Data Flow (Fig. 5-1) 5-9
- EC Cross-Reference 5-15
- Service Aids 5-21
- Symptom Fix List 5-3

**3284/3286:**

- EC Cross-Reference 6-15
- Model 1 and 2 A-Gate Card Layout by Function (Fig. 6-2) 6-8
- Model 1 and 2 A-Gate Card Layout by Function, Dual Case RPQ (Fig. 6-3) 6-8
- Model 1 and 2 A-Gate Card Layout by Function, VFIC RPQ (Fig. 6-4) 6-9
- Model 1 and 2 Functional Block Diagram (Fig. 6-1) 6-7
- Model 3 A-Gate Card Layout by Function (Fig. 6-5) 6-9
- Model 3 A-Gate Card Layout by Function, Dual Case RPQ (Fig. 6-6) 6-10
- Model 3 A-Gate Card Layout by Function, VFIC RPQ (Fig. 6-7) 6-10
- Model 1 and 2 Card Substitution List 6-11
- Service Aids 6-25
- Symptom Fix List 6-3
- VFIC Printer Forms Specifications 6-46

**3288:**

- A-Gate Card Layout by Function (Fig. 7-2) 7-10
- Block Diagram (Fig. 7-1) 7-9
- Card Substitution List 7-6
- EC Cross-Reference 7-14
- Logic Board Layout 7-11
- Printer Card Gate Layout 7-12
- Service Aids 7-16
- Symptom Fix List 7-3

4800/7200-bps Installation (3275) 4-33

8000-bps - System 3 2-22



CUT ALONG DOTTED LINE

---

**IBM 3270 Information Display System Maintenance Handbook, Form S229-7037-3**

From \_\_\_\_\_ Office No. \_\_\_\_\_

Circle one of the comments and explain in the space provided:

Suggested Addition (page\_\_\_\_) Suggested Deletion (page\_\_\_\_) Error (page\_\_\_\_)

Explanation:

**Business Reply Mail**

No postage stamp necessary if mailed in the U.S.A.

Postage will be paid by:

International Business Machines Corporation  
Department R20  
Neighborhood Road  
Kingston, New York 12401

First Class  
Permit 40  
Armonk  
New York





Printed in U.S.A. S229-7037-3

The IBM logo consists of the letters 'IBM' in a bold, sans-serif font. Each letter is formed by a series of horizontal bars of varying lengths, creating a striped effect. The 'I' has three bars, the 'B' has six bars, and the 'M' has five bars. A small registered trademark symbol (®) is located at the bottom right of the logo.

**International Business Machines Corporation**  
**Data Processing Division**  
**1133 Westchester Avenue, White Plains, N.Y. 10604**

**IBM World Trade Americas/Far East Corporation**  
**Town of Mount Pleasant, Route 9, North Tarrytown, N.Y., U.S.A. 10591**

**IBM World Trade Europe/Middle East/Africa Corporation**  
**360 Hamilton Avenue, White Plains, N.Y., U.S.A. 10601**