

decomm hardware guide
terminals

deccomm hardware guide
terminals

First Edition, February 1973

Copyright © 1973 by Digital Equipment Corporation

The material in this manual is for informational purposes and is subject to change without notice.

The following are trademarks of Digital Equipment Corporation, Maynard, Massachusetts:

DEC	PDP
FLIP CHIP	FOCAL
DIGITAL	COMPUTER LAB

CONTENTS

GENERAL DATA COMMUNICATIONS CONSIDERATIONS

PARALLEL OPERATION	1-1
SERIAL OPERATION	1-2
20 mA NEUTRAL CURRENT	1-2
EIA/CCITT	1-3

LA30 DECwriters

LA30 DECwriter CHARACTERISTICS	2-1
General Characteristics	2-1
Data Communications	2-1
Environmental/Physical	2-2
LA30 Model Numbers	2-2
PARALLEL LA30 AS CONSOLE OR LOCAL DEVICE	2-3
SERIAL LA30 AS LOCAL OR CONSOLE DEVICE	2-4
Using DL11-A or DL11-C Interfaces	2-4
Using DM11 16-Terminal Interface	2-5
Using DJ11 or DH11 16-Terminal Interfaces	2-6
LA30 AS REMOTE DEVICE	2-7
LA30 AS LOCAL OR REMOTE TERMINAL	2-9
Equipment Selection Chart for Remote Serial LA30	2-12

VT05 ALPHANUMERIC DISPLAYS

VT05 TERMINAL CHARACTERISTICS	3-1
General Characteristics	3-1
Data Communications	3-1
Environmental/Physical	3-2
VT05 Models	3-2
VT05 USED LOCALLY (20 mA)	3-3
Using DL11-A or DL11-C	3-3
Using DM11-AA or -AC plus DM11-DA	3-4
Using DH11-AA or -AC plus DJ11-AC	3-5
VT05 USED LOCALLY (EIA)	3-6
Using DL11-B or DL11-D	3-6
VT05 USED REMOTELY (EIA)	3-7
Using DL11-D or DL11-E	3-7
Using DC11-Ax and DC11-DA	3-8
Using DM11-Ax with DM11-DB or DM11-Ax with DM11-BB and DM11-DC	3-9
Using DM11 and DJ11	3-10
Equipment Selection Chart for Remote VT05	3-11

DEC-SUPPLIED TELETYPES

INTERFACING TELETYPES TO PDP-11 SYSTEMS	4-1
General Teletype Characteristics	4-1
Data Communications	4-1
MODEL NUMBERS	4-1
REMOTE USE OF DEC-SUPPLIED TELETYPES	4-3
LOCAL USE OF DEC-SUPPLIED TELETYPES	4-4
Using DL11-A Interface	4-4
Using DM11-AA or -AC with DM11-DA	4-5
Using DH11 or DJ11	4-6
Equipment Selection Chart for Remote Use of DEC-Supplied Teletypes	4-7

**GENERAL DATA COMMUNICATIONS
CONSIDERATIONS**

A communication system can be viewed as consisting of *three* major elements:

- Terminal
- Channel
- Computer

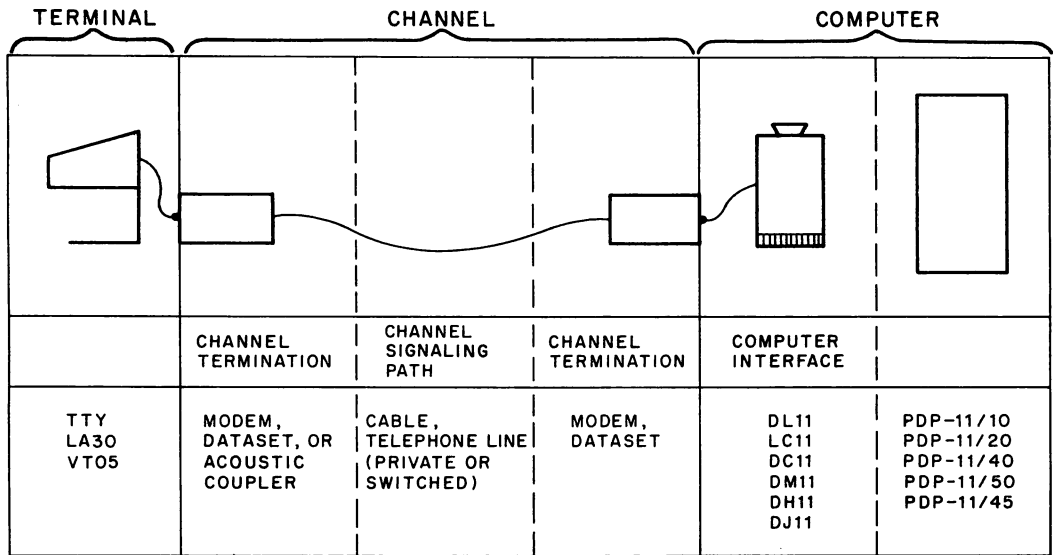

11-1577

Characteristics of the various elements *must* be matched. For instance, Baud rates of the terminal must correspond with the Baud rate capacity of the signaling path, channel terminations, and computer interface.

PARALLEL OPERATION

In parallel operation all bits of a data word are transmitted along the channel simultaneously (i.e., all bits of the word travel in parallel).

Parallel transmission is generally used within the PDP-11 system (i.e., Unibus) and for transmission of data between the PDP-11 and such local devices as the LA30-P and LP11 line printers.

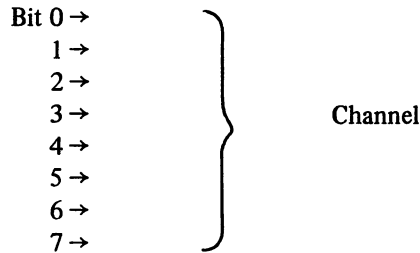

SERIAL OPERATION

In serial communications data bits travel in a single stream over a channel.

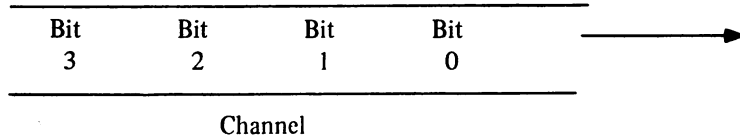

Data can be coded in many ways, for example ASCII (DEC terminals) or EBCDIC (most IBM devices). In asynchronous transmission characters are separated by stop and start bits.

An 11-unit character would contain:

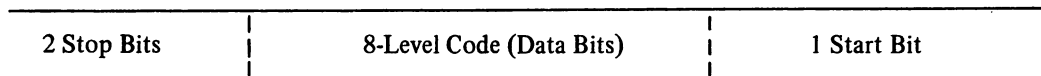

20 mA LOOP CURRENT

Because of general suitability for a wide range of applications, the use of currents in the vicinity of 20 mA is widespread for the transmission of binary serial data.

DEC Teletypes[®] and some models of the LA30 (LA30-C) and VT05 display terminals use 20 mA neutral, passive current loop signaling.

20 mA connections are usually made with Mate-N-Lok connectors, by DEC equipment.

Normally the computer interface includes a module with a female connector. The terminal (LA30-C, DEC Teletype, VT05) is supplied with a cable that terminates in a male connector.

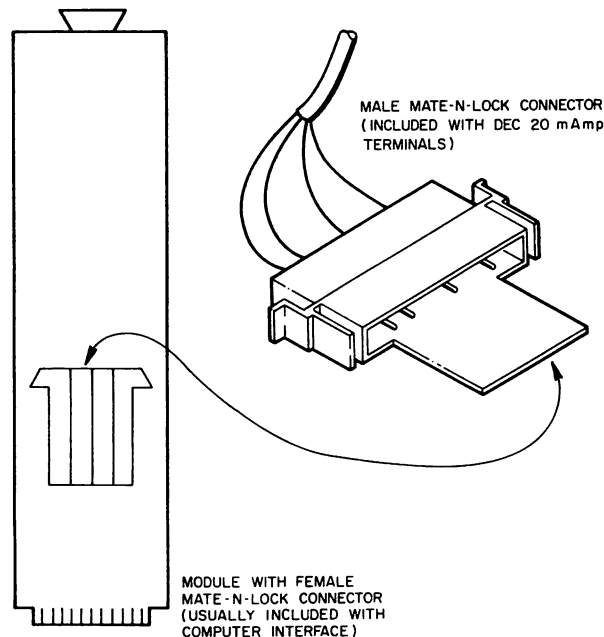

11-1578

[®] Teletype is a registered trademark of Teletype Corporation.

EIA/CCITT

Commercial standards for carriers and data communication and terminal equipment manufacturers are defined in EIA Standard RS-232C, which is prepared under the auspices of the Electronics Industries Association. The Comite Consultatif International de Telephonie et Telegraphie (CCITT) publishes similar standards for non-U.S. data communication users.

Equipment designed by DEC to transmit or receive data over voice grade lines normally conforms with EIA RS-232C and CCITT Recommendation V.24. DEC EIA devices are normally equipped with BC05 (PDP-11 products) type cables and the following connectors:

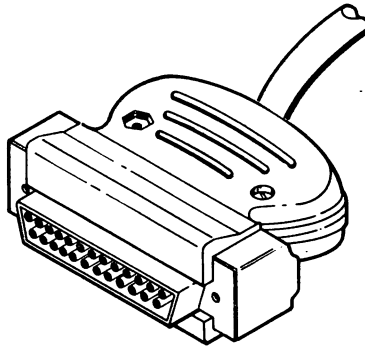

MALE CONNECTOR

11-1579

CINCH or Cannon DB25P with protective hood.

LA30 DECwriters

LA30 DECwriter CHARACTERISTICS

The LA30 DECwriter is a fast, reliable, low-cost data terminal that can be used as a console keyboard-printer or as a local or remote I/O device on a PDP-11 system.

It is interchangeable with DEC-supplied Teletypes, but offers considerably more flexibility and data communications alternatives than the Teletype.

General Characteristics

Print Speed:	30 characters/second (300 ms carriage return)
Line Length:	80 character positions
Horizontal Character Spacing:	10 characters/inch
Vertical Character Spacing:	6 lines/inch
Keyboard Characters:	97 or 128 (switch selectable)
Printing Characters:	64 upper case ASCII subset (lower case codes print in upper case)
Typeface:	5 X 7 dot matrix
Paper:	25 cm (9 7/8 in.) wide, sprocket-driven, continuous form, original plus one copy
Ribbon:	1.3 cm* (1/2 in.) X 36.5m (120 ft.), nylon

Data Communications

Code:	ASCII X3.4 1968 Parallel version: 7-level code Serial version: 7-level code and 8th bit marking (standard models are shipped without parity; however, insertion of jumpers can provide even or odd parity) 2 stop bits (1 stop bit is optional)
Baud Rates:	110, 150, 300
PDP-11 Interfaces:	LC11 (parallel) DL11 (single line serial) DC11 (dual line serial – programmable) DM11 (up to 16 lines serial) DH11 (up to 16 lines serial) DJ11 (up to 16 lines serial)
Applicable DEC Devices:	DEC DF01A Acoustic Coupler H312A Null Modem DF11-BA and DF11-BB Integral Modems H313A TTY to data set converter

*Metric measurements are rounded off to next highest tenth of a unit.

Applicable Data Sets: Bell 113A,B or equivalent (dial network)
 Bell 103A,E,G or equivalent (dial network)
 Bell 103F or equivalent (private line)

Environmental/Physical

Temperature: 10°C – 43°C (50°F – 100°F)
 Humidity: 5–90% (non-condensing)
 Power: 115 Vac, 50–60 Hz
 230 Vac, 50–60 Hz
 Power Cable Length: 4.6m (15 ft)
 Dimensions: 52 cm (20 1/2 in.) wide X 78.7 cm (31 in.) high X 60.9 cm (24 in.) deep
 Cables: 7008417 7.6m (25 ft) supplied with LA30-P
 BC05F-15 4.6m (15 ft) supplied with LA30-C
 BC05C-25 7.6m (25 ft) supplied with LA30-E

LA30 Model Numbers

Model	PDP-11 Interfaces
Parallel (Console or Local Operation)	
LA30-PA 115V, 60 Hz LA30-PB 230V, 60 Hz LA30-PC 115V, 50 Hz LA30-PD 230V, 50 Hz	LC11-A
Serial (Console or Local or Remote)	
LA30-CA 115V, 60 Hz LA30-CD 230V, 50 Hz	{ DL11-A, DL11-C DM11-AA or -AC with DM11-DA DH11-AA or -AC with DM11-DA DJ11-AC
} 20 mA	
LA30-EA 115V, 60 Hz LA30-ED 230V, 50 Hz	{ DL11-B, -D or -E DC11-A with -DC11-DA DM11-AA or -AC with DM11-DB DH11-AA or -AC with DM11-DB DM11-AA or -AC with DM11-BB and DM11-DC DH11-AA or -AC with DM11-BB and DM11-DC DJ11-AA
} EIA	

PARALLEL LA30 AS CONSOLE OR LOCAL DEVICE

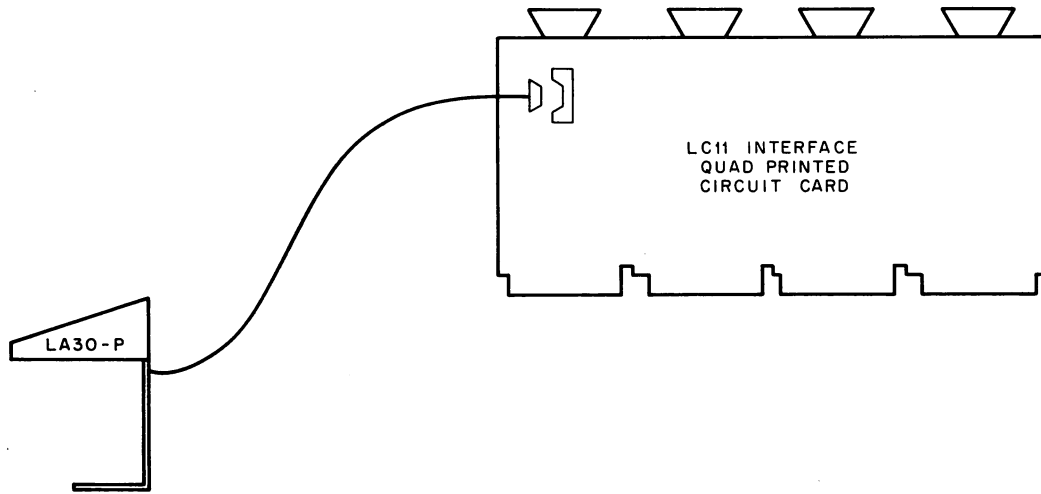

11-1582

Computer Interface Cable: 7.6m (25 ft) supplied with LA30-P

Baud Rate: 30 Bauds (30 characters/second)

Notes:

LA30-P can be used up to 50 ft from processor.

When ordering LA30-P as console device instead of DEC Teletype, system should include a paper-tape reader or a TU56 DECTape for loading programs.

Parallel version is best for console applications because the console printer software runs with no changes and makes the most of the 30 character/second print rate.

There may be a price advantage in ordering a parallel LA30 vs the serial LA30.

PDP11/10s must use the serial LA30 as console device.

SERIAL LA30 AS LOCAL OR CONSOLE DEVICE

Using DL11-A or DL11-C Interfaces

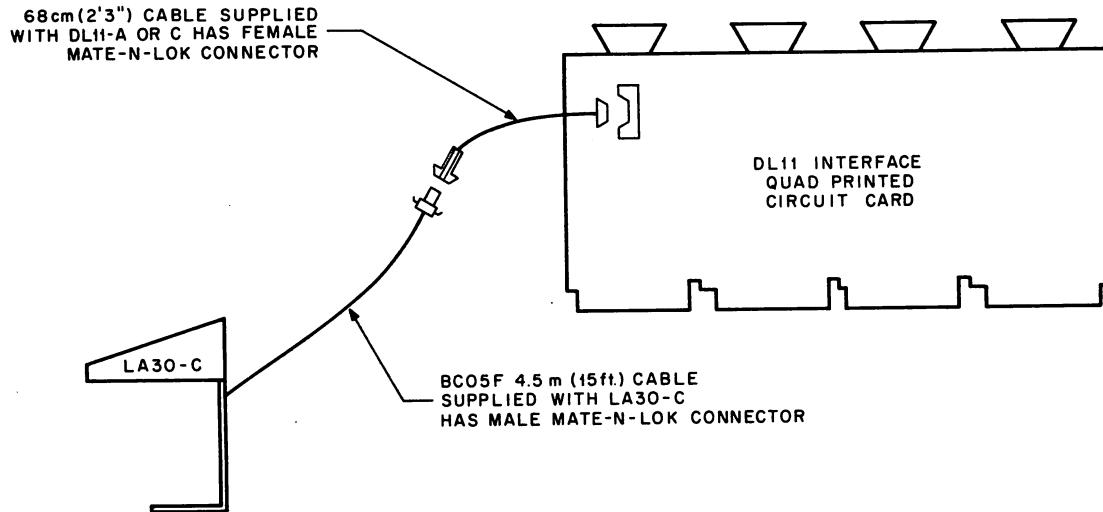

11-1583

- Baud Rates:** 110, 150, or 300 (operator selectable, but interface must match)
- DL11-A Characteristics:** Full-duplex operation
20 mA neutral current loop
Furnished with 61 cm (2 1/4 ft) cable terminated with female Mate-N-Lok connector
8 data bits, 2 stop bits, no parity
DL11-A may be used with DEC software
- DL11-C Characteristics:** Same as DL11, except odd or even parity available. (DL11-C offers a wider range of Baud rates and stop bit combinations than DL11-A. However, these do not apply to the LA30-C.)
- Maximum Cable Length:** 456m (1500 ft). Shielded twisted pair, 22-gauge, such as Belden No. 8777, should be used

SERIAL LA30 AS LOCAL OR CONSOLE DEVICE (Cont)

Using DM11 16-Terminal Interface

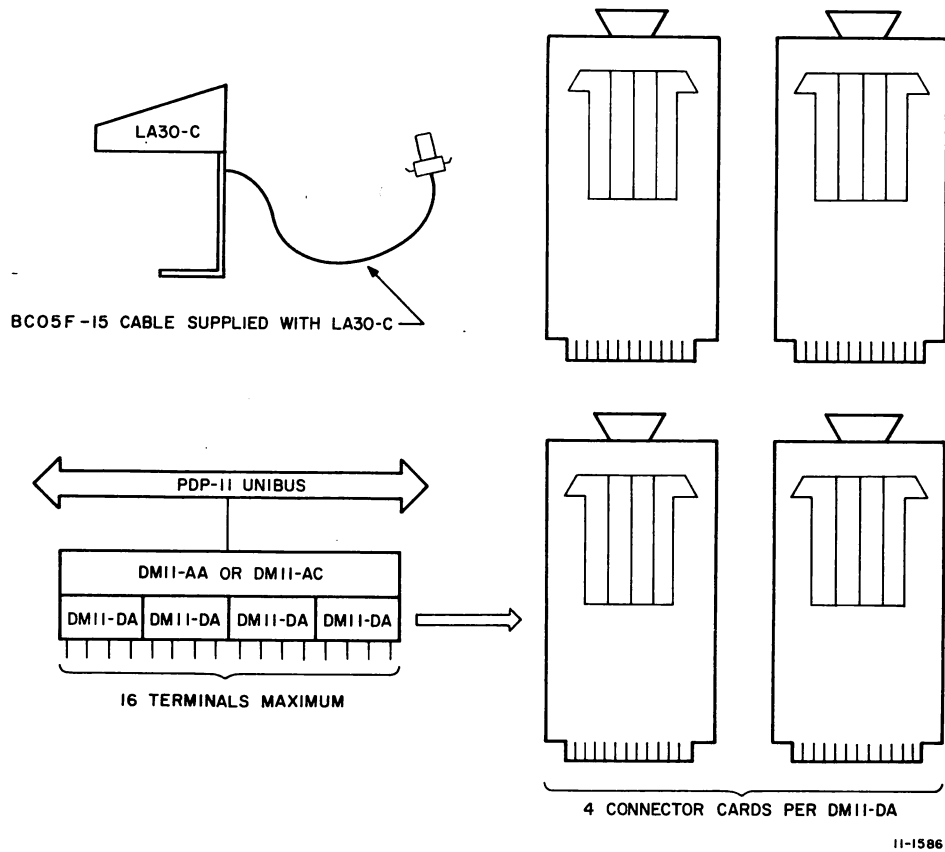

Notes:

DM11-AA is used for 115V, 60 Hz.

DM11-AC is used for 230V, 50 Hz.

Four DM11-DA 20 mA line adapters can be used with one DM11-AA or -AC.

Each DM11-DA can handle up to four LA30-C terminals.

All terminals must use the same Baud rate.

LA30-C and other terminals may be connected to the same DM11; however, the same Baud rate must be used. 20 mA and EIA terminals may be connected to the same DM11, but each group of four lines must be identical.

Baud rate must be specified when ordering the DM11. The order must also specify proper character length (8 bits) and proper number of stop bits (2).

Maximum distance between LA30-C and DM11 is 456m (1500 ft).

SERIAL LA30 AS LOCAL OR CONSOLE DEVICE (Cont)

Using DJ11 and DH11 16-Terminal Interfaces

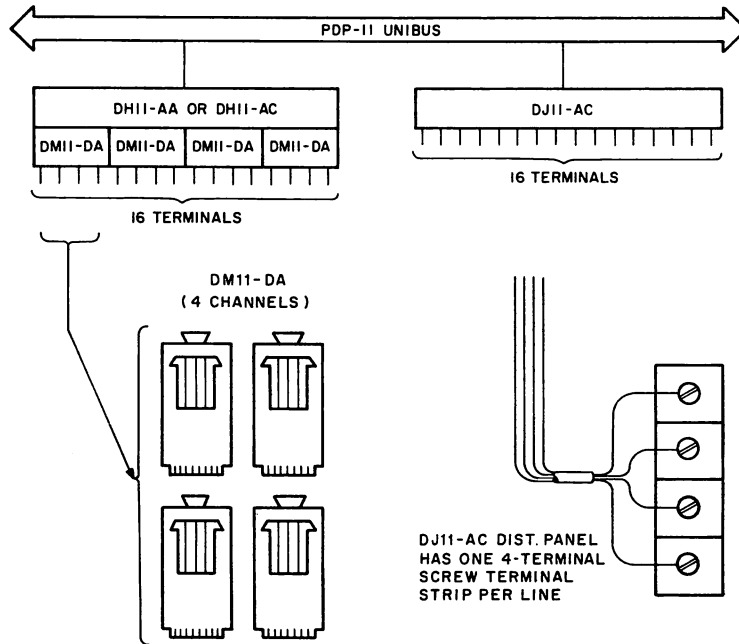

11-1591

Notes:

DH11-AA is used for 115V, 60 Hz.

DH11-AC is used for 230V, 50 Hz.

Four DM11-DA 20 mA line adapters can be used with one DH11-AA or -AC.

DJ11-AC contains line adapters.

Each DM11-DA can handle up to four LA30 terminals.

Baud rate may be varied as follows:

DH11 – Baud rate is individually program-selectable for each line.

DJ11 – Same Baud rate for each group of four lines, strap-selectable.

LA30 and other terminals may be connected to the same DH11 or DJ11. 20 mA and EIA terminals may be mixed on the same DH11 on an individual line basis. All terminals connected to a single DJ11 must be of the same type (20 mA or EIA).

Maximum distance between LA30-C and DH11 or DJ11 is 456m (1500 ft).

LA30-C AS REMOTE DEVICE

When selecting an LA30 for remote use, the LA30-E is the appropriate model because it includes EIA-level conversion and EIA cables.

However, an LA30-C can be modified for remote use should the need arise. Two methods for remote use of the LA30-C are:

a. **With H313A TTY-Data Set Converter**

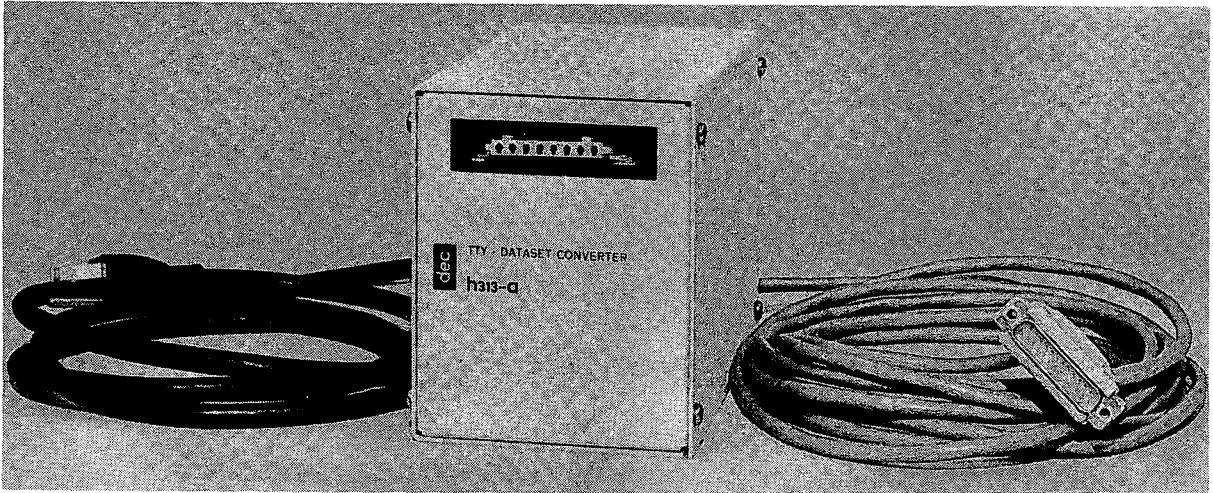

The LA30-C cable plugs directly into the H313A. A 7.6m (25 ft) cable provided with the H313A plugs into the data set.

b. **By Changing Modules Within the LA30-C**

The LA30-C contains passive, 4-wire, neutral current loop (20 mA) interface modules, with a female Amp Mate-N-Lok connector. They may be replaced with DEC DF11-A modules. The DF11-A is equipped with a 25-pin male data set connector.

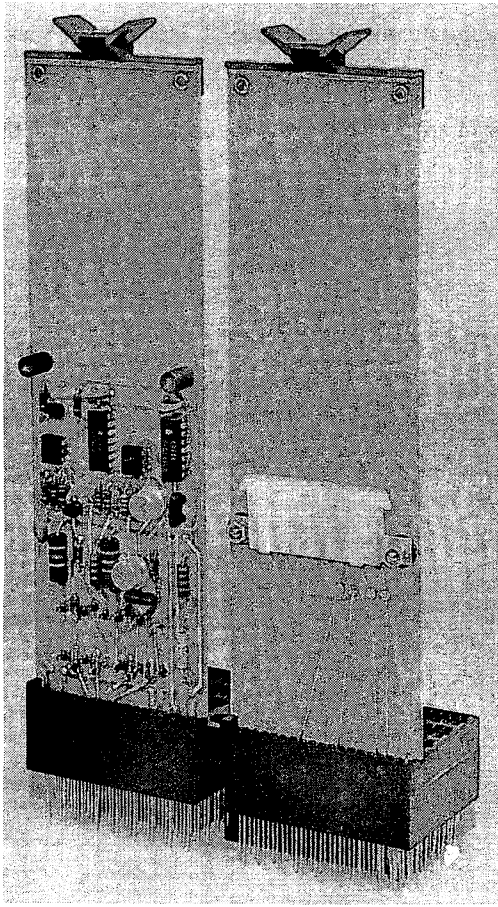

DF11-K

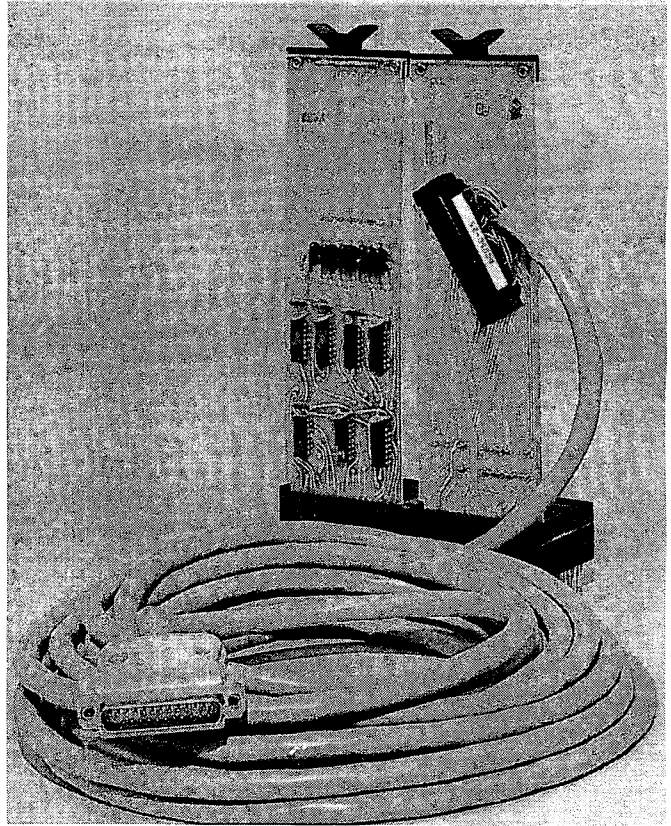

DF11-A

Note: See chart on page 2-13 for interfaces and data sets used with remote LA30s.

LA30-E AS LOCAL OR REMOTE TERMINAL

Example A (Local)

Using the: DJ11-AA
 DL11-B, -D, or -E locally
 DM11-Ax with DM11-DB or -DC
 DC11-Ax with DC11-DA
 DH11-Ax with DM11-DB or -DC

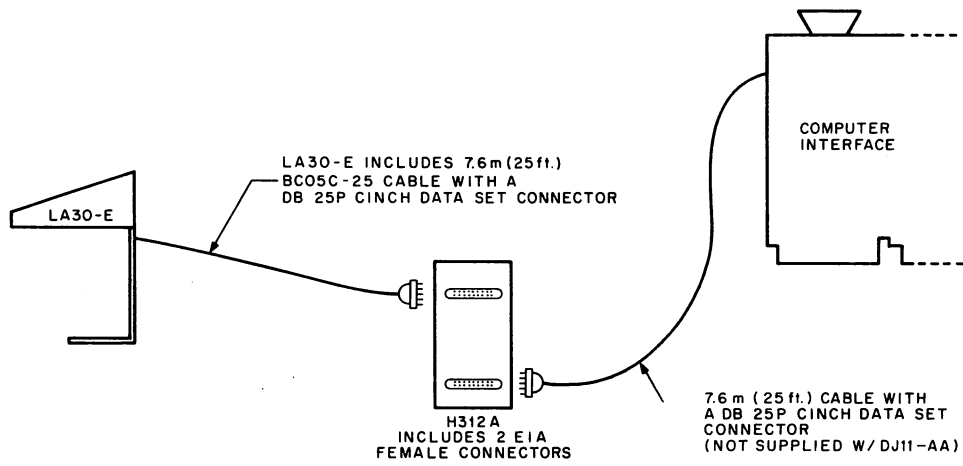

Example B (Remote)

Using the: DL11-B, -D or -E
 DM11-Ax with DM11-DB
 DM11-Ax with DM11-BB and -DC
 DC11-Ax with DC11-DA
 DH11-Ax with DM11-DB
 DH11-Ax with DM11-BB and -DC
 DJ11-AA

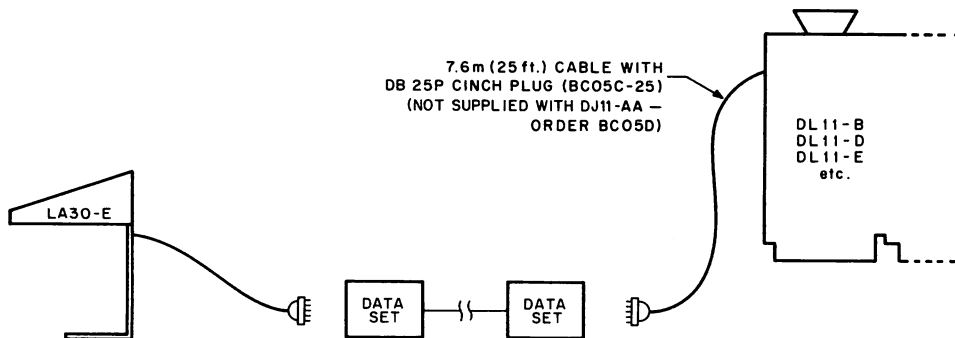

Notes:

The LA30-E can be used remotely with either a Bell 103A, 103E, 103G, 113A, or with a DEC DF01-A Acoustic Coupler.

The DL11-B and -D are asynchronous line interface units with EIA/CCITT voltage level outputs intended for local (with null modem) or remote (private wire) use via modems.

The DL11-B is limited to 8-level code with 2 stop bits; no parity checking is provided. Baud rates of 110, 150, or 300 may be selected, but they must be specified when the DL11-B is ordered.

The DL11-D is used as the DL11-B with a null modem (locally) or with modems (private line). However, it provides a choice of code levels, stop bits, and odd or even parity checking.

The DL11-E, unlike the DL11-B and -D which only control the data leads, provides full data set control (ring indicator, request to send, etc.)

Any DC11-Ax can be used along with a DC11-DA.

A DM11-Ax can be used along with a DM11-DB (data only) or with a DM11-DC and DM11-BB (full data set control).

A DH11-Ax can be used along with a DM11-DB (data only) or with a DM11-DC and DM11-BB (full data set control).

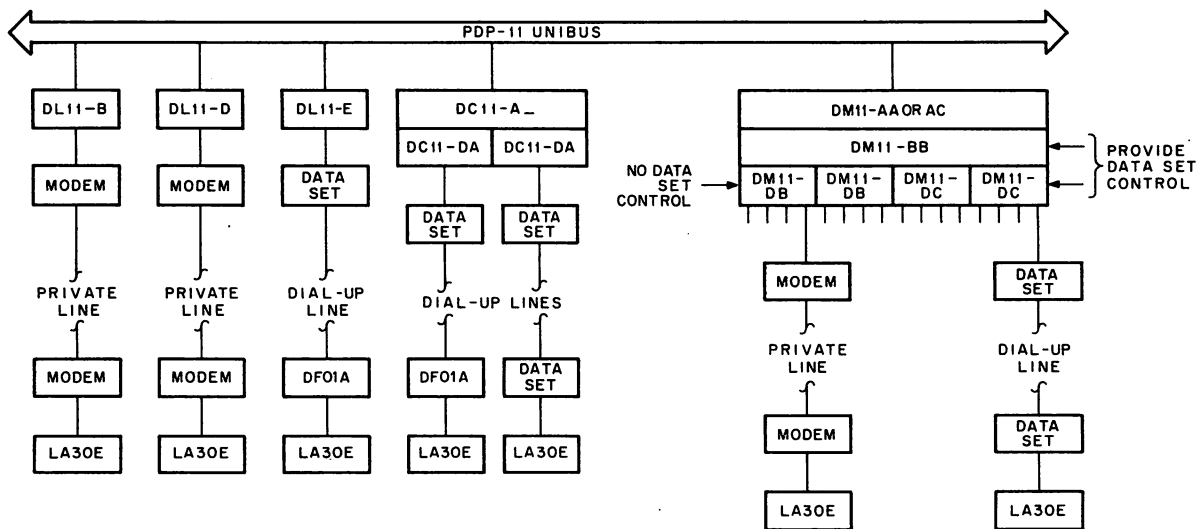

11-1588

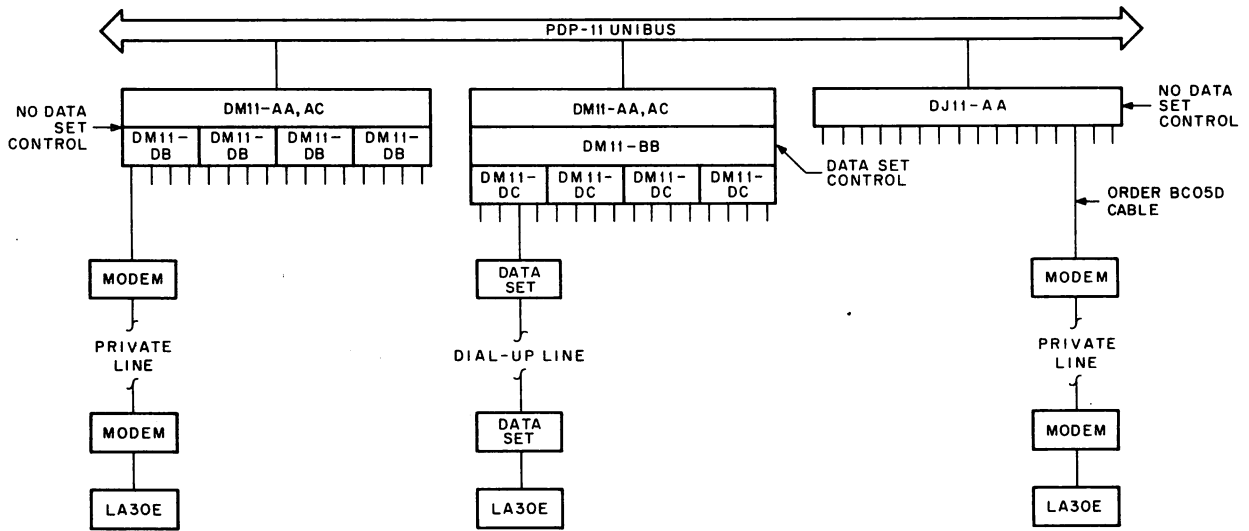

11-1600

Equipment Selection Chart for Remote Serial LA30

Select devices from any column, but *do not* cross double horizontal lines. Data rate of the computer interface selected (e.g., DL11) must match desired data rate of LA30 (e.g., 110, 150, 300 Bauds).

Terminal	Channel Interface	Channel	Channel Interface	Computer Interface	Computer
LA30-C	H313A + Bell 103F Data Set	Bell-supplied private line (customer provided data sets may be used on Bell lines, but not vice versa).	Bell 103F Data Set	DL11-B	PDP-11/10 PDP-11/20 PDP-11/40 PDP-11/45 PDP-11/50
	DL11-D				
DL11-E					
DJ11-AA					
DC11-Ax + DC11-DA					
	DF11-BA Integral Modem				
LA30-E	Bell 103F Data Set		Bell 103F Data Set + DM11-DB	DM11-AA,AC DM11-AA,AC	
	DF11-BA Integral Modem + Bell CDT Data Access Arrangement		DF11-BB Integral Modem + Bell CDT Data Access Arrangement	DM11-Ax DH11-Ax	
				DL11-x + DD11 System Unit	
LA30-C	H313A + Bell 103A,E,G, 113A Data Sets	DDD Network (direct distance dial)	Bell 103A,E,G, or 113B Data Set	DL11-E	PDP-11/10 PDP-11/20 PDP-11/40 PDP-11/45 PDP-11/50
	DC11-Ax + DC11-DA DJ11-AA (no data set control)				
	DF11-BA Integral Modem + Bell CDT Data Access Arrangement		Bell 103A,E,G 113B Data Set + DM11-DB	DM11-AA,AC DH11-AA,AC (no data set control)	
	H313A + DF01A Acoustic Coupler				
LA30-E	Bell 103A,E,G, 113A Data Set		Bell 103A,E,G 113B Data Set + DM11-DC	DM11-AA,AC + DM11-BB DH11-AA,AC + DM11-BB	
	DF11-BA + Bell CDT Data Access Arrangement		DF11-BB + Bell CBS Data Access Arrangement	DM11-AA,AC + DM11-BB DH11-AA,AC + DM11-BB	
	DF01-A Acoustic Coupler				

VT05 ALPHANUMERIC DISPLAYS

VT05 TERMINAL CHARACTERISTICS

The VT05 is intended as a direct teletypewriter replacement and has such advantages as high data transfer rates, EIA or 20 mA current loop interfacing, and easy maintenance.

General

Screen: 1440 characters (20 rows, 72 characters each)

Character Size: 1.2 cm (0.22 in.) high X 0.25 cm (0.1 in.) wide

Characters Displayed: 63 upper case (5 X 7 dot matrices)

Cursor: Blinking nonerasable (home, up, down, left, right)

Keyboard: Choice of 64-characters, no parity
96-characters, no parity
64-characters, parity
96-characters, parity

Data Communications

Baud Rates: 110, 150, 300, 600, 1200, 2400 Bauds and split speeds (switch selectable)

Code: ASCII X3.4 1968
8-Level, 2 stop bits (see notes following)

PDP-11 Interfaces: DL11 (single line)
DC11 (dual line)
DM11 (up to 16 lines)
DH11 (up to 16 lines)
DJ11 (up to 16 lines)

Applicable DEC Devices: DF01-A Acoustic Coupler
H312A Null Modem

Applicable Data Sets: Bell 103A, E, F, G; 113A, B; 202C, D, E

Cables: TTY loop 20 mA – 7.6 m (25 ft) (DEC No. 7008519 supplied with VT05-B)*
EIA – BC05D-10 ft } optional
BC05D-25 ft }

Notes:

At 110 Bauds: 1 start bit, 7 data bits + 1 parity bit, 2 stop bits.

At other rates: 1 start bit, 7 data bits + 1 parity bit, 1 stop bit.

The parity bit can optionally be set at "mark" for no parity (see order numbers).

DEC interfaces strapped for two stop bits will also accommodate one stop bit (transmit only).

*This cable looks like the BC05F cable supplied with the LA30-Cx, but is neither identical nor interchangeable.

Environmental/Physical

Temperature: 10°C – 43°C (50°F – 110°F)

Humidity: 8–90% non-condensing

Height: 30.4 cm (12 in.)

Depth: 76.2 cm (30 in.)

Width: 46.9 cm (18 1/2 in.)

Weight: 22 kg (55 lb)

VT05 Models

Model			Interfaces
VT05A	– XX	110, 150, 300 Bauds	DL11 DC11 DM11 DH11 DJ11
VT05B	– XX	110, 150, 300, 600 1200, 2400 150/2400, 110/2400 150/1200, 110/1200 Bauds	DL11 DC11 DM11 DJ11 DH11
	AX	64 character keyboard, no parity	
	BX	96 character keyboard, no parity	
	CX	64 character keyboard, with parity	
	DX	96 character keyboard, with parity	
	A	115V, 60 Hz	
	B	230V, 60 Hz	
	C	115V, 50 Hz	
	D	230V, 50 Hz	

VT05 USED LOCALLY (20 mA)

Using DL11-A or DL11-C

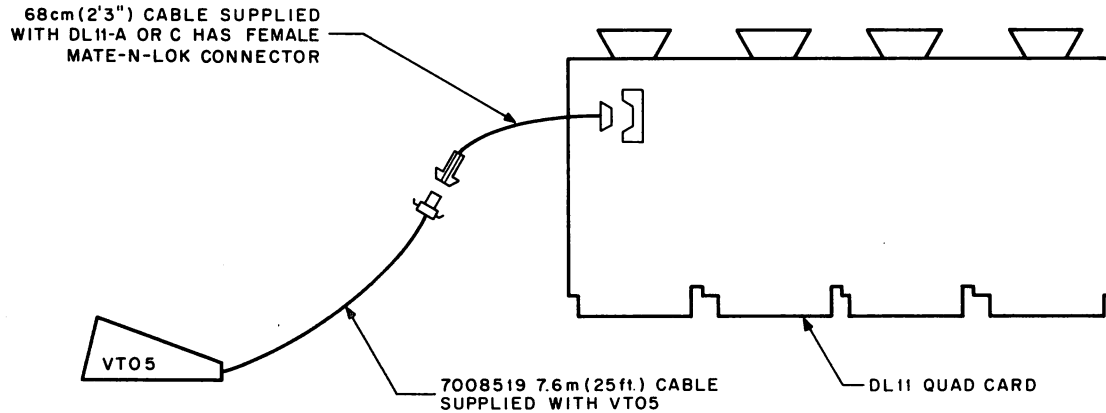

11-1581

Notes:

DL11-A: 8-level code, 2 stop bits, no parity.
Choice of 110, 150, 300, 600, 1200 or 2400 Bauds*.
No split speeds.

DL11-C: Choice of 110, 150, 300, 600, 1200, or 2400 Bauds* or split speeds* (no split speed with 110 Bauds) 8-level code*, 1 or 2 stop bits* (DL11-C provides other code and stop bit combinations; however, these do not apply to VT05).

Cable: A 7.6m (25 ft) cable, terminated with a male Amp Mate-N-Lok connector for 20 mA use is supplied with the VT05.

Distances: The VT05 can be used with a DL11-A or DL11-C at the following distances (in relatively noiseless environments):

Terminal Receiver	300 Bauds:	609m	(1500 ft)
Speeds up to:	600 Bauds:	304m	(1000 ft)
	1200 Bauds:	152m	(500 ft)
	2400 Bauds:	126m	(250 ft)

The above chart is only applicable if the VT05 transmit speed does not exceed 150 bauds.

When distances in excess of the standard cable length (7.6 m) are used, shielded twisted pair cable (such as Belden No. 8777) is recommended.

*Choice must be specified when ordering.

VT05 USED LOCALLY (20 mA) (Cont)

Using DM11-AA or -AC plus DM11-DA

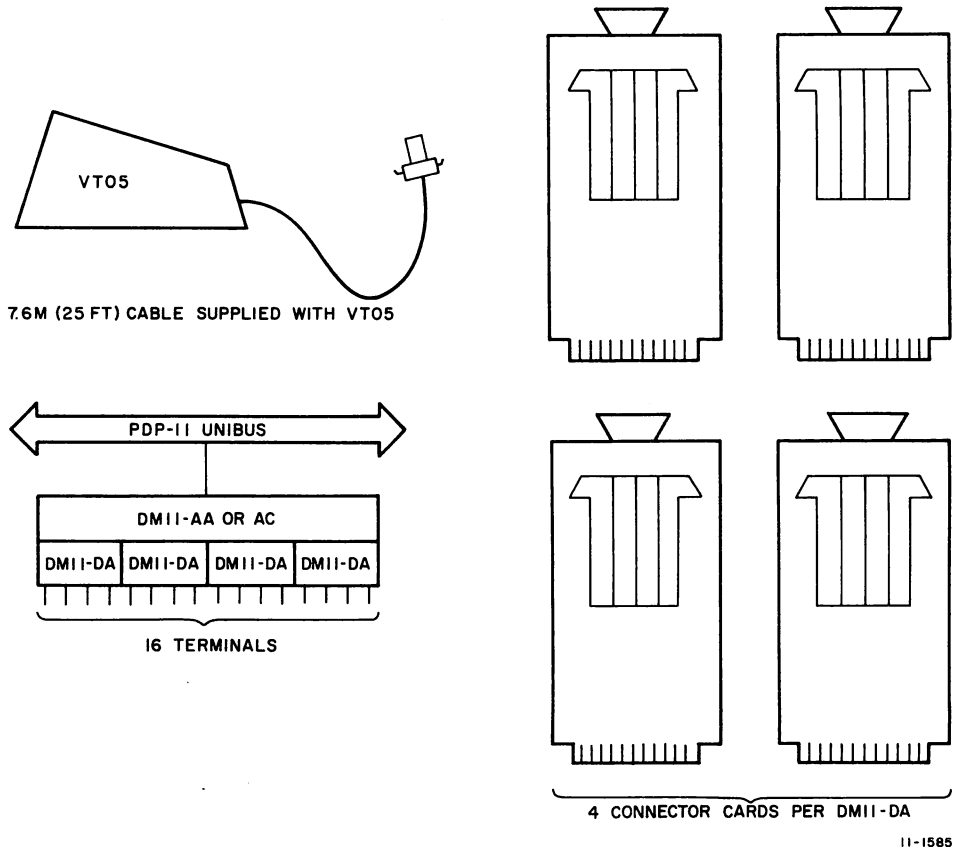

Notes:

DM11-AA is used for 115V, 60 Hz.
 DM11-AC is used for 230V, 50 Hz.

Four DM11-DA 20 mA line adapters can be used with one DM11-AA or -AC.

Each DM11-DA can handle up to four VT05 terminals.

All VT05s must use the same Baud rate (maximum DM11 Baud rate is 1200 Bauds for full 16 lines).

VT05 and other terminals may be connected to the same DM11; however, the same Baud rate must be used. 20 mA and EIA terminals may be connected to the same DM11, but each group of four lines must be identical.

Baud rate must be specified when ordering DM11. Order must also specify proper level code (8 bits) and proper number of stop bits (2).

Jumpers connecting filter capacitors on the DM11-DA interface card must be removed for VT05-B operation with DM11-DA at speeds greater than 300 Bauds.

VT05 USED LOCALLY (20 mA) (Cont)

Using DH11-AA or -AC plus DM11-DA or DJ11-AC

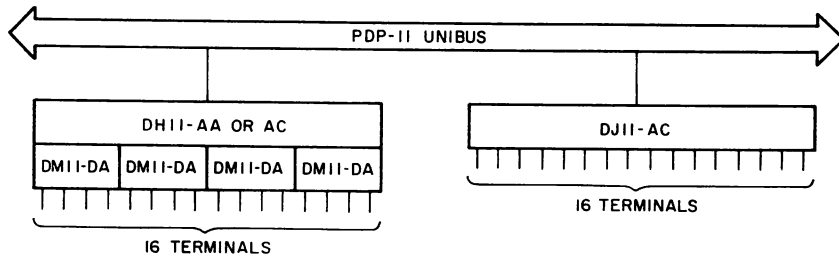

11-1590

Notes:

DH11-AA is used for 115V, 60 Hz.

DH11-AC is used for 230V, 50 Hz.

Four DM11-DA 20 mA line adapters can be used with one DH11-AA or -AC.

Each DM11-DA can handle up to four VT05 terminals.

DJ11-AC is complete with line adapters, but cables are not supplied.

Each group of four VT05s must use the same Baud rate when connected to the DJ11.

Each line of DH11 is program selectable for speed and character parameters.

VT05 and other terminals may be connected to the same DH11 or DJ11.

For the DJ11, all terminals must be of the same interface type (20 mA or EIA). For the DH11, channel types may be intermixed in four line groups.

VT05 USED LOCALLY (EIA)

Using DL11-B or DL11-D

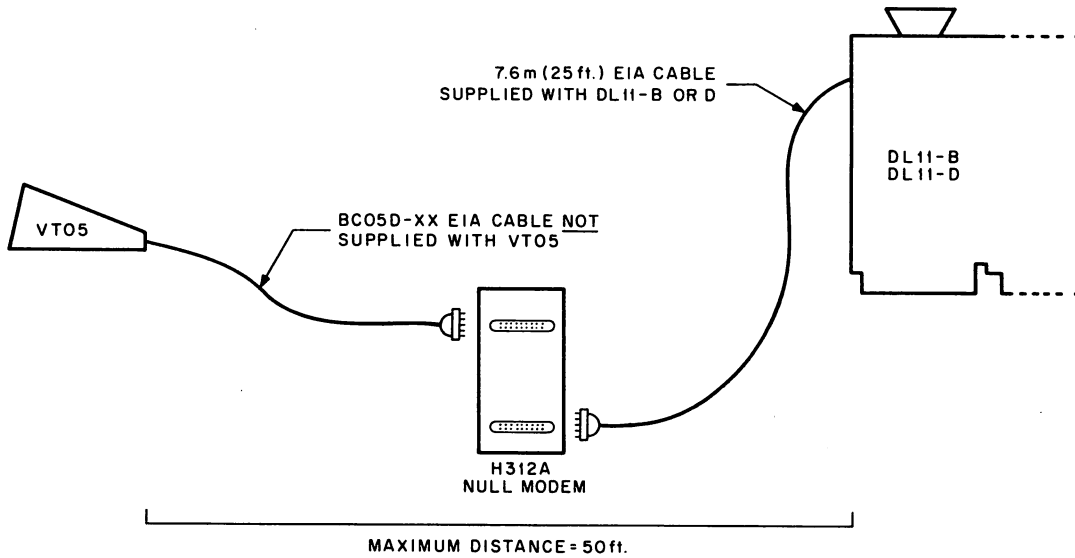

11-1594

Notes:

EIA cable for VT05-B *must* be ordered separately (order BC05D-25 cable).

The H312A simulates two back-to-back Bell 103A2 data sets. It contains two female EIA connectors.

DL11-B: Includes 7.6m (25 ft) cable (BC05C-25) with DB 25P Cinch male data set connector
8-level code, 2 stop bits, no parity
Choice of Baud rates

DL11-D: Includes BC05C-25 cable
Choice of parity or no parity
Choice of codes and stop bits

Maximum distance between the VT05 and the interface is 15.2m (50 ft).

VT05 USED REMOTELY (EIA)

Using DL11-D or DL11-E

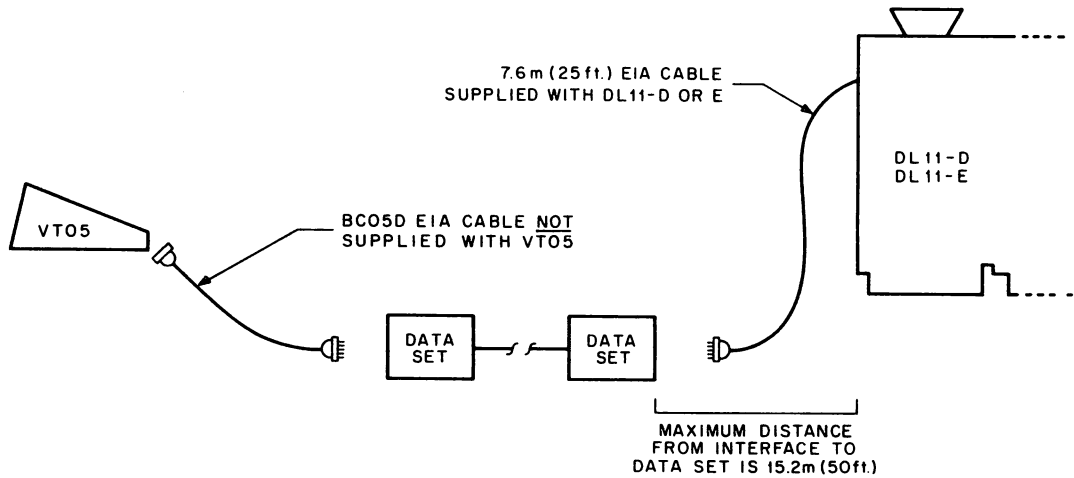

11-1593

Notes:

The DL11-D and DL11-E are similar in that they are equipped with a 7.6m (25 ft) EIA cable and provide a choice of Baud rates (including split speeds), stop codes, level codes, and parity or no parity.

The DL11-D is used with private lines and modems and only provides signalling on the data leads.

The DL11-E is used with dial network lines and data sets and consequently provides full data set control (ring indicator, request to send, etc.).

A BC05D-10 or BC05D-25 cable must be purchased for connecting the VT05 to a modem or data set.

VT05 USED REMOTELY (EIA) (Cont)

Using the DC11-Ax and DC11-DA

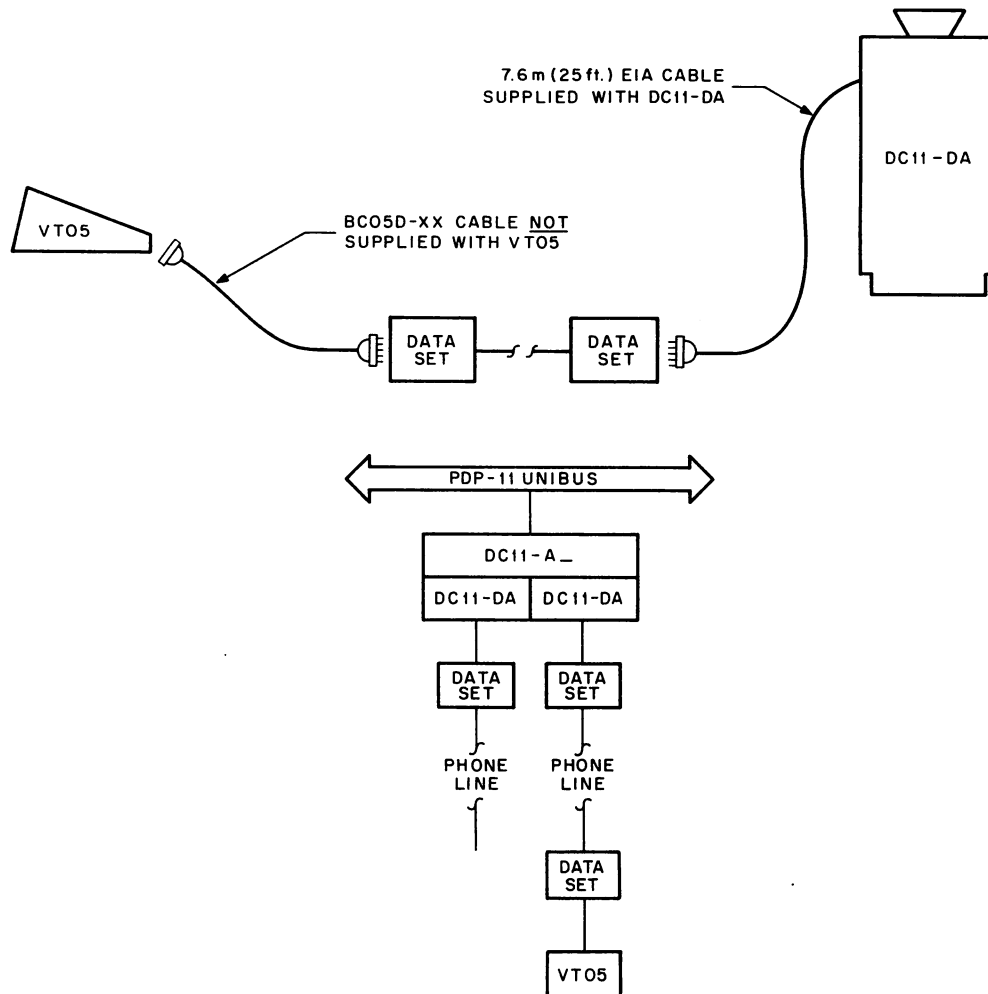

11-1592

Notes:

A DC11-Ax and DC11-DA must be used.

One serial asynchronous line may be connected to one DC11-DA. Two DC11-DAs may be connected to one DC11-Ax.

Baud rates, character size, and stop code length may be modified by the software.

The DC11-DA includes a 7.6m (25 ft) EIA cable.

DC11-DA permits connection to Bell 103A, 103E, 103F, 103G, 113A, 113B and 202, or equivalent.

VT05 USED REMOTELY (EIA) (Cont)

Using DM11-Ax with DM11-DB or DM11-Ax with DM11-BB and DM11-DC

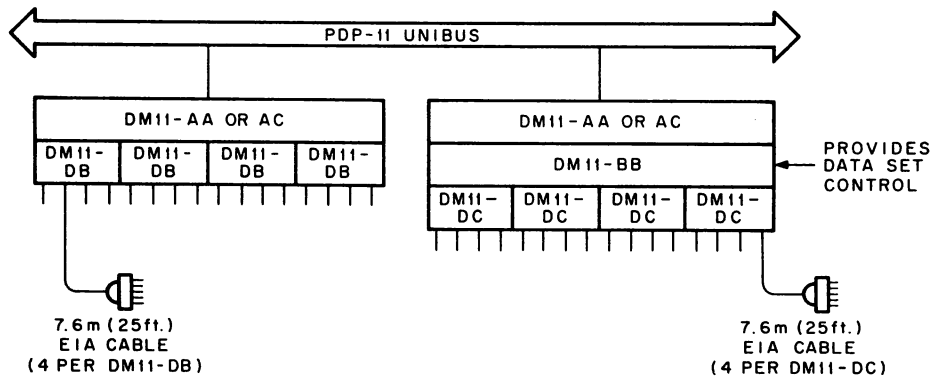

11-1589

Notes:

Rates up to 300 Bauds can be specified.

Character size and stop code must be specified.

Parity is checked/furnished by the program.

The DM11-AA or -AC and DM11-DB are used with modems and private lines.

The DM11-AA or -AC, DM11-BB, and DM11-DC are used with data sets and dial-up lines.

Each DM11-DB and DM11-DC is equipped with 7.6m (25 ft) EIA cables.

VT05 USED REMOTELY (EIA) (Cont)

Using DM11 and DJ11

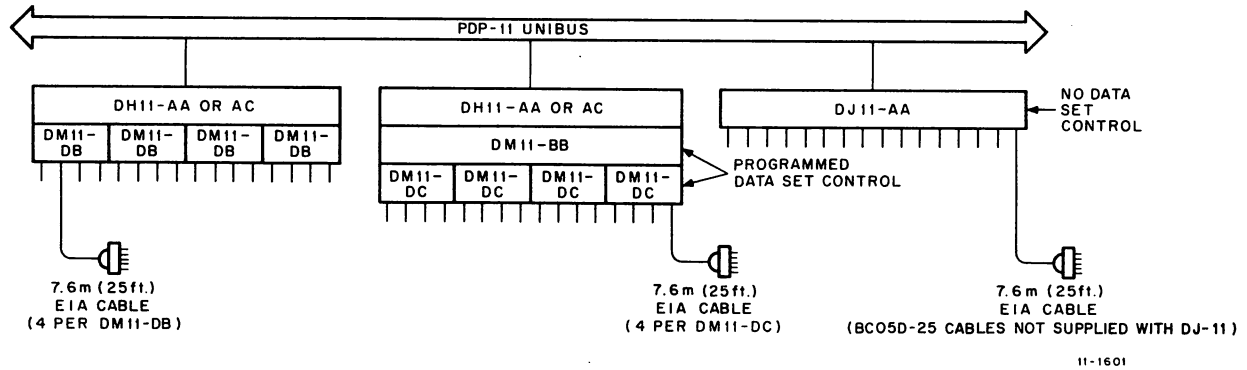

Notes:

The DH11-AA or -AC with DM11-DB is used with modems and private lines as is the DJ11-AA.

The DH11-AA or -AC with DM11-BB and DM11-DC is used with data sets and dial-up lines.

Equipment Selection Chart for Remote VT05

Select one device from each column, but *do not* cross double horizontal lines. Data rate of computer interface selected (e.g., DL11) must match desired data rate of VT05. See *DECcomm Modems and Data Sets Guide* for further information on modems/data sets.

Terminal	Channel Interface	Channel	Channel Interface	Computer Interface	Computer	
VT05-B + BC05D Cable	Bell 103F Data Set (up to 300 Bauds)	Bell-supplied private line (customer provided data sets may be used on Bell lines, but not vice versa)	Bell 103F Data Set	DL11-B	PDP-11/10 PDP-11/20 PDP-11/40 PDP-11/45 PDP-11/50	
				DL11-D		
				DL11-E		
				DJ11-AA + BC05D		
				DC11-Ax + DC11-DA		
			Bell 103F Data Set + DM11-DB	DM11-AA,AC DH11-Ax		
			DF11-BB + Integral Modem Bell CDT Data Access Arrangement	DM11-AA,AC DH11-AA,AC DL11-x + DD11 System Unit DC11-Ax + DC11-DA		
			Bell 103A,E,G 113A Data Set (up to 300 Bauds)	DDD Network (direct distance dial)	Bell 103A,E,G or 113B Data Set	DC11-Ax + DC11-DA DJ11-AA (no data set control)
						Bell 103A,E,G 113B Data Set + DM11-DB
					Bell 103A,E,G 113B Data Set + DM11-DC	DM11-AA,AC + DM11-BB DH11-Ax + DM11-BB
DF11-BB Integral Modem + Bell CBS Data Access Arrangement	DM11-AA,AC + DM11-BB DH11-AA,AC + DM11-BB					

DEC-SUPPLIED TELETYPES

INTERFACING TELETYPES TO PDP-11 SYSTEMS

General Teletype Characteristics

Print Speeds: 10 characters/second
Line Spacing: 10 characters/inch
Line Length: 72 characters
Paper Tape Read
or Punch Speed: 10 characters/second

Data Communications

Code: Modified 8-level USASCII* + 2 stop bits
PDP-11 Interfaces: DM11-AA,-AC, DM11-DA
DL11-A
DH11-AA, -AC
DJ11-AC
Applicable DEC Devices: DF01 Acoustic Coupler
H313A, TTY to data set converter
Applicable Data Sets: Bell 113A, B, (DDD) or equivalent
Bell 103A, E, G, (DDD) or equivalent
Bell 103F (private line) or equivalent

MODEL NUMBERS

LT33-DC	ASR-33	115V, 60 Hz
LT33-DD	ASR-33	240V, 50 Hz
LT33-CC	KSR-33	115V, 60 Hz
LT33-CD	KSR-33	230V, 50 Hz
LT35-DC	ASR-35	115V, 60 Hz
LT35-DD	ASR-35	230V, 50 Hz
LT35-CC	KSR-35	230V, 60 Hz
LT35-CD	KSR-35	230V, 50 Hz
LT33-HA	ASR-33	115V, 60 Hz
LT33-HB	ASR-33	230V, 50 Hz

ASR: Automatic Send/Receiver - includes keyboard and paper-tape reader/punch.

KSR: Keyboard only send/receive.

* Modification consists of retaining left-arrow and up-arrow characters of original ASCII standard.

Notes:

Teletype Corporation produces a variety of different models, with virtually endless options, for almost every conceivable application. DEC provides, as standard, only two units that are economically and technically suited for normal uses with PDP computers.

DEC makes certain modifications to Teletypes, the most significant of these is the modification involving the paper-tape reader control. This modification is made particularly for applications where the Teletype is near the computer to reduce program complexity.

DEC Teletypes are modified for hardwired reader control from the computer. These terminals have the reader-run controls brought back to the computer terminal interface hardware with an additional pair of wires.

Models LT33-Dx and LT35-Dx have the reader-run modification and are intended for local use. They can be used remotely; however, the control contacts for the reader run relay must be shorted and the paper-tape reader must be operated manually (i.e., not under computer control). If the remote use of an LT33-Dx or LT35-Dx becomes necessary, then assistance should be solicited from DEC Field Service.

The LT33-H can be used remotely without affecting the use of the paper-tape reader.

DEC Teletypes use 20 mA current and are supplied with a 12-ft cable terminating with a male Mate-N-Lok connector.

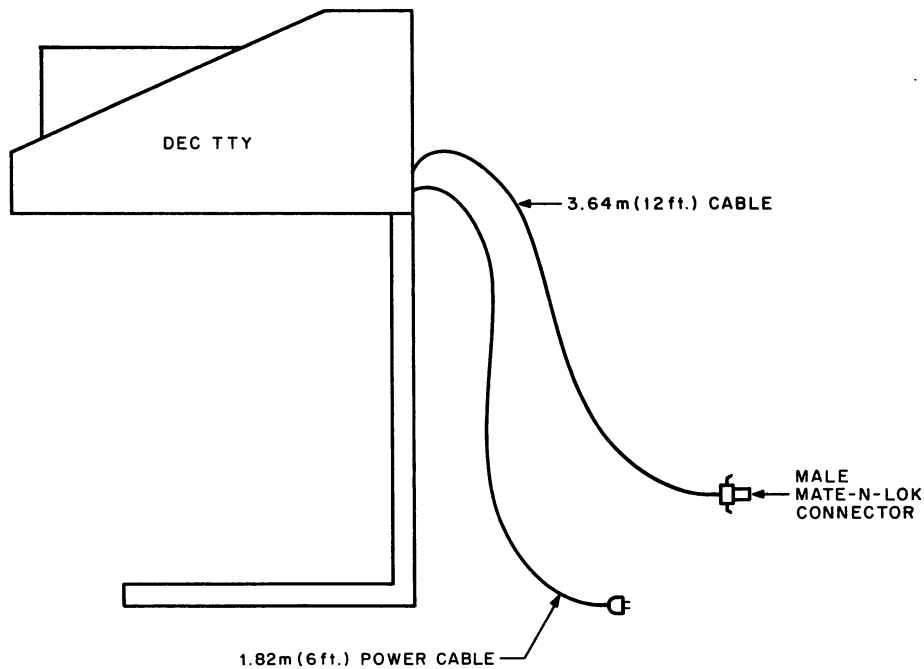

11-1584

REMOTE USE OF DEC-SUPPLIED TELETYPES

The H313A Teletype to Data Set Converter is available for connecting DEC Teletypes to modems and data sets; the DEC DF01 Acoustic Coupler can be used also.

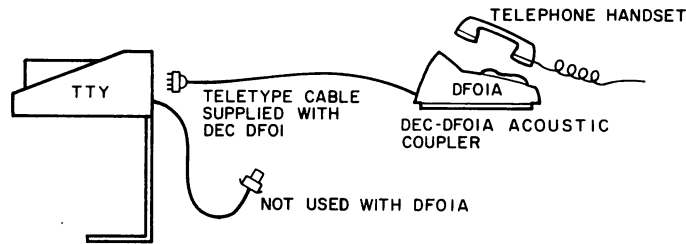

11-1598

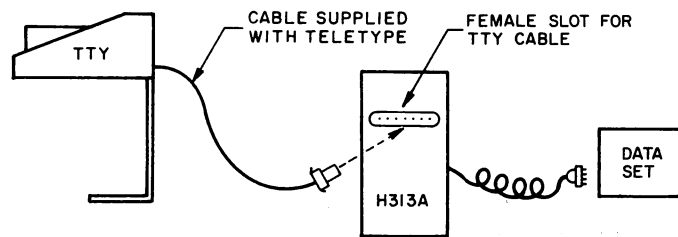

11-1599

When DEC-supplied Teletypes are used remotely the following PDP-11 serial line interfaces can be used:

- | | | | |
|--------------|----------------------------------------------------------------------|----|----------------------------------------------|
| DL11 Series: | DL11-B (private line) | — | specify 110 Bauds |
| | DL11-E (dial-up-line) | — | specify 8-level code, 2 stop bits, 110 Bauds |
| DC11 Series: | DC11-AA with DC11-DA | — | |
| DM11 Series: | DM11-AA,AC with DM11-DB (private line) | — | specify 110 Baud, 8-level code, 2 stop bits |
| | | or | |
| | DM11-Ax with DM11-BB and DM11-DC (includes full dataset control) | — | specify 110 Bauds 8-level code, 2 stop bits |
| DH11 Series: | DH11-AA,AC — with DM11-DB (private line) | | |
| | | or | |
| | DH11-AA, AC with DM11-BB and DM11-DC (includes full dataset control) | | |
| DJ11 Series: | DJ11-AA (private line) | | |

LOCAL USE OF DEC-SUPPLIED TELETYPES

Using DL11-A Interface

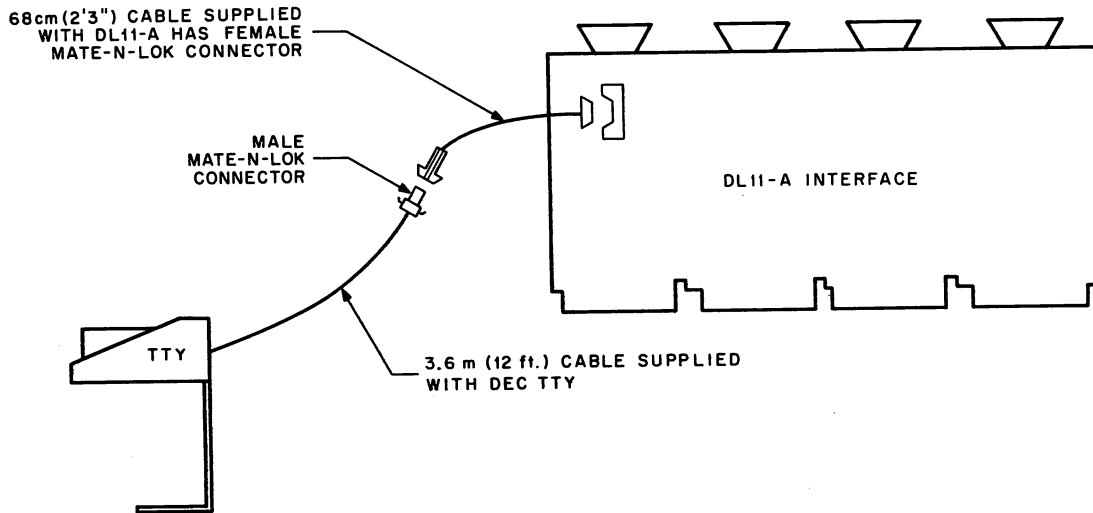

11-1580

Use DL11-A interfaces for local use of DEC-supplied Teletypes. Eight-level code, 2 stop bits and no parity are standard with the DL11-A. However, 110 Bauds must be specified.

Maximum distance between terminal and PDP-11 is 1500 ft in relatively noiseless environments. Shielded twisted pair cable is recommended (Belden No. 8777).

LOCAL USE OF DEC-SUPPLIED TELETYPES (Cont)

Using DM11-AA or -AC with DM11-DA

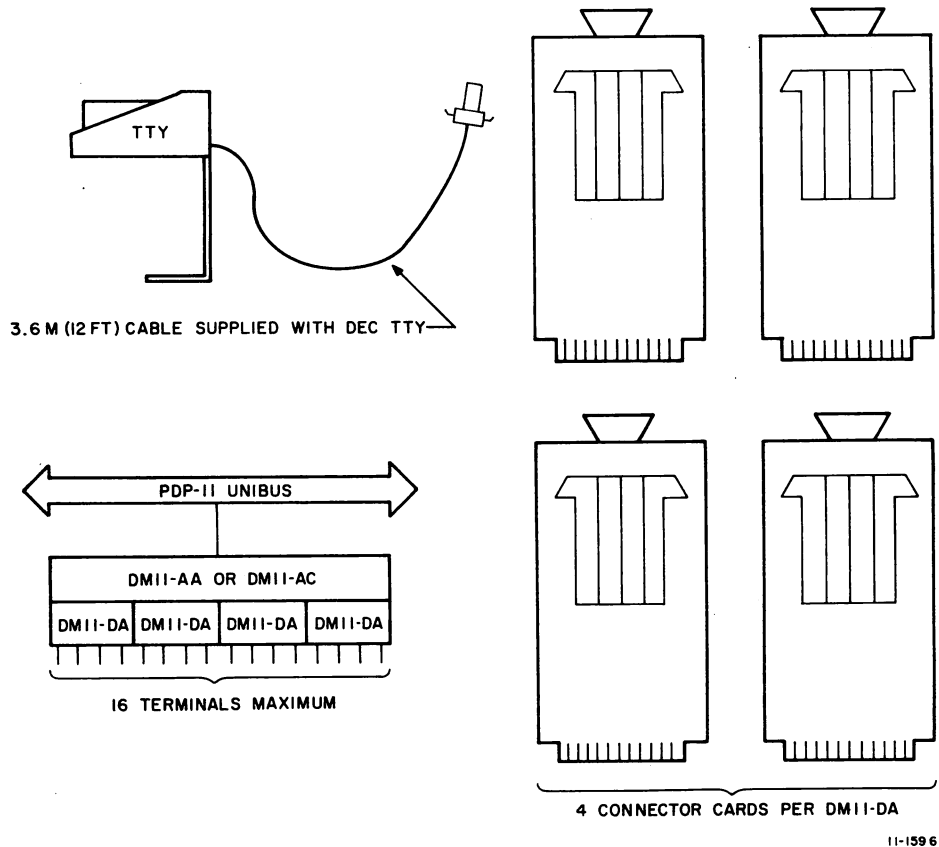

Notes:

DM11-AA is used for 115V, 60 Hz.

DM11-AC is used for 230V, 50 Hz.

Four DM11-DA 20 mA line adapters can be used with one DM11-AA or -AC.

Each DM11-DA can handle up to four terminals.

All terminals must use the same Baud rate.

TTY and other terminals can be connected to the same DM11; however, the same Baud rate must be used. 20 mA and EIA terminals can be intermixed on a DM11.

Baud rate (110), character length (8 bits), and stop bits (2), must be specified when ordering the DM11.

LOCAL USE OF DEC-SUPPLIED TELETYPES (Cont)

Using DH11 or DJ11

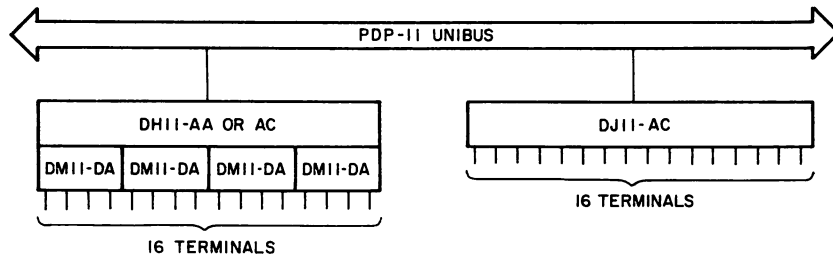

DM11-DA CONTAINS
MODULES WITH FEMALE MATE-
N-LOCK CONNECTOR FOR CONNECTION
WITH TELETYPE CABLE

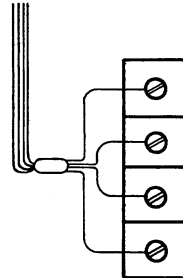
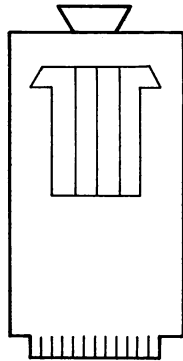

11-1587

Notes:

DH11-AA is used for 115V, 60 Hz.

DH11-AC is used for 230V, 50 Hz.

Four DM11-DA 20 mA line adapters can be used with one DH11-AA or -AC.

Each DM11-DA can handle four terminals. The DJ11-AC can accommodate 16 terminals.

Each group of four terminals on the DM11-AA (i.e., DM11-DA) or DH11 must use the same Baud rates. TTY and other types of terminals can be used. Each group of four must be identical (either EIA or 20 mA).

Terminals may be located up to 456m (1500 ft) from the interface.

Equipment Selection Chart for Remote Use of DEC-Supplied Teletypes

Select one device from each column, but *do not* cross *double* horizontal lines. Data rate of computer interface selected must match desired data rate of Teletype (e.g., 110 Bauds).

Terminal	Channel Interface	Channel	Channel Interface	Computer Interface	Computer
*LT33 or 35	H313A + Bell 103F Data Set	Bell-supplied private line (customer provided data sets may be used on Bell lines, but not vice versa)	Bell 103F Data Set	DL11-B	PDP-11/10 PDP-11/20 PDP-11/40 PDP-11/50 PDP-11/45
				DL11-E	
				DJ11-AA + BC05D Cable	
				DC11-Ax + DC11-DA	
			Bell 103F Data Set + DM11-DB	DM11-AA,AC	
				DH11-AA,AC	
	H313A + Bell 103A,E,G 113A Data Sets	DDD Network (direct distance dial)	Bell 103A,E,G, 113B Data Set	DL11-E	PDP-11/10 PDP-11/20 PDP-11/40 PDP-11/50 PDP-11/45
				DC11-Ax + DC11-DA	
				DJ11-AA + BC05D Cable (no data set control)	
			Bell 103A,E,G, 113B Data Set + DM11-DB	DM11-AA,AC	
				DH11-AA,AC (no data set control)	
				DM11-AA,AC + DM11-BB	
H313A + DF01-A Acoustic Coupler	DDD Network (direct distance dial)	Bell 103A,E,G, 113B Data Set + DM11-DC	DH11-AA,AC + DM11-BB	PDP-11/10 PDP-11/20 PDP-11/40 PDP-11/50 PDP-11/45	
			DM11-AA,AC + DM11-BB		
			DH11-AA,AC + DM11-BB		
Bell 103A,E,G, 113A Data Set	DDD Network (direct distance dial)	DF11-BB Integral Modem + Bell CBS Data Access Arrangement	DM11-AA,AC + DM11-BB		PDP-11/10 PDP-11/20 PDP-11/40 PDP-11/50 PDP-11/45
			DH11-AA,AC + DM11-BB		
			DM11-AA,AC + DM11-BB		

* With modification. See Note Page 4-2.

