







THE DESIGN AND SPECIFICATION HEREIN ARE THE PROPERTY OF DIGITAL EQUIPMENT CORPORATION AND SHALL NOT BE REPRODUCED OR COPIED OR USED IN WHOLE OR IN PART AS THE BASIS FOR THE MANUFACTURE OR SALE OF OTHER EQUIPMENT WITHOUT PERMISSION. COPYRIGHT © 1975 DIGITAL EQUIPMENT CORPORATION

DCS M7264-0-1

PREFIX "K2" APPLIES TO ALL WDAL WMIB SIGNALS

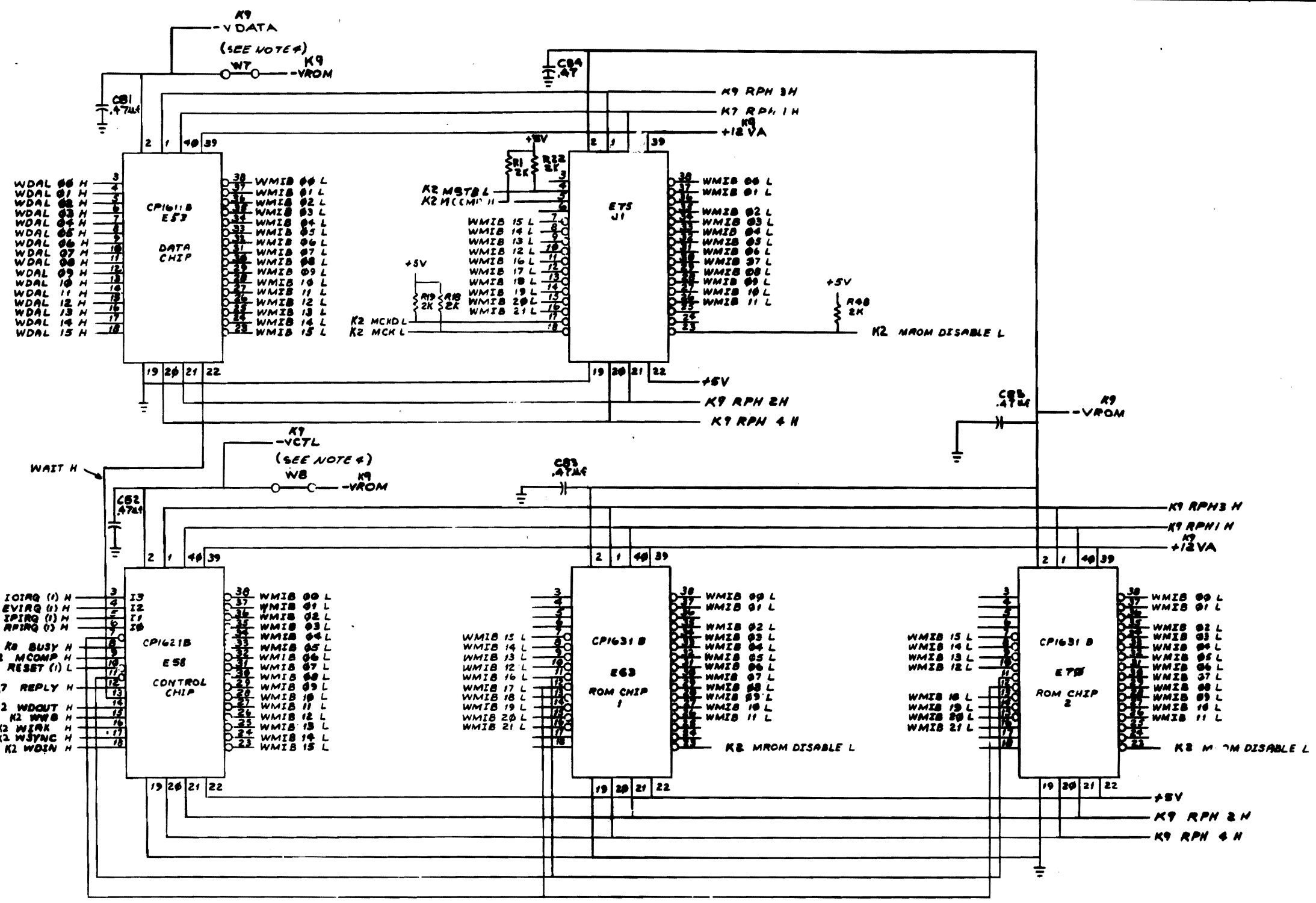

REVISIONS		
CHK	CHANGE NO.	REV

TITLE LSI-11 CPU MODULE (K2) DCS M7264-0-1  
 SCALE 1:1 SHEET 3 OF 10

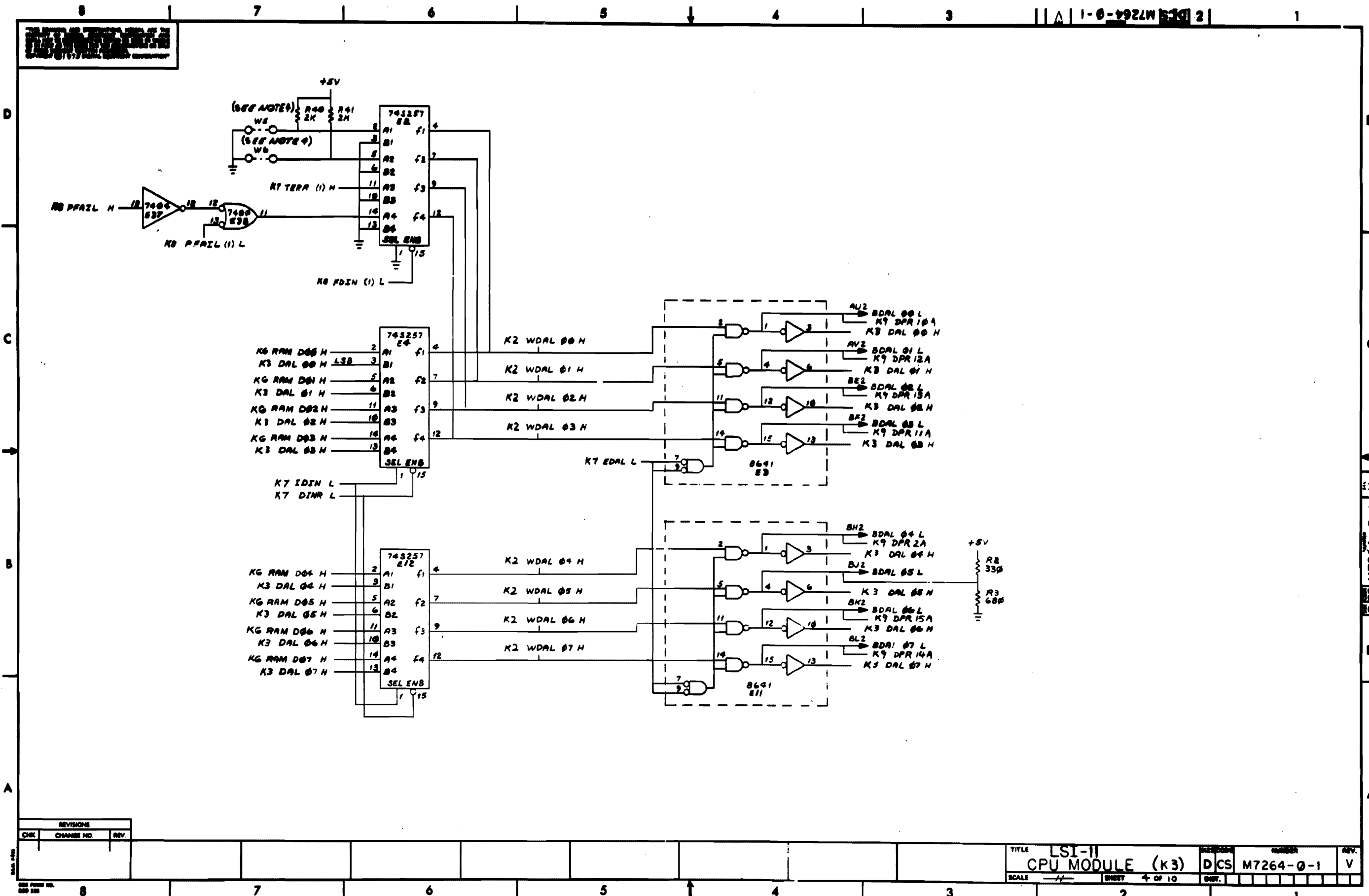

REVISIONS		
CHK	CHANGE NO.	REV.

TITLE	LSI-II CPU MODULE (K3)	REV. NO.	NUMBER	REV.
SCALE	1/1	SHEET	4 OF 10	SUB.

DCS M7264-0-1 V

THIS DRAWING AND THE INFORMATION CONTAINED HEREIN IS UNCLASSIFIED EXCEPT WHERE SHOWN OTHERWISE.

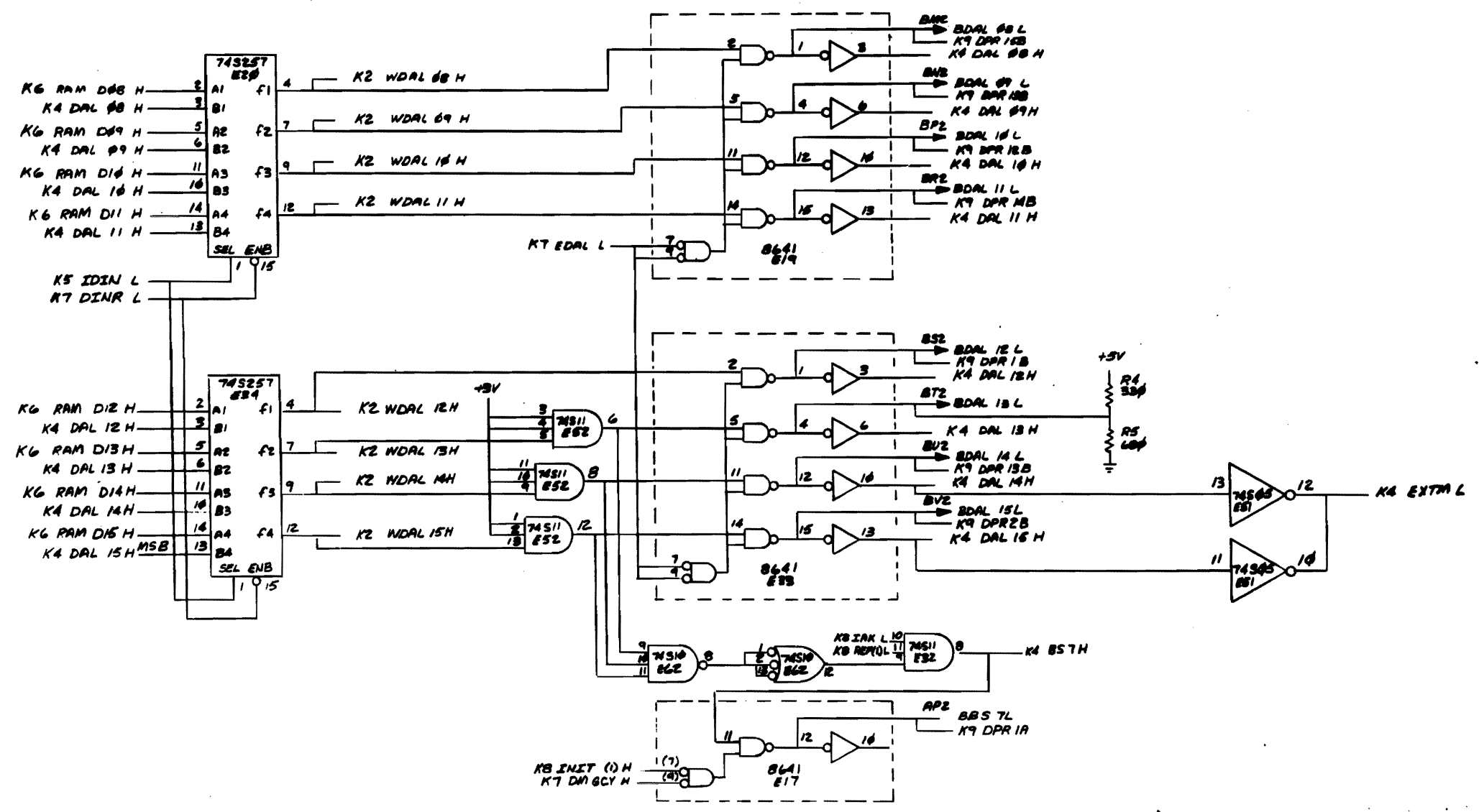

REVISIONS		
CHK	CHANGE NO.	REV.

DCS M7264-0-1 V

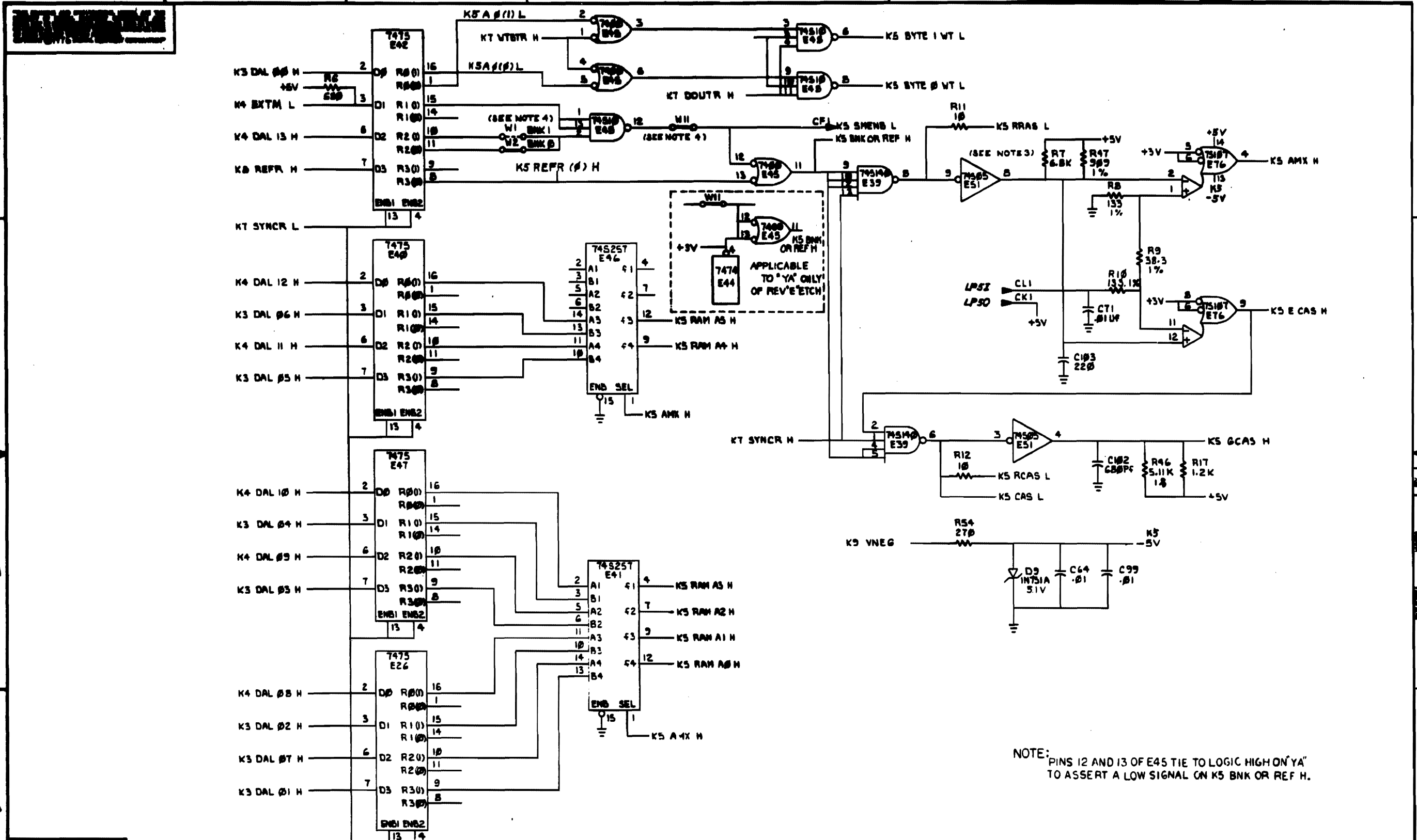

NOTE: PINS 12 AND 13 OF E45 TIE TO LOGIC HIGH ON 'YA' TO ASSERT A LOW SIGNAL ON K5 BNK OR REF H.

CIRCUIT SCHEMATIC ON THIS SHEET IS DELETED FOR "YA" VERSION

REV.	NO.	DATE	BY	CHK	APPR	NO.	REV.

TITLE	LSI-11	NUMBER	DCS	M7264-0-1	REV.	V
	CPU MODULE	(K5)				
SCALE	1:1	SHEET	5	OF	10	DWT.

DCS M7264-0-1 V

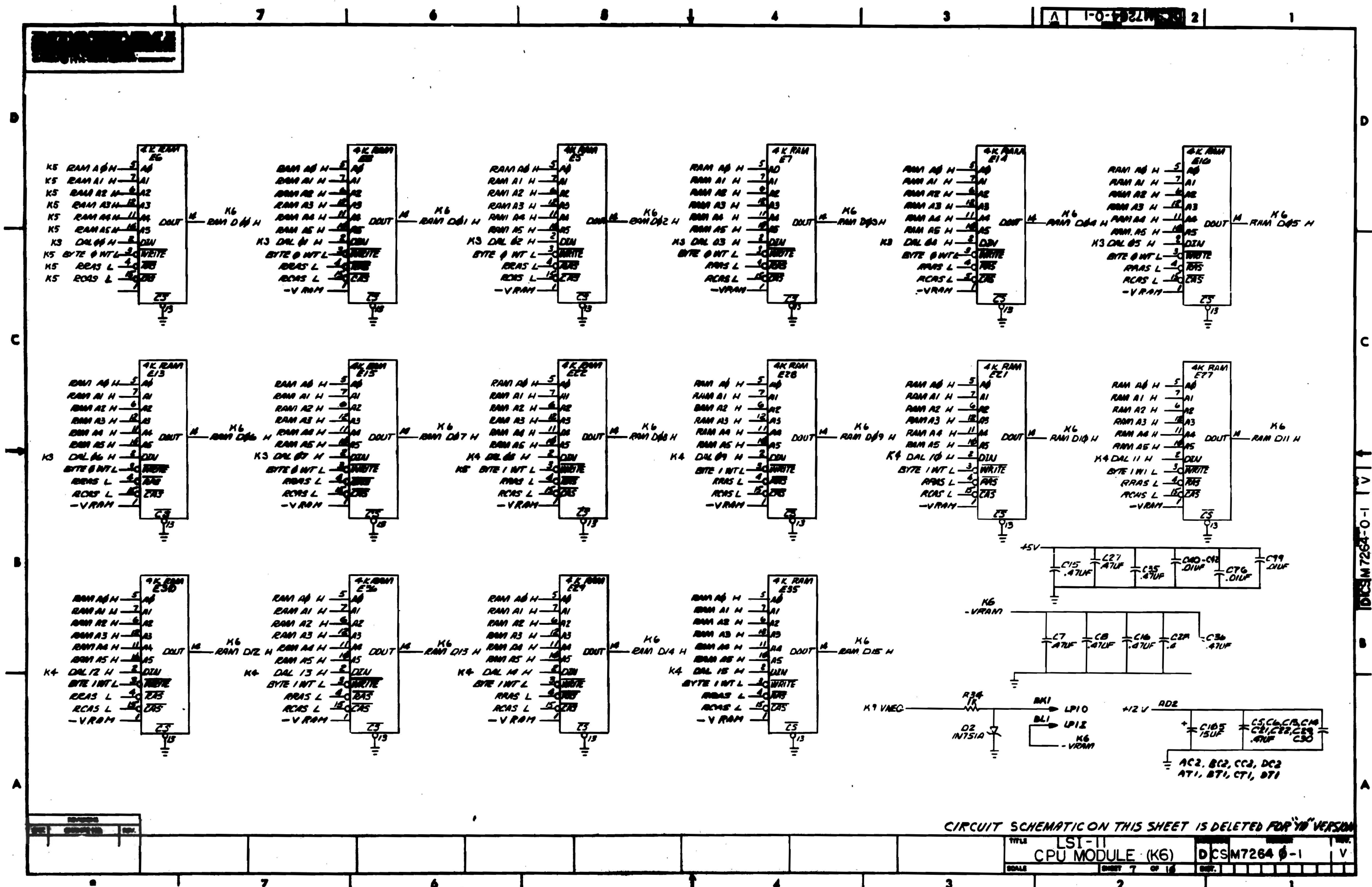

CIRCUIT SCHEMATIC ON THIS SHEET IS DELETED FOR '10' VERSION

TITLE	LSI-11 CPU MODULE (K6)	DCSM7264 0-1	V
SCALE	SHEET 7 OF 10	REV.	

DCSM 7264-0-1 V

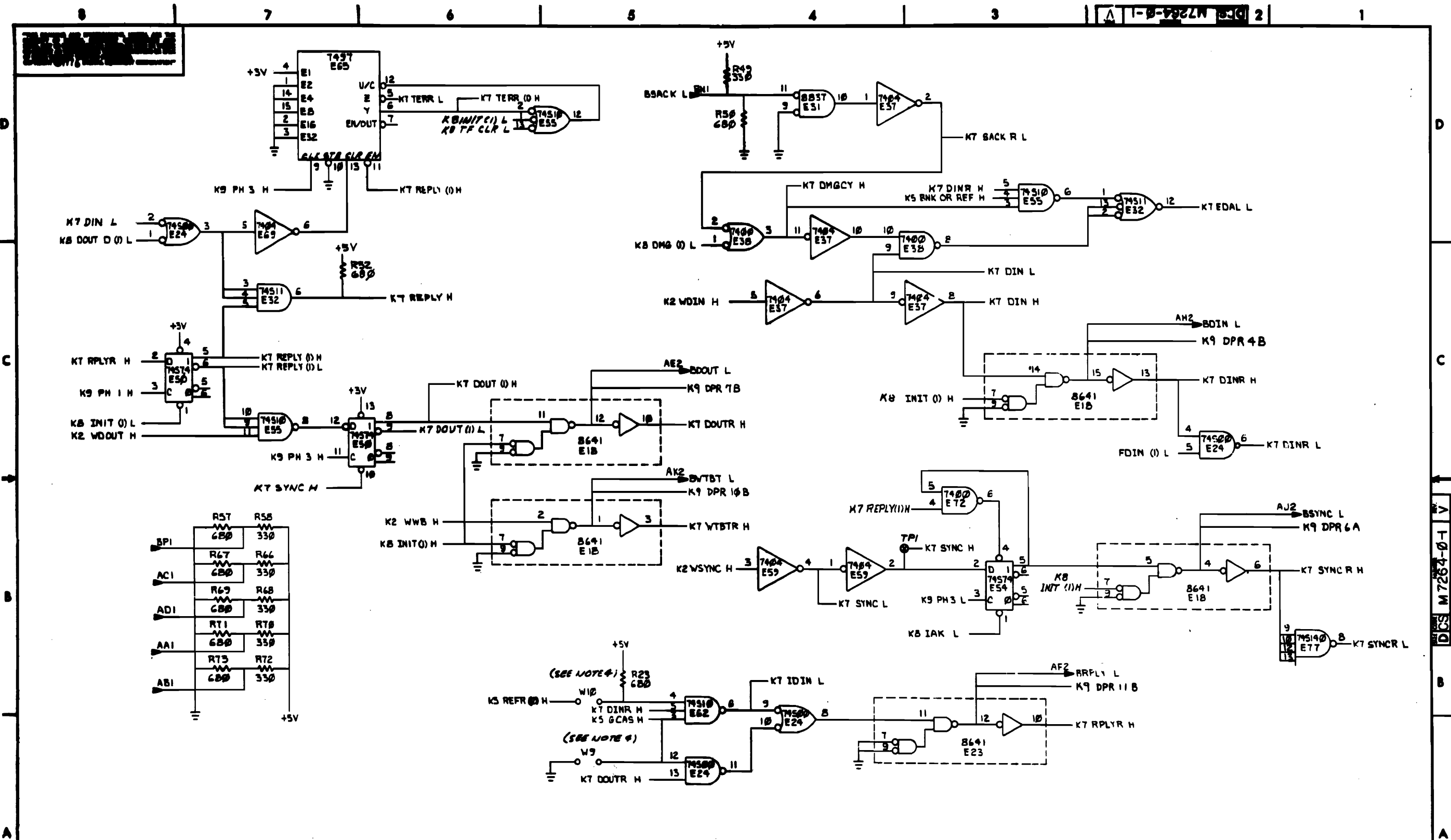

REV.	DATE	CHANGE NO.	BY

THIS SCHEMATIC AND INFORMATIONAL LEVEL ARE THE PROPERTY OF DCS. REPRODUCTION OR DISSEMINATION OF THIS INFORMATION IS PROHIBITED WITHOUT THE WRITTEN PERMISSION OF DCS. © 1977 DCS. ALL RIGHTS RESERVED.

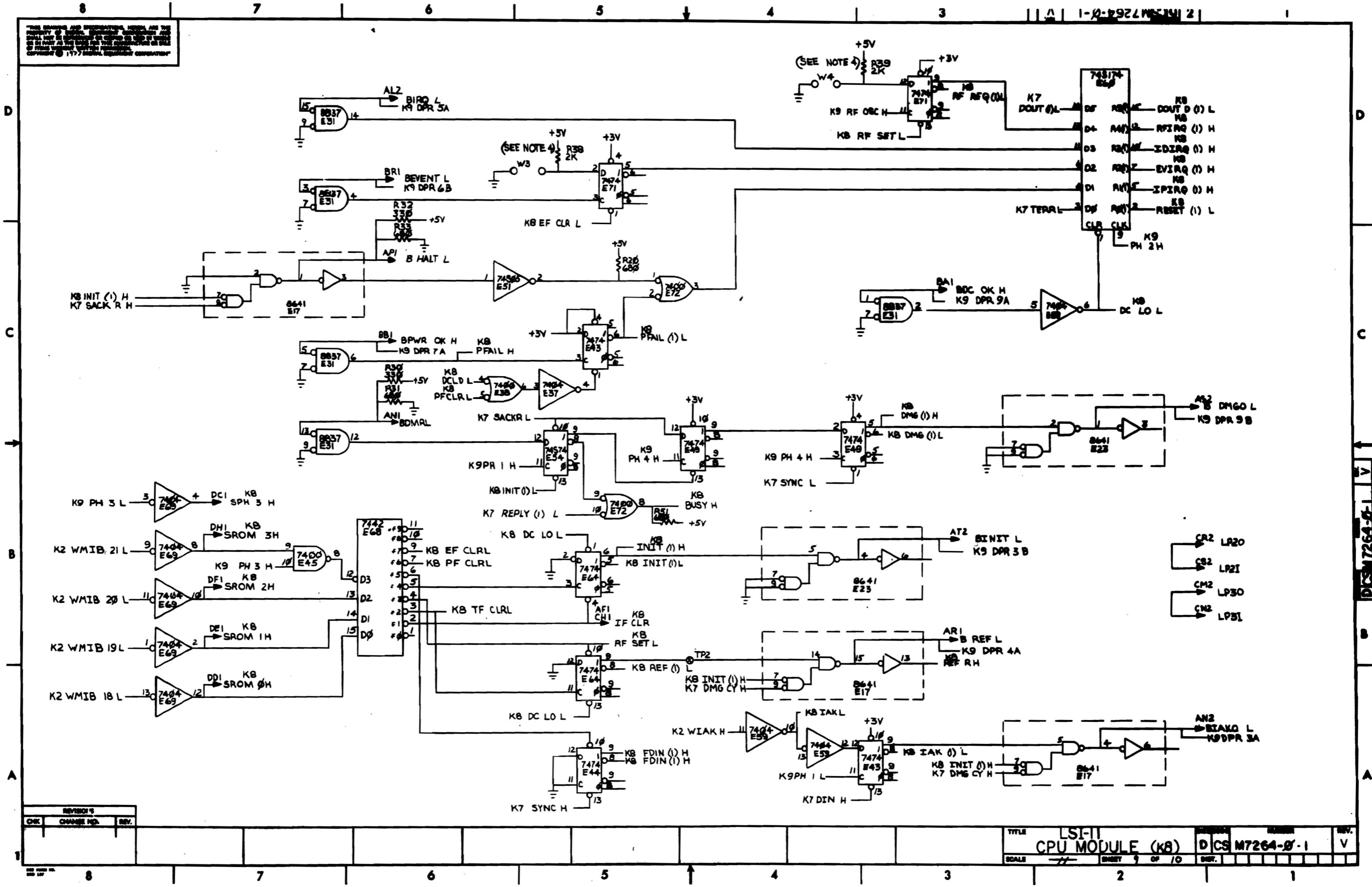

REVISIONS		
CHK	CHANGE NO.	REV.

TITLE	LSI-11	REV.	V
	CPU MODULE (K8)		
SCALE	1/1	SHEET	9 OF 10
		DATE	





DIGITAL EQUIPMENT CORPORATION MAYNARD, MASSACHUSETTS <b>PARTS LIST</b>				QUANTITY/VARIATION																
MADE BY Liz Hevesh DATE 1/19/76		CHECKED R. OLSEN DATE 2-76		SECTION 																
ENG <i>Richard E. Olsen</i> DATE 1/29/76		PROD R. OLSEN DATE 2-6		ISSUED SECT. 																
ITEM NO.	DWG NO. / PART NO.	DESCRIPTION																		
1	MP-0049	CUSTOMER PRINT SET KD11-F		1																
2	DEC11-DVKAA-A-PB	BASIC INSTRUCTION TEST (PAPER TAPE)		*																
3	DEC11-DVKAD-A-PB	TRAP TEST (PAPER TAPE)		*																
4	DEC11-DZKMA-A-PB	MOS/CORE MEMORY TEST (PAPER TAPE)		*																
<del>5</del>	<del>EH-101-11-TM</del>	<del>LSI-11, PDP-11/05 USER'S MANUAL</del>		<del>*</del>																
<del>6</del>	<del>EB-04678-75</del>	<del>LSI-11 PDP-11/05 PROCESSOR HANDBOOK</del>		<del>*</del>																
7	EH-04779-75	LSI-11 PROGRAMMING CARD		*																
8	EB-06583-76	MICROCOMPUTER HANDBOOK		*																
9	DEC11-DVKAA-A-D	BASIC INSTRUCTION TEST DOCUMENT		*																
10	DEC11-DVKAD-A-D	TRAP TEST DOCUMENT		*																
11	DEC11-DZKMA-A-D	MOS/CORE MEMORY TEST DOCUMENT		*																
*NOTE: These items are shipped with first ship to customer.																				
TITLE SHIPPING LIST KD11-F				ASSY NO.		SIZE CODE <b>A PL</b>		NUMBER KD11-F-1				REV. <b>A</b>		ECO NO. KD11-F-00003						
SHEET 1 OF 1				DIST.																